



Specifications

Contact type	Connector type	Backshell	Part number	
			Male insert	Female insert
Crimp contacts supply separately see page 31	Free hanging receptacle	Cable gland (Fig.1)	UTS1JC103P	UTS1JC103S
	Plug	Without (Fig.2)	UTS6103P	UTS6103S
		Cable gland (Fig.3)	UTS6JC103P	UTS6JC103S
PCB contacts supply separately see page 31	Jam nut receptacle	Without (Fig.4)	UTS7103P	UTS7103S



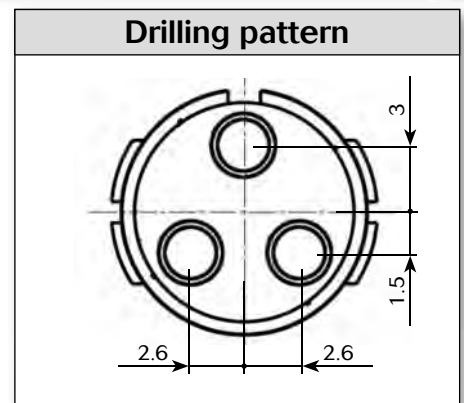
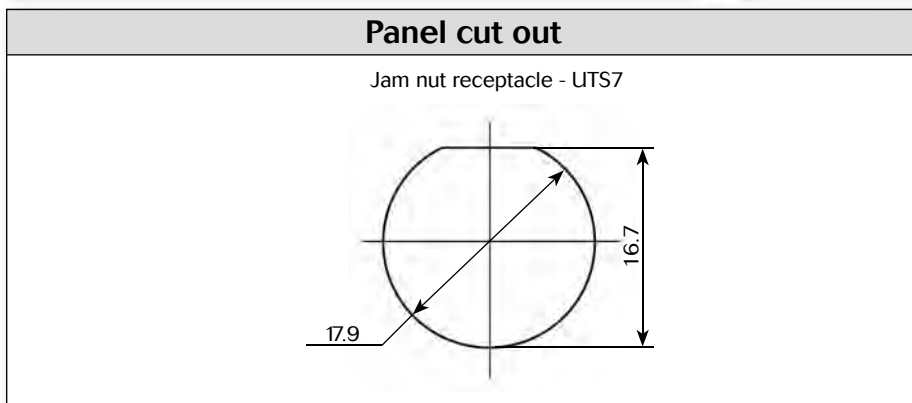
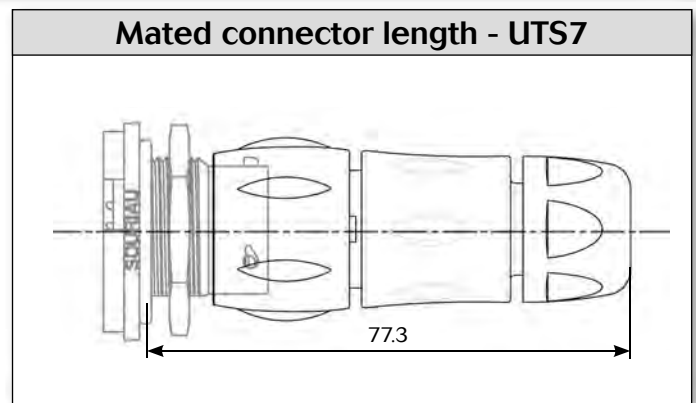
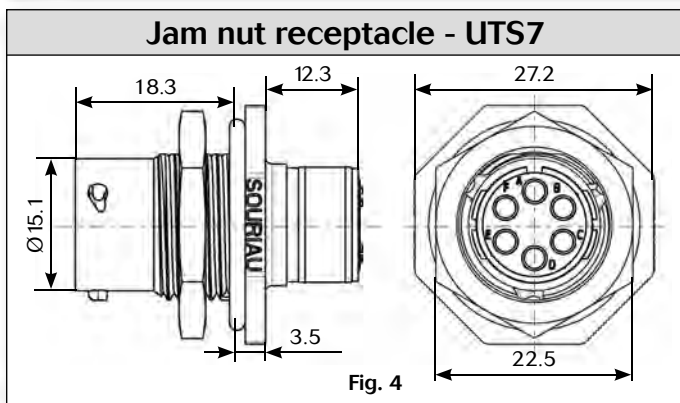
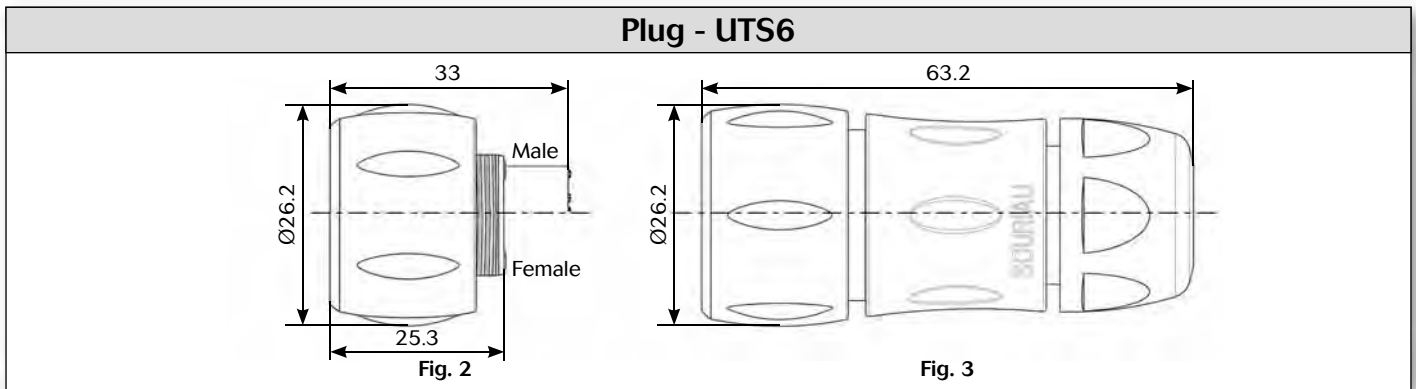
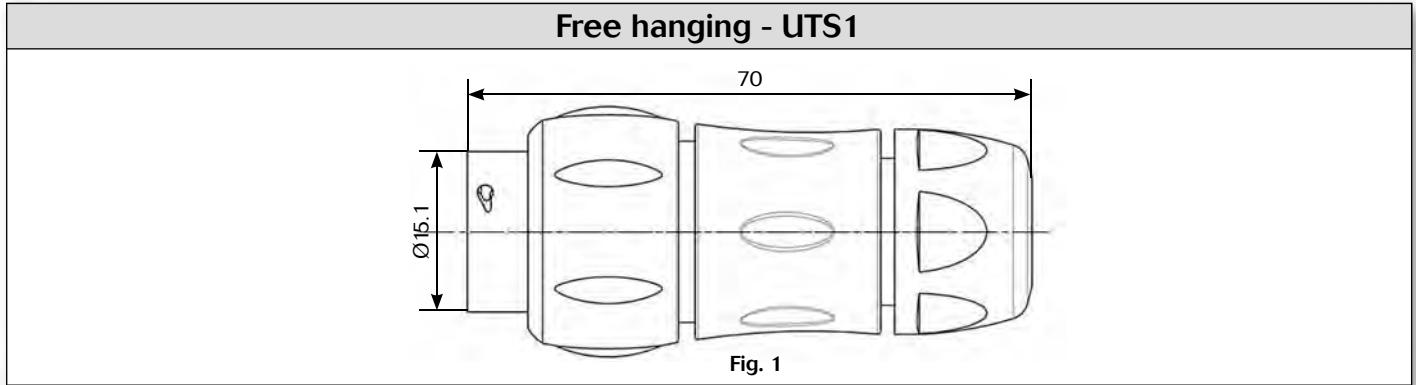

Dimensions



Note: all dimensions are in mm



Accessories and tooling

Jam nut sealing caps	
	
Part number	Part number
UTS10DCG	UTS10DCGR

Metal terminal

Handle

Part number
SHANGLES

Tool kit

Part number
TOOLKIT

Plug sealing cap



Part number
UTS610DCG

Crimp tooling			
			
Contacts	Contact size	Part number of head	
RM/RC 28M1K ⁽¹⁾	Standard contacts #16 Ø 1.6mm	S16RCM20	
RM/RC 24M9K ⁽¹⁾		S16RCM20	
RM/RC 20M13K ⁽¹⁾		S16RCM20	
RM/RC 20M12K ⁽¹⁾		S16RCM20	
RM/RC 16M23K ⁽¹⁾		S16RCM16	
RM/RC 14M50K ⁽¹⁾		S16RCM1450	
RM/RC 14M30K ⁽¹⁾		S16RCM14	
SM/SC 24ML1TK6 ⁽¹⁾		S16SCM20	
SM/SC 20ML1TK6 ⁽¹⁾		S16SCM20	
SM/SC 16ML1TK6 ⁽¹⁾		S16SCML1	
SM/SC 14ML1TK6 ⁽¹⁾		S16SCML1	
SM/SC 16ML11TK6 ⁽¹⁾		S16SCML11	
RMDXK10D28K		Coaxial contacts	M10S-1J
RCDXK1D28K			M10S-1J
RM/RC DX60xxD28K	M10S-1J		
RM/RC DXK10D28 + york090	M10S-1J		
RM/RC DX60xxD28		M10S-1J	

(1): example of plating, for other plating see UTS catalog page 143

Plastic protective cap	
	
Part numbers	
Receptacle cap	Plug cap
85005586A	85005595

Gasket

Part numbers / neoprene
UTFD12B

Color coding rings	
G for Green	
Y for Yellow	
R for Red	
Part numbers	
Receptacles	Plugs
UTS710CCRR	UTS610CCRR
UTS710CCRY	UTS610CCRY
UTS710CCRG	UTS610CCRG

* Add G for Green, Y for Yellow, R for Red



Contacts

#16	Contact type	AWG	Part number		Max wire Ø	Max insulator Ø
			Male	Female		
Crimp	Machined	30-28	RM28M1K ⁽¹⁾	RC28M1K ⁽¹⁾	0.55	1.1
		26-24	RM24M9K ⁽¹⁾	RC24M9K ⁽¹⁾	0.8	1.6
		22-20	RM20M13K ⁽¹⁾	RC20M13K ⁽¹⁾	1.18	1.8
		22-20	RM20M12K ⁽¹⁾	RC20M12K ⁽¹⁾	1.18	2.2
		20-16	RM16M23K ⁽¹⁾	RC16M23K ⁽¹⁾	1.8	3.2
		16-14	RM14M50K ⁽¹⁾	RC14M50K ⁽¹⁾	2.05	3.2
		16-14	RM14M30K ⁽¹⁾	RC14M30K ⁽¹⁾	2.28	3.2
	Stamped & formed reeled contacts	26-24	SM24M1TK6 ⁽¹⁾⁽²⁾	SC24M1TK6 ⁽¹⁾⁽²⁾	0.89-1.28	-
		22-20	SM20M1TK6 ⁽¹⁾⁽²⁾	SC20M1TK6 ⁽¹⁾⁽²⁾	1.17-2.08	-
		18-16	SM16M1TK6 ⁽¹⁾⁽²⁾	SC16M1TK6 ⁽¹⁾⁽²⁾	3.0	-
18-16		SM16M11TK6 ⁽¹⁾⁽²⁾	SC16M11TK6 ⁽¹⁾⁽²⁾	2.0-3.0	-	
14		SM14M1TK6 ⁽¹⁾⁽²⁾	SC14M1TK6 ⁽¹⁾⁽²⁾	3.2	-	
PCB	Machined ⁽³⁾	-	RM20M12E8K ⁽¹⁾	RC20M12E84K ⁽¹⁾	-	-
Coaxial	Cable Multipiece	-	RMDXK10D28	RCDXK1D28	-	-
	Cable Monocrimp	-	RMDX60xxD28	RCDX60xxD28	-	-
	Twisted pair Multipiece	-	RMDXK10D28 + york090	RCDXK1D28 + york090	-	-
	Twisted pair Monocrimp	-	RMDX60xxD28	RCDX60xxD28	-	-
Fiber optic	POF contacts Plastic optical fibre	-	RMPOF1000	RCPOF1000B	-	-

(1): Example of plating, for other plating see page 143
 (2): Loose piece contact available if putting L. Example: SM20ML1-TK6
 (3): For dimensions see page 148

Electrical characteristics
<p>UL 10A 500V UL94 V-0</p> <p>CSA 7A 500V UL94 V-0</p> <p>IEC 16A 300V 4kV 3 Temperature elevation: 50°C</p>

