



A-MP* EXTRACTION TOOL
 CATALOG NO. 465644
 FOR A-MP MATE-N-LOK* CONTACTS

IS 7211	
RELEASED	2-24-65
REVISED	

AUTOMATIC MACHINE DIVISION

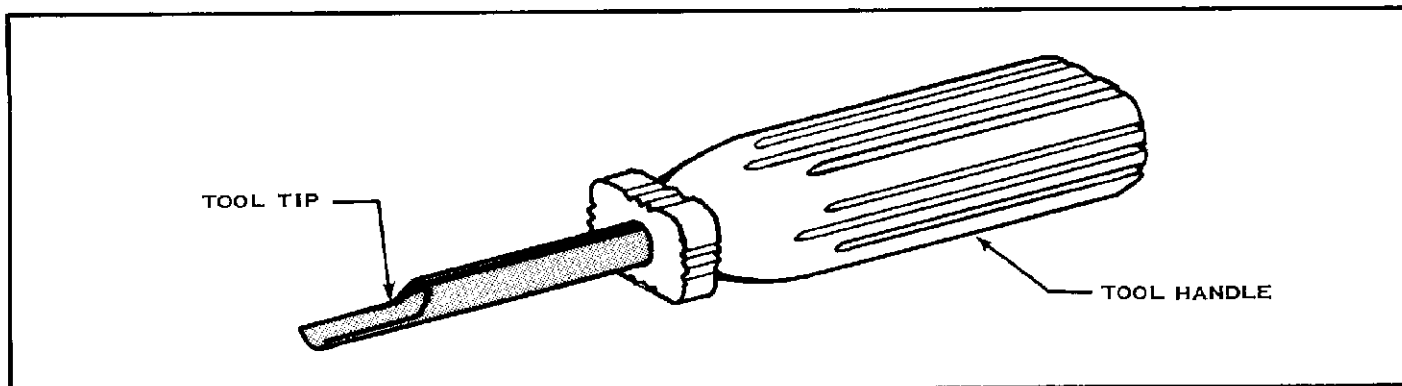

Fig. 1

1. This Tool is used to remove A-MP MATE-N-LOK Contacts from their Housings. See Figure 1. Read these instructions carefully before using the Tool.

2. EXTRACTION PROCEDURE — SOCKET

- (a) View Plug as shown in Figure 2. Notice seam on Socket Contact.
- (b) Push Socket forward in Cavity as far as it will go and insert Tool Tip into Contact Cavity (see Figure 2) so that Tip is on opposite side of Contact from seam.
- (c) Make sure Tool is completely bottomed in Cavity. Then pull on Wire to remove Contact from Cavity. See Figure 2.

3. EXTRACTION PROCEDURE — PIN

- (a) Place Tool Tip against Locking Lance on Pin Contact as shown in Figure 3.
 - (b) Use Tool Tip to depress Locking Lance enough to remove Contact from Housing. Then pull on Wire to remove Contact from Cavity. See Figure 3.
- NOTE: Before using Contact again, reset Locking Lance to its original position.

*Trademark of AMP Incorporated

© 1965 by AMP Incorporated. All international rights reserved. AMP products covered by U.S. and foreign patents and/or patents pending.

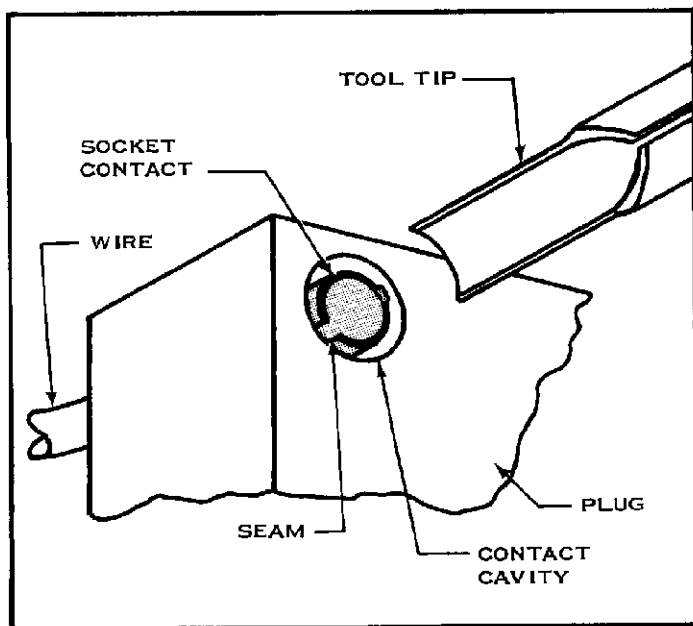

Fig. 2

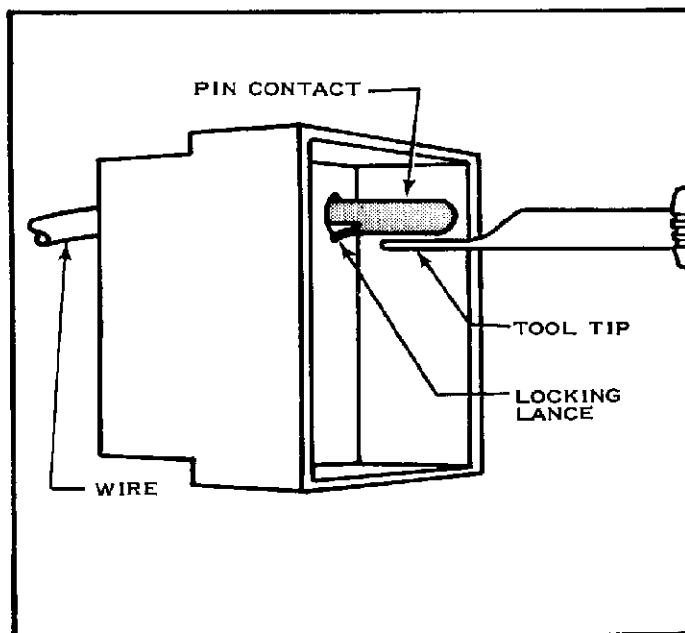

Fig. 3