

Kurzhubzylinder ND/NE

Kurzhubzylinder, doppeltwirkend mit verdrehgesicherter Kolbenstange **ND**

Werkstoffe: Kopf- und Fußplatte: Aluminium eloxiert / Messing, Zylinderrohr: Aluminium eloxiert, Kolbenstange: 1.4305, Dichtung: NBR
Temperaturbereich: -20°C bis max. +80°C
Betriebsdruck: max. 10 bar
Ausführung: mit Magnetkolben



Zylinder-schaltertyp



ab Seite 888

Kolben Ø 20 mm	Kolben Ø 25 mm	Kolben Ø 32 mm	Kolben Ø 40 mm	Kolben Ø 50 mm	Hub
NDM 20/5 A	NDM 25/5 A	---	---	---	5
NDM 20/10 A	NDM 25/10 A	NDM 32/10 A	NDM 40/10 A	NDM 50/10 A	10
NDM 20/20 A	NDM 25/20 A	NDM 32/20 A	NDM 40/20 A	NDM 50/20 A	20
NDM 20/25 A	NDM 25/25 A	NDM 32/25 A	NDM 40/25 A	NDM 50/25 A	25
NDM 20/40 A	NDM 25/40 A	NDM 32/40 A	NDM 40/40 A	NDM 50/40 A	40
NDM 20/50 A	NDM 25/50 A	NDM 32/50 A	NDM 40/50 A	NDM 50/50 A	50
---	---	NDM 32/80 A	NDM 40/80 A	NDM 50/80 A	80

Kolben Ø 63 mm	Kolben Ø 80 mm	Kolben Ø 100 mm	Hub
NDM 63/10 A	NDM 80/10 A	NDM 100/10 A	10
NDM 63/20 A	NDM 80/20 A	NDM 100/20 A	20
NDM 63/25 A	NDM 80/25 A	NDM 100/25 A	25
NDM 63/40 A	NDM 80/40 A	NDM 100/40 A	40
NDM 63/50 A	NDM 80/50 A	NDM 100/50 A	50
NDM 63/80 A	NDM 80/80 A	NDM 100/80 A	80

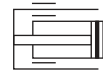

Maße finden Sie auf Seite 866.

Gabelköpfe (Außengewinde) mit Bolzen

für Kurzhubzylinder ND/NE

Typ	A	B	C	D	E	F	G	H	GL	für Kolben Ø
Stahl verzinkt										
GAKA M6	M 6	12	37	17	6	44	12	6	15	32 & 40
GAKA M8	M 8	16	47	22	8	57	16	8	20	50 & 63
GAKA M10	M 10	20	57	27	10	69	20	10	25	80
GAKA M12	M 12	24	68	33	12	82	24	12	30	100

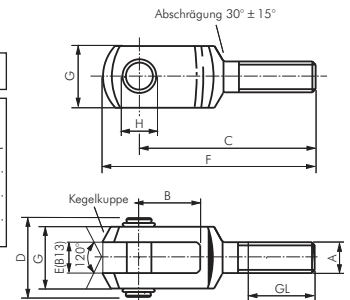

Gelenkköpfe (Außengewinde)

für Kurzhubzylinder ND/NE

Werkstoffe: Typ Stahl verzinkt: Gehäuse: Stahl verzinkt, Lagerung: Messing/PTFE, Innenring: 100Cr6
 Typ Edelstahl: Gehäuse: 1.4301, Lagerung: 1.4301/PTFE, Innenring: 1.4021

Typ	Typ	A	B	C	D	D2	H	L	GL	für Kolben Ø
Stahl verzinkt	Edelstahl									
SGSA M4	---	M 4	7	5,25	4	14	30	37	19	16
SGSA M5	SGSA M5 ES	M 5	8	6,0	5	18	33	42	19	20 & 25
SGSA M6	SGSA M6 ES	M 6	9	6,75	6	20	36	46	21	32 & 40
SGSA M8	SGSA M8 ES	M 8	12	9,0	8	24	42	54	25	50 & 63
SGSA M10	SGSA M10 ES	M 10	14	10,5	10	28	48	62	28	80
SGSA M12	SGSA M12 ES	M 12	16	12,0	12	32	54	70	32	100

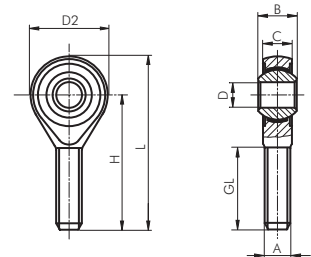

Kompaktschlitzen mit Führung ab Seite 873



Steckanschlüsse Ø 3 - 32 mm ab Seite 46



PU-, PA-, PTFE- und PE-Schläuche ab Seite 368



Magnetventile Airtac ab Seite 750

Alle Angaben verstehen sich als unverbindliche Richtwerte! Für nicht schriftlich bestätigte Datenauswahl übernehmen wir keine Haftung. Druckangaben beziehen sich, soweit nicht anders angegeben, auf Flüssigkeiten der Gruppe II bei +20°C.

Kurzhubzylinder ND/NE

Hauptabmessungen - Kurzhubzylinder

ND/NE

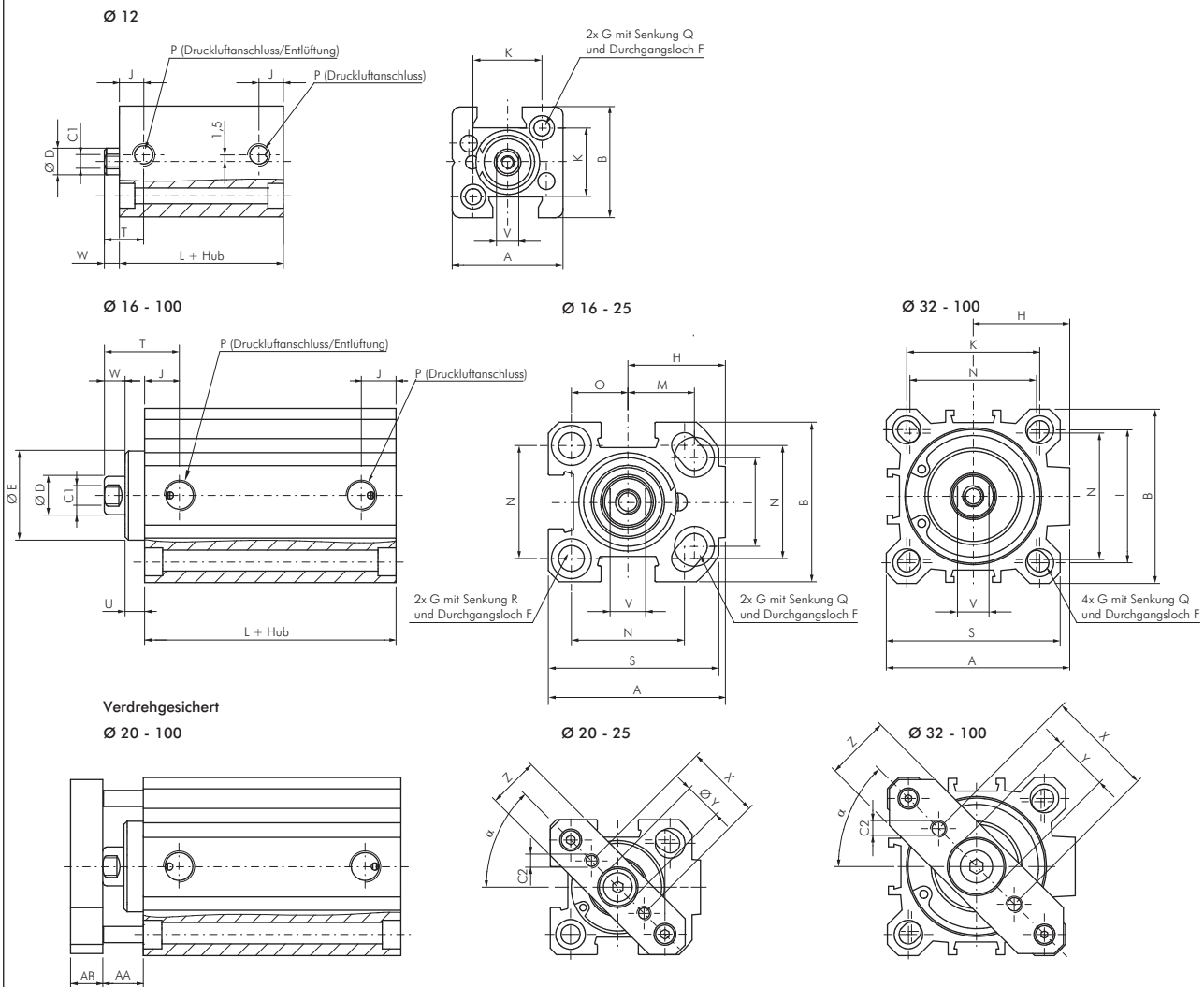

Kolben Ø	A	B	C1	C2	D	E ⁶⁾	F	Ø G	H	I	J	K	L NE/ND	L NDM/NEM/NDM ... A	M	
12 mm	25,0	25	M 3	---	6	---	3,7	5,6	---	---	5,5	15,5	17,0	27,0	---	
16 mm	34,0	30	M 4	---	8	---	4,7	7,5	19,0	18	8,0	---	27,0 (28,0) ¹⁾	32,0 (38) ⁴⁾	12,0	
20 mm	40,0	36	M 5	M 4	10	---	5,8	9,0	22,0	20	8,0	---	27,0 (28,0) ¹⁾	32,0 (38) ⁴⁾	15,0	
25 mm	44,5	40	M 5	M 4	10	---	5,8	9,0	24,5	26	10,5	---	28,5 (29,5) ²⁾	38,5 (39,5) ⁴⁾	15,5	
32 mm	51,0	46	M 6	M 5	12	24,5	5,8	9,0	27,0	32	11,5	36,0	29,5 (39,5) ³⁾	39,5 (49,5) ³⁾	---	
40 mm	58,0	55	M 6	M 5	12	28,0	5,8	9,0	30,5	42	11,0	42,0	29,5 (39,5) ³⁾	39,5 (49,5) ³⁾	---	
50 mm	70,0	65	M 8	M 6	16	34,0	6,8	11,0	37,5	50	11,5	50,0	34,5 (44,5) ³⁾	39,5 (49,5) ³⁾	---	
63 mm	86,0	80	M 8	M 6	16	38,5	9,0	14,0	46,0	62	11,0	62,0	37,0 (47,0) ³⁾	42,0 (52) ³⁾	---	
80 mm	105,0	100	M 10	M 8	20	44,0	9,0	14,0	55,0	82	14,0	82,0	46,0 (56,0) ³⁾	46,0 (56) ³⁾	---	
100 mm	131,0	124	M 12	M 10	25	56,0	11,0	17,2	69,0	103	16,0	103,0	56,0 (66,0) ³⁾	56,0 (66) ³⁾	---	
Kolben Ø	N	O	P	Q	R	S	T	U ⁶⁾	V	W	X	Y	Z	AA	AB	α
12 mm	---	---	M 5	3,5	---	---	6	---	5	3,5	---	---	---	---	---	---
16 mm	20,0	10,0	M 5	4,6	3,5	32,0	8	---	6	4,5	---	---	---	---	---	---
20 mm	25,5	12,7	M 5	5,7	5,7	38,5	10	---	8	5 (4,5) ⁵⁾	20	11	15	4,5	8	45°
25 mm	28,0	14,0	G 1/8"	5,7	5,7	42,0	10	---	8	5,5	22	11	15	5,5	8	45°
32 mm	34,0	---	G 1/8"	5,7	---	48,0	12	5,0	10	6 (5,5) ⁵⁾	28	17	20	11,0	10	41,5°
40 mm	40,0	---	G 1/8"	5,7	---	55,0	12	6,0	10	6 (6,5) ⁵⁾	33	17	20	12,5	10	45°
50 mm	50,0	---	G 1/8"	6,8	---	65,0	12	6,0	13	7,5	42	22	30	13,5	12	45°
63 mm	60,0	---	G 1/8"	8,8	---	80,0	14	8,0	13	7 (6,5) ⁵⁾	50	22	30	15,0	12	45°
80 mm	77,0	---	G 1/4"	9,0	---	100,0	15	10,0	17	8	65	28	50	18,0	14	45°
100 mm	94,0	---	G 1/4"	11,0	---	124,0	20	10,5	22	10	80	30	50	20,5	14	45°

1) Typ ND: für Hub 30 - 50 mm, 2) Typ ND: für Hub 40 - 50 mm, 3) Typ NE/NEM: für Hub 40 - 50 mm, 4) für Hub ≥ 25 mm, 5) Typ NEM/NDM, 6) Typ NDM/NDM ... A