

DASH NO.	M CODE	MADE FROM
----------	--------	-----------

# GSD

1705-1

REVISIONS	
ISSUE	CHANGES
6	CN 32731 C REDRAWN KH 12/10/90
7	CN 35381 E MJB 03/30/94
8	CN 37799 E TML 03/09/99
9	CN 39699 C DCT 11/14/6

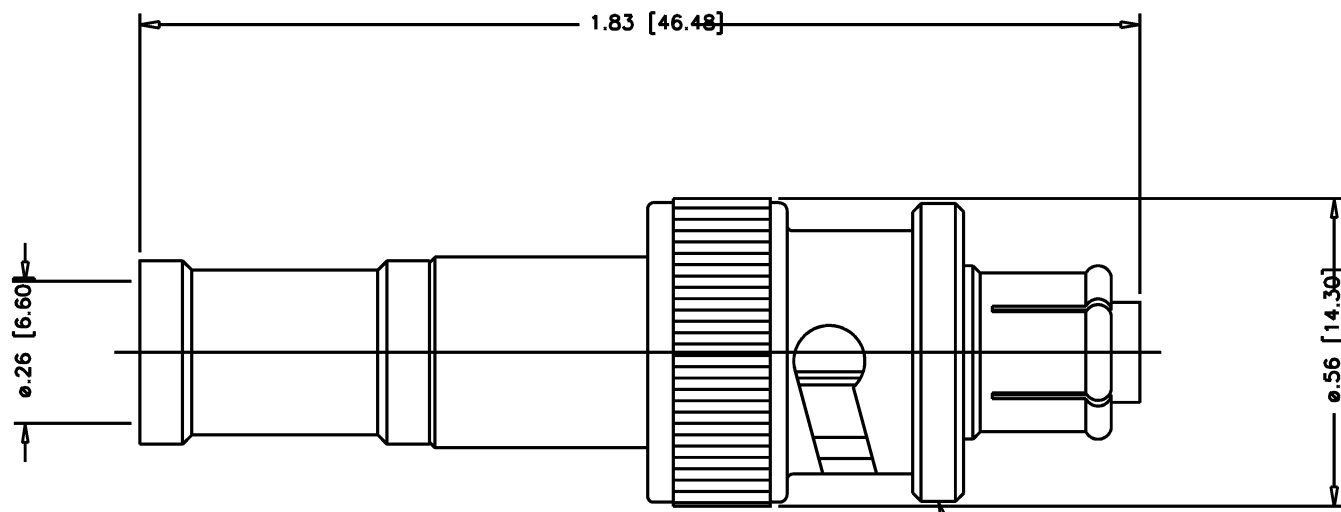

STAMP: KINGS 1705-1  
YRWK (DATE CODE)

- NOTES:
- FOR USE WITH RG-59, 62 & 210/U CABLE.
  - FOR CABLING INSTRUCTIONS SEE CP-441.
  - FOR CABLE TRIMMING USE KTJ-72 & KTD-134.
  - FOR CRIMPING USE DIE KTH-2062.
  - MATERIALS:  
INSULATOR: TEFLON, ASTM-D-D4894  
GASKET: SIL. RUB., A-A-59588  
K-GRIP SLEEVE: COMMERCIAL BRONZE TUBE, ASTM-B135  
SPRING WASHER & CONTACTS: BER. COP., ASTM-B-196  
ALL OTHER PARTS: BRASS, ASTM-B16
  - FINISHES:  
CENTER CONTACT: HARD GOLD PLT. PER ASTM-B488  
ALL OTHER METAL PARTS: KINGS TARNISH RESISTANT FINISH (TR-5)
  - ELECTRICAL CHARACTERISTICS:  
OPERATING VOLTAGE: 3500 VOLTS AC  
5000 VOLTS DC
  - DIMENSIONS IN INCHES [MM].

SCALE 4:1	
APPROX SURFACE AREA	
USED ON	
REF: N.B.S. ND-545C	
PLUG, SHV	
DRAWN JCA	DATE 12/10/90
DESIGN LJ	DATE 12/11/90
APPR.	DATE

**KINGS**  
ELECTRONICS CO., INC.  
ROCK HILL, SOUTH CAROLINA 29730

# GSD

1705-1