

# Ender-5 Plus Printer

To be the Chief Evangelist

# Guide Book

To make Top-quality 3D printer

- ◆ This guide book is for standard Ender-5 Plus only.
- ◆ Please plug the power cord into a three-hole power jack.
- ◆ Detailed instructions are available in the TF card.

# WARNING

1. Do not use the printer any way other than described herein in order to avoid personal injury or property damage.
2. Do not place the printer near any heat source or flammable or explosive objects. We suggest placing it in a well-ventilated, low-dust environment.
3. Please place your printer under a stable environment in order to achieve high print quality.
4. Before using experimental or exotic filaments, we suggest using standard filaments such as ABS or PLA to calibrate and test the machine.
5. Do not use any other power cable except the one supplied. For your safety, you must use a grounded three-prong power outlet.
6. Do not touch the nozzle or printing surface during operation as they may be hot. Keep hands away from machine while in use to avoid burns or other personal injuries.
7. Do not wear gloves or loose clothing when operating the printer. Such cloths may become tangled in the printers moving parts leading to printer damage, burns, or personal injuries.
8. When cleaning debris from the printer hot end, please use the provided tools. Do not touch the nozzle when heated. This maybe cause personal injury.
9. Clean the printer frequently. Always turn the power off when cleaning, and wipe with a dry cloth to remove dust, adhered printing plastics or any other material off the frame, guide rails, or wheels . Use glass cleaner or isopropyl alcohol to clean the print surface before every print for consistent results.
10. Children under 10 years of age should not use the printer without supervision.

# Contents

1.Introduction.....	1	6.Loading Filament.....	9
2.General List.....	2	7.Bed Leveling.....	10
3.Assembly Step.....	3	8.Software Installation.....	12
4.Cable Connection.....	7	9.Preparing to Print.....	13
5.Screen Information.....	8	10.Circuit Wiring.....	14

## Preface

### Dear consumers,

Thank you for choosing our products. For your best experience, please read the instructions before operating the Printer. Our 3D team will always be ready to provide you the best service. Please contact us via the phone number or e-mail address provided on the last page of the instruction when you encounter any issue with the Printer.

For a better experience in using our product, you may learn how to use the Printer in the following ways:

1. View the accompanied instructions and videos in the TF card.
2. Visit our official website [www.creality3d.cn](http://www.creality3d.cn) You will find relevant software/hardware information, contact details and operation and maintenance instructions on the website.

## Introduction :

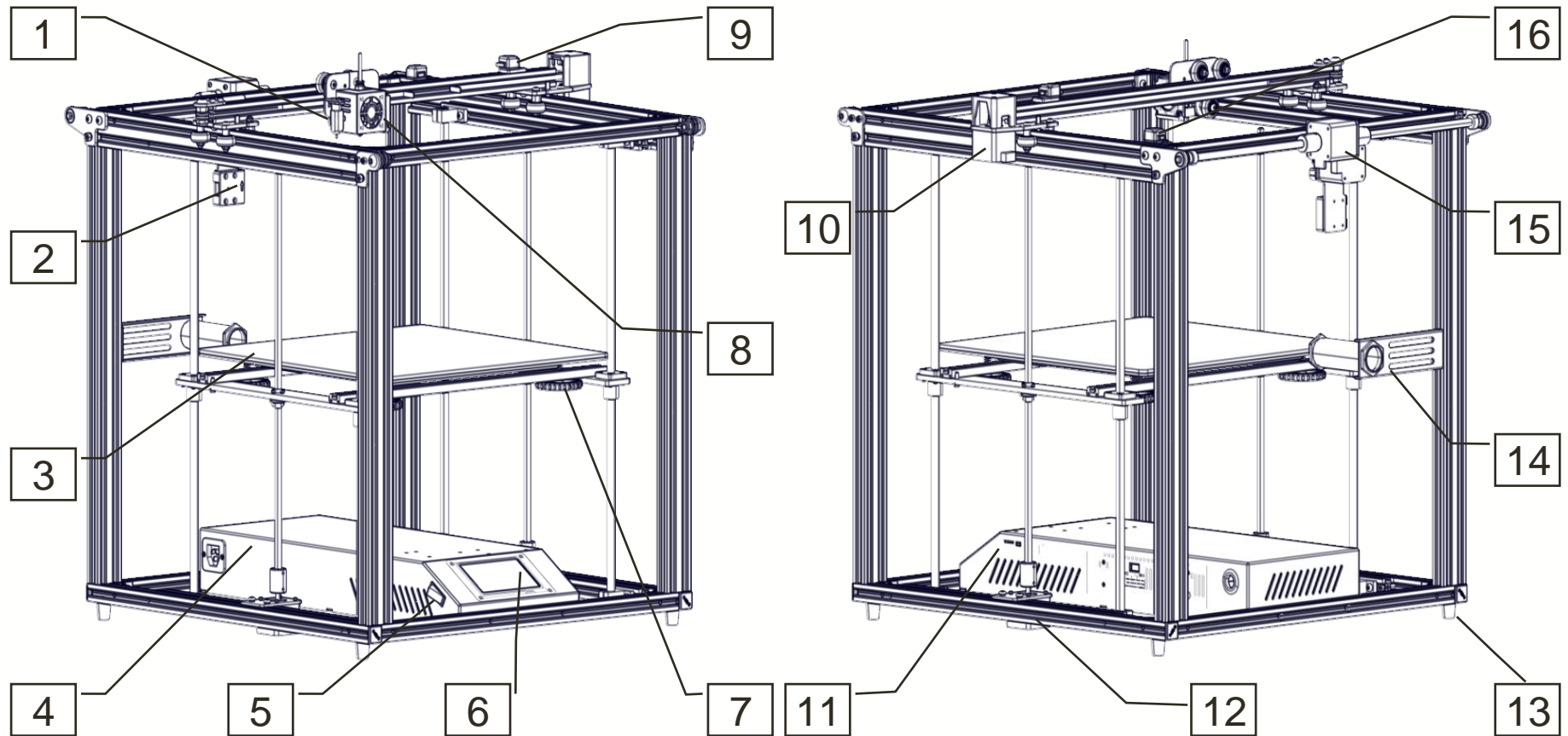

- 1. BL Touch
- 2. broken filament detecting device
- 3. Hot Bed
- 4. Main control box

- 5. Power switch
- 6. Touch screen
- 7. Leveling nut
- 8. Hot end

- 9. X-axis limit switch
- 10. X-axis motor
- 11. TF card & USB
- 12. Z-axis motor

- 13. Antivibration feet
- 14. Filament Holder
- 15. Y-axis motor
- 16. Y-axis limit switch

## General List :

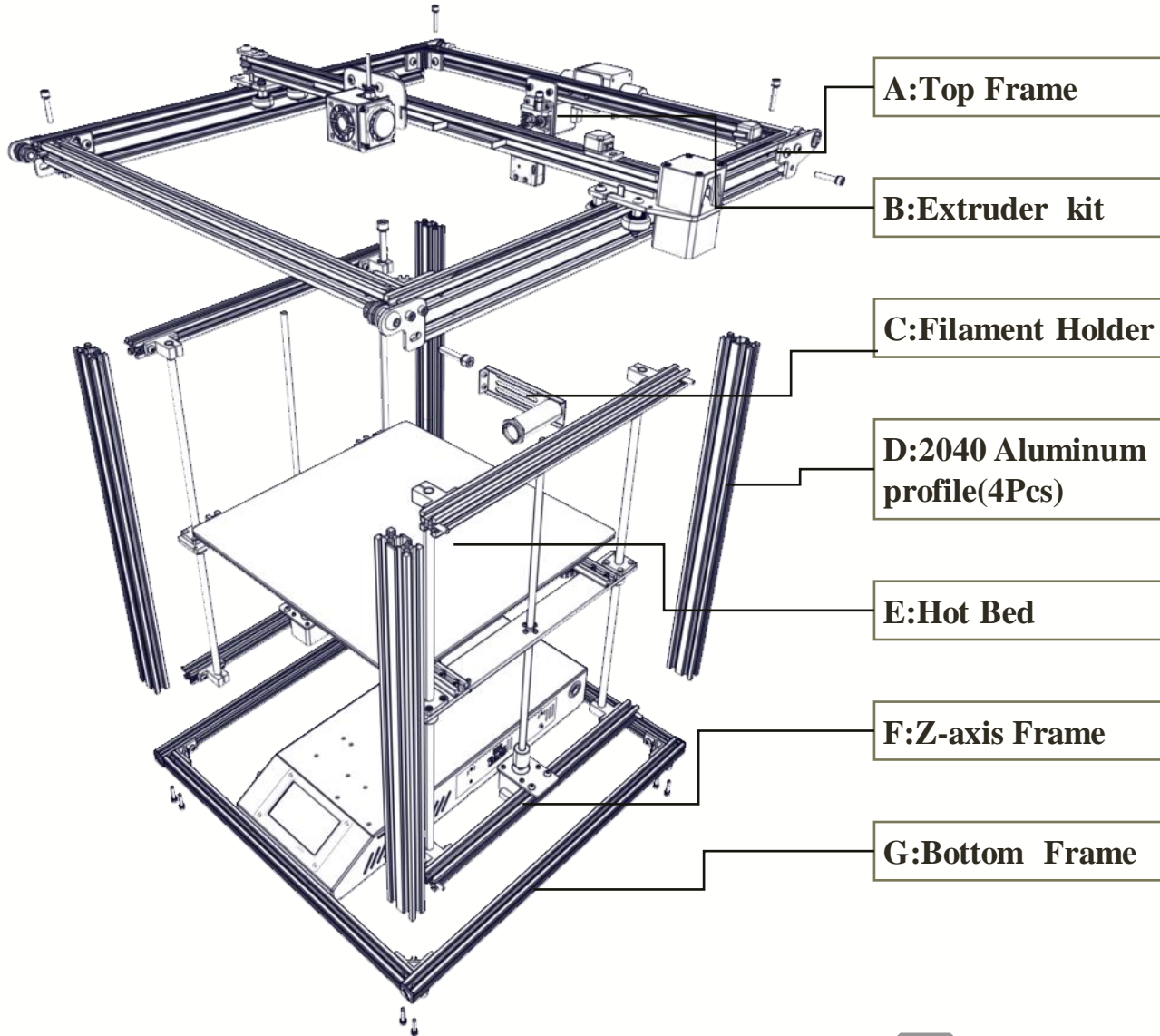

## Tool List

No.	Image	Name	Qty
1		Wrench & Screw driver	1set
2		TF Card & Reader	1set
3		Spatula	1
4		Pliers	1
5		0.4mm Nozzle Cleaner	1
6		Power Cable	1
7		Filament(200g)	1
8		Spare Parts	1set
9		USB	1

## Frame Assembly Pt. 1

Ready:

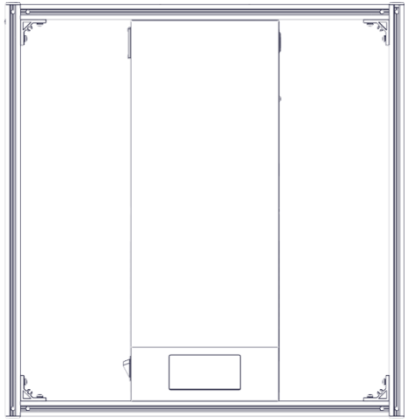

2040 Aluminum  
profile(4Pcs)

Bottom Frame



M5X25

8pcs

**i Note:** Please note that the hole at the top of piece facing left and right, in relation to the front of the printer.

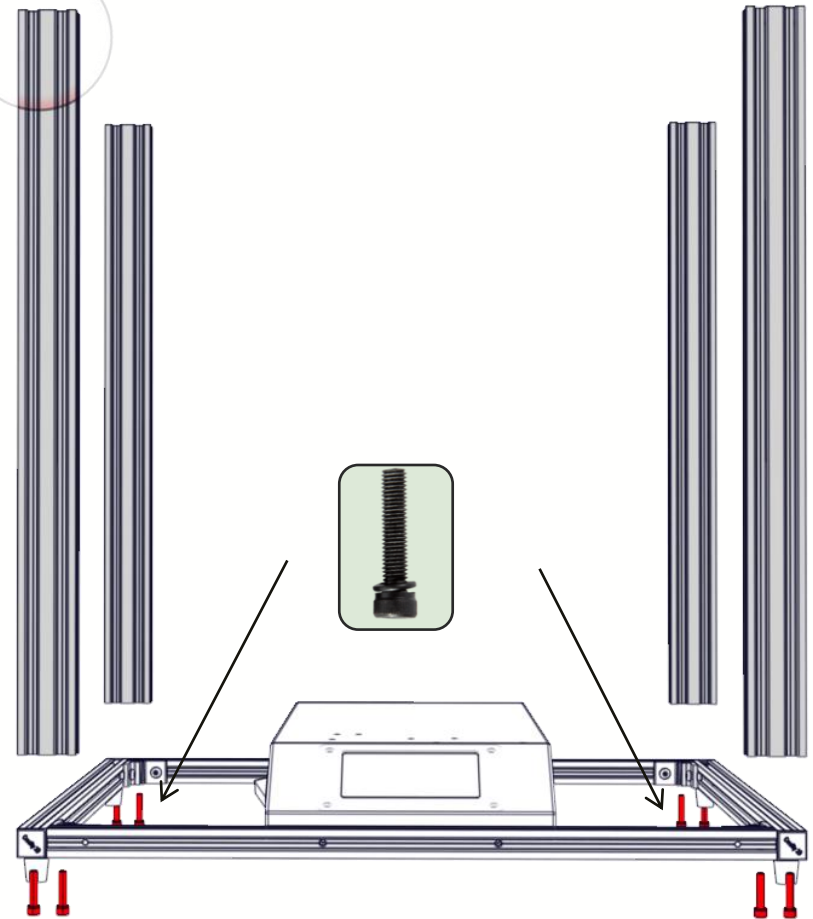

**Step 1.** Keep the front of the Bottom Frame facing you.

**Step 2.** Take one of the Aluminum frame pieces and place it in the corner of the bottom frame, On top of the frame, and lined up with the corner. Notice the hole at the top of piece facing left and right, in relation to the front of the printer. Use 2 M5x25 screws and washers to secure part to the bottom frame.

**Step 3.** Install the remaining 2 aluminum profile in the same way as Step 3.

## Frame Assembly Pt. 2

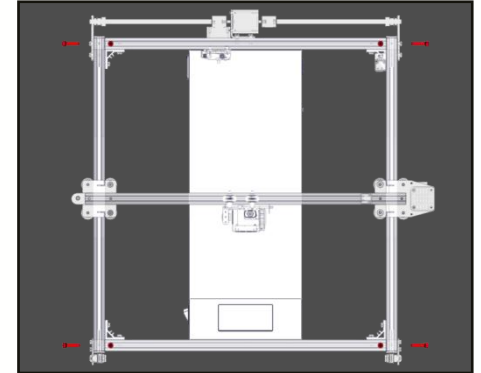
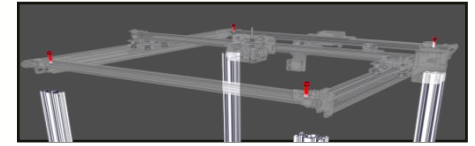
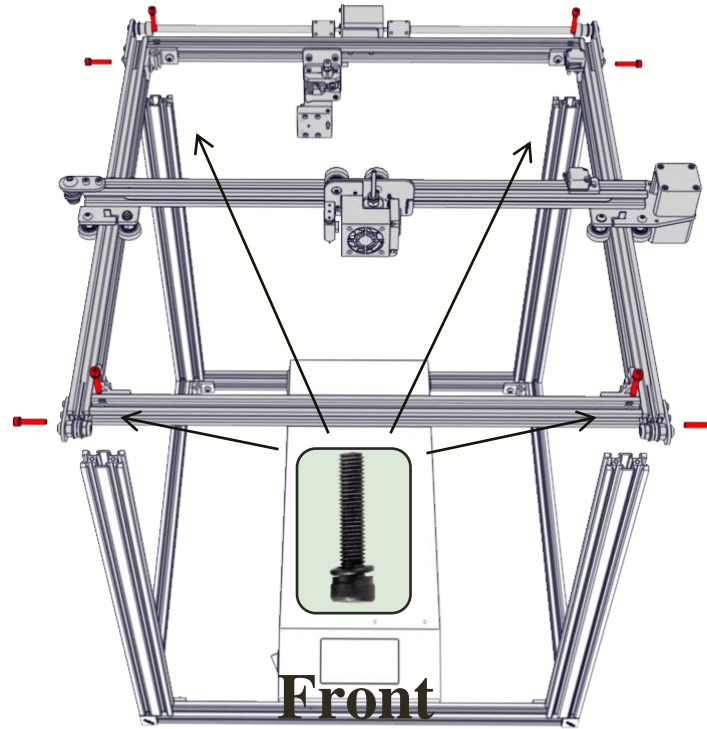
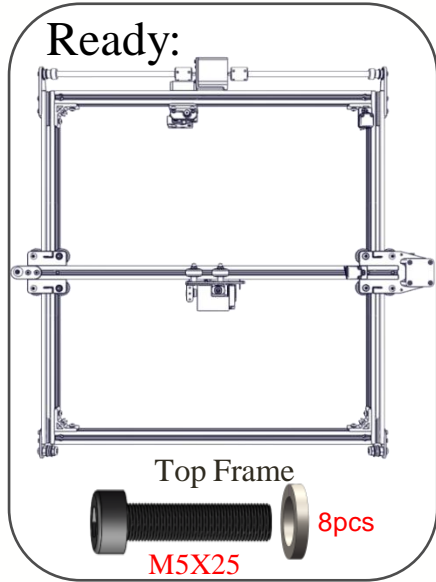

**Note:**

1. Tighten the four screws on the top, then tight the side screws.
2. Facing your top-side Y-axis passive block, you can adjust it to adjust the timing belt tightness.

**Step 1.** Make sure the front of the bottom frame is facing you .

- Step 2.**
- 1) Place the Top frame on top of all four aluminum frames.
  - 2) Line up the pre-drilled screw holes on tops of aluminum frame with the holes on top of Top frame and tighten in place with an M5x25 screw and washer at each corner.
  - 3) After 4 screws on top are tightened, use 4 M5x25 screws and washers to fasten corner brackets in each corner of Top frames, into corresponding holes on outside edge of aluminum frame

## Frame Assembly Pt. 3

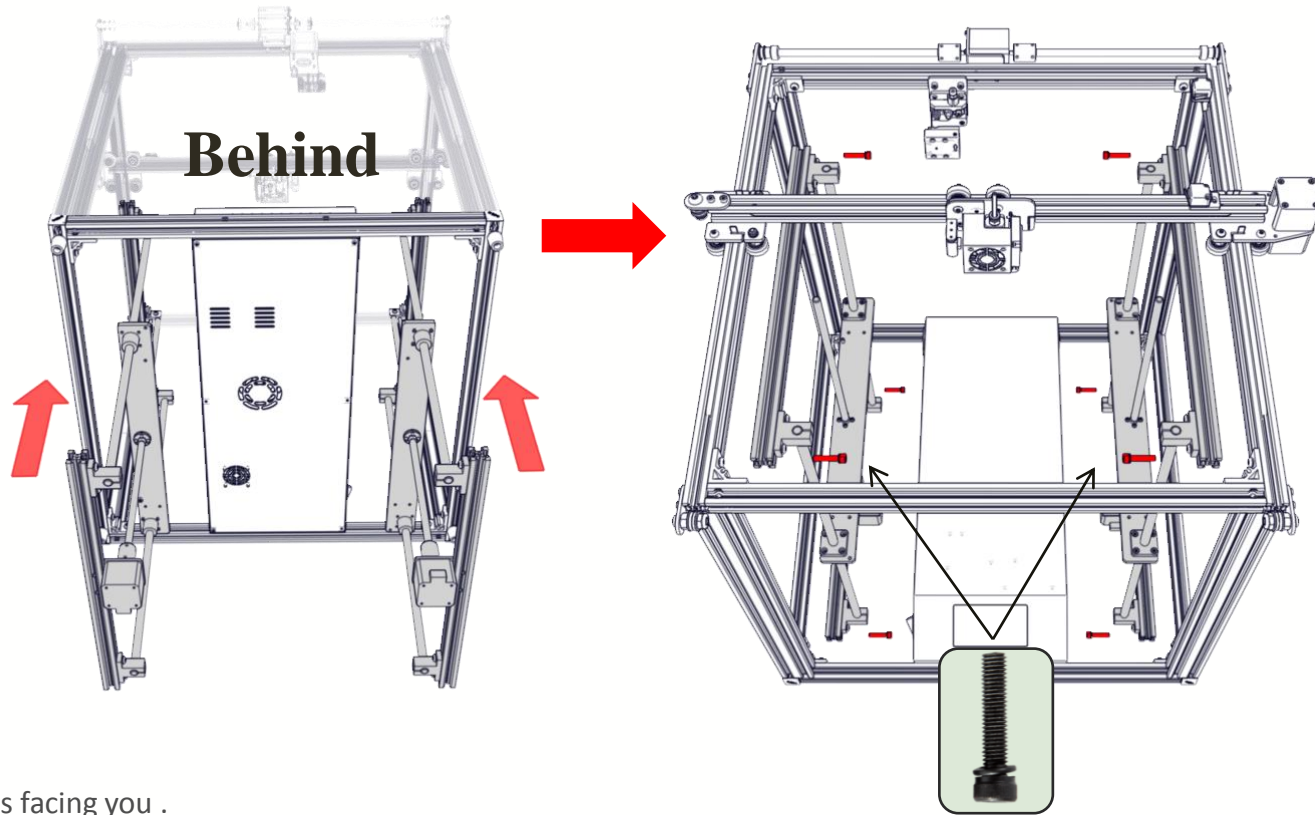
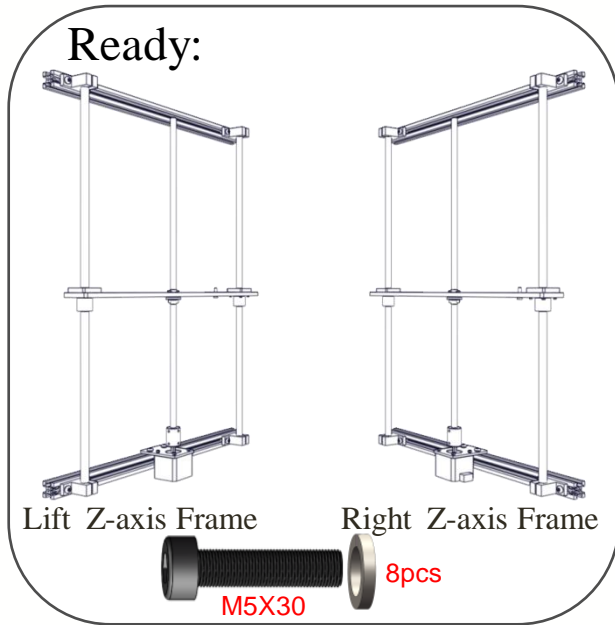

**Step 1.** Make sure the front of the bottom frame is facing you .

**Step 2.** Place double Z-axis frame inside of previously assembled frame. The double Z-axis frame is mounted on the left and right 2040 aluminum profiles of the top frame and must be aligned with the aluminum profile. Making sure the motor is on the bottom, attach the frame to the lower and upper assembly with a M5x30 screw and washer at each corner. The upper and lower assembly extrusions will have corresponding pre-drilled holes for these screws.

**Step 3.** After the installation of the double Z-axis frame is completed, please check if your Y-axis can move smoothly. If the movement is hindered and the aluminum profile is rubbed, please adjust the eccentric nut and reassemble your Z-axis frame.

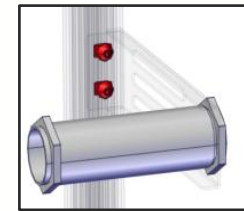
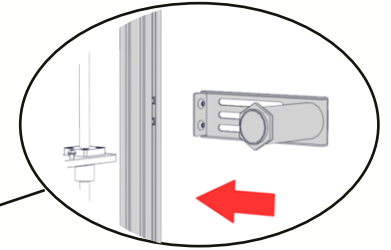
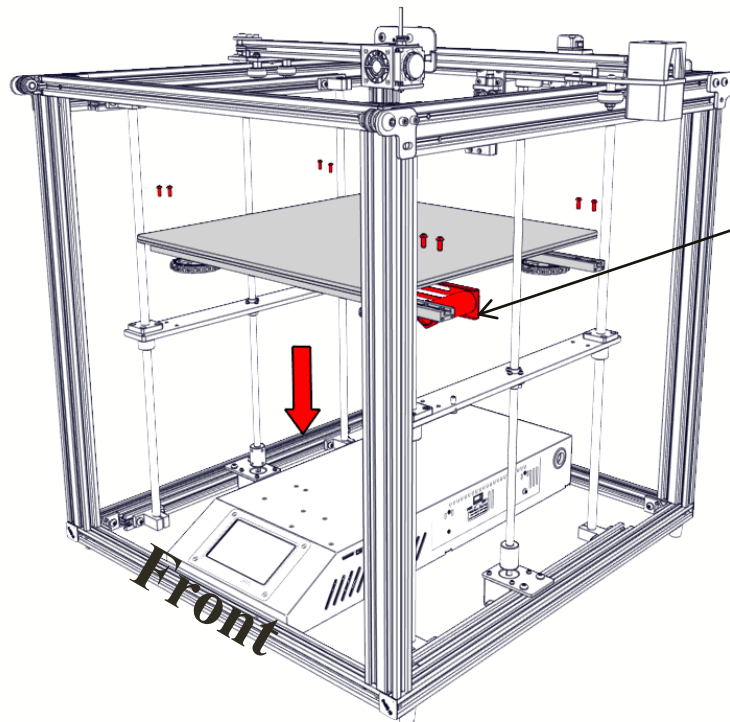
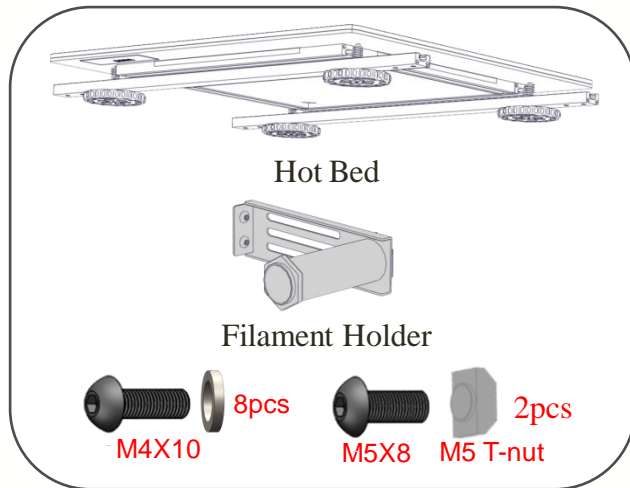

**Frame Assembly Pt. 4**

- Step 1.** Make sure the front of the base(b) is facing you. Place the hot bed on the support plate of the double Z-axis frame and align with the profile holes on it.
- Step 2.** Using 4 M4x10 screws, connect the hot bed to the support plate on the Z-axis frame. Make sure the hot bed is flat and all six screws are securely fastened.
- Step 3.** Subsequently, pass the M5x8 socket head cap screw through the threaded hole on the of the metal plate filament bracket , then pass the M5 T-nut and gently turn the M5 T-nut. Do not tighten. Rotate the M5 T-nut that has been installed on the metal plate filament bracket into a position parallel to the groove of the aluminum profile, and insert it into the aluminum profile. The M5 T-nut below the metal plate filament bracket is parallel to the groove of the 2040 aluminum profile and is inserted into it. The upper M5 T-nut on the metal plate filament bracket is parallel to the 2040 aluminum profile and inlaid, then tighten the screw with an Allen key and tighten the M5 T-nut to a position perpendicular to the groove of the aluminum profile.

## Cable Connection :

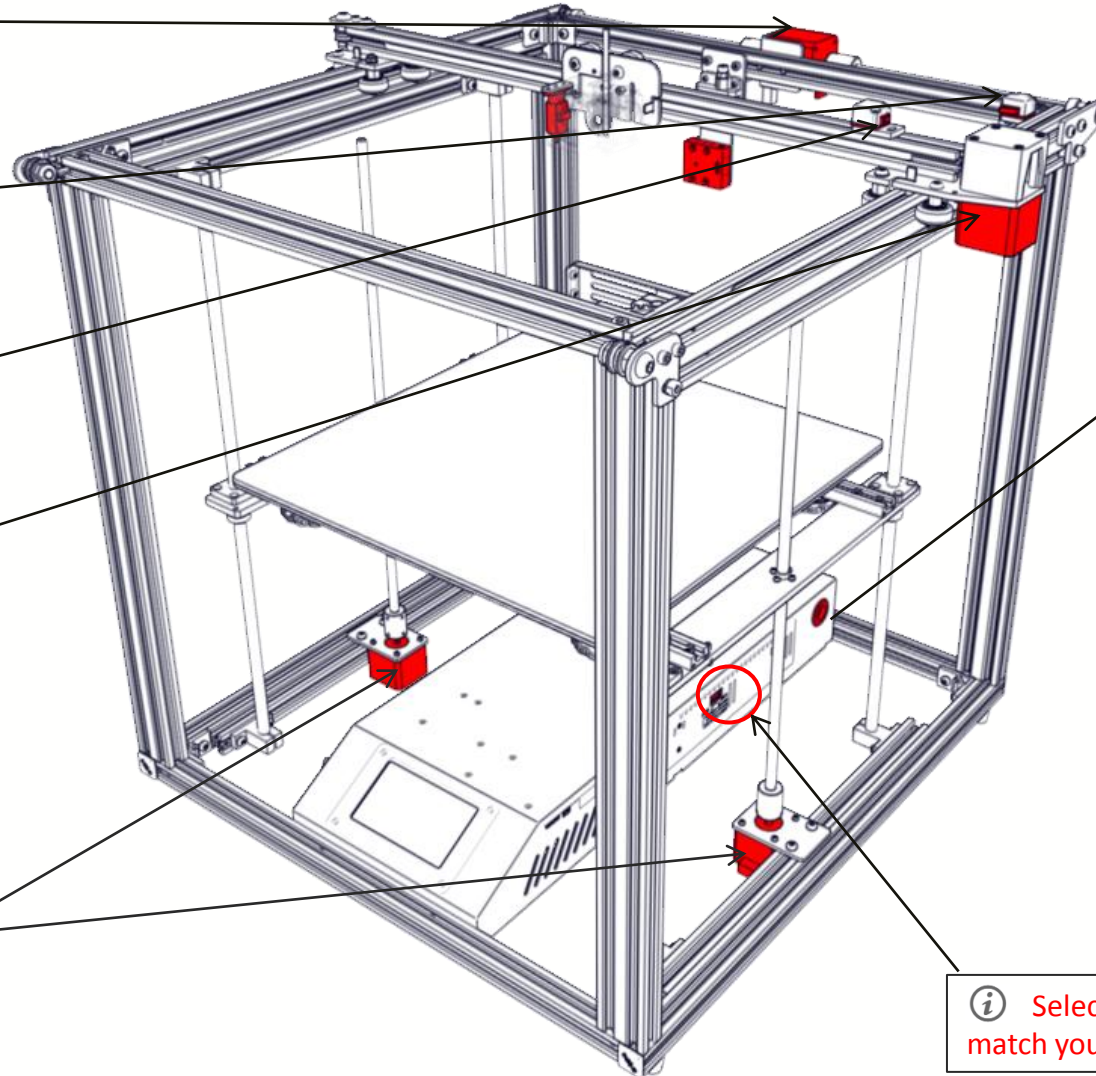
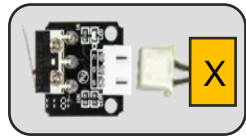
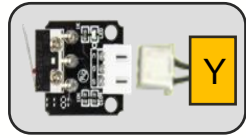

Nozzle Cable Connection



Bed Cable Connection



5Pin  
BL Touch Connection

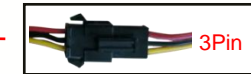

3Pin  
Broken filament detecting device Connection

**i** Select the correct input voltage to match your local mains (230V or 115V).

## Screen Information :

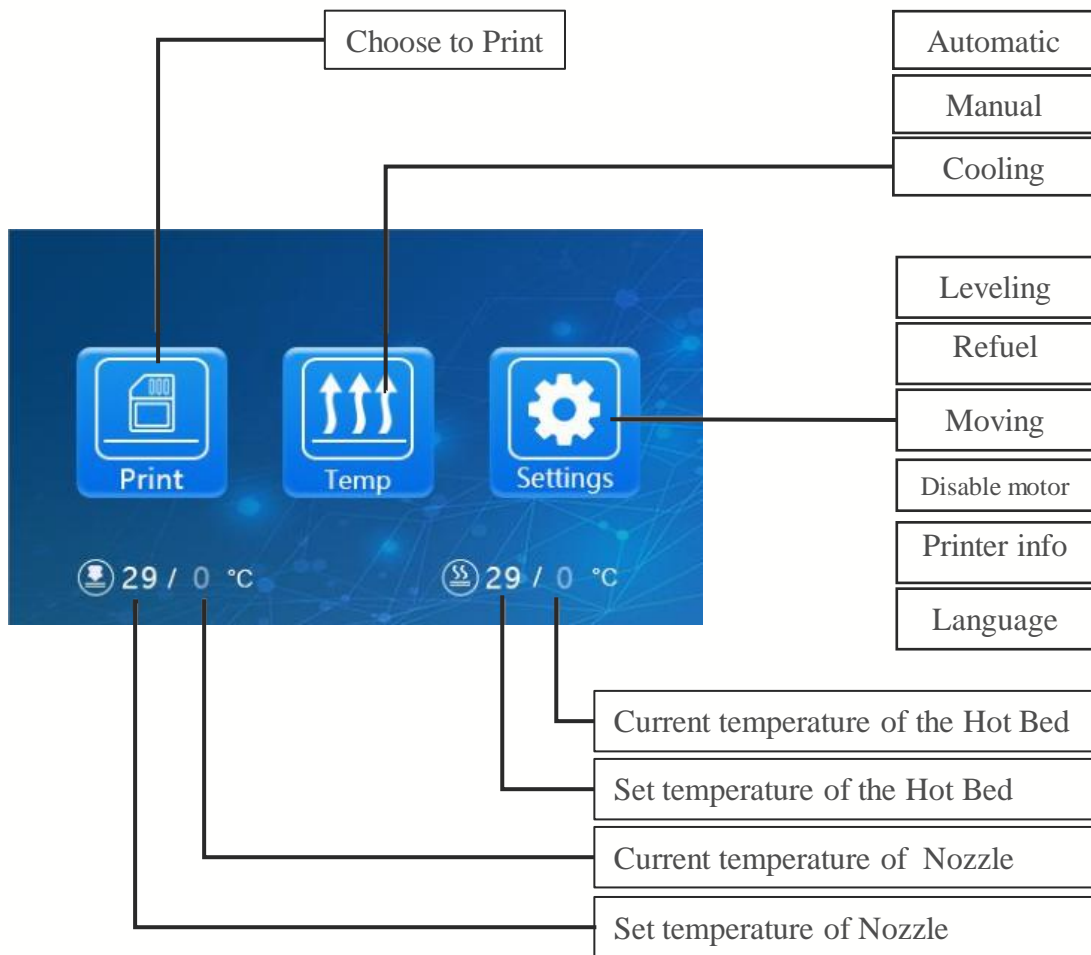

screen information					
Main Menu	Sub Menu	Explanation			
SD card	Selected file	Stop			
		Pause / Continue			
		Adjust	Print speed		
			Nozzle temp		
			Hot-bed temp		
			Z offset		
			fan		
fan(off/on)					
Temp	Automatic	PLA/ABS ( 185°\220° )			
	Manual	Nozzle preheat			
		Hot-bed preheat			
	Cooling	yes\no			
	Fan	(off/on)			
setting	Leveling	Z-axis : Z home , +0.1mm,-0.1mm			
		AUX leveling	Please click numbers to assist leveling (①~⑤)		
		Auto leveling	Auto leveling, please wait...		
		Check level ( Measurement parameters )			
	Refuel	Withdraw			
		Feed			
	Moving	X-axis	Y-axis	Z-axis	Z home
	Disable motor	yes\no			
	Language	English\Chinese			
	Printer info	Machine type、 Firmware version、 Printing size、 website			

## Loading Filament :

### 1. Preheat

Method 1

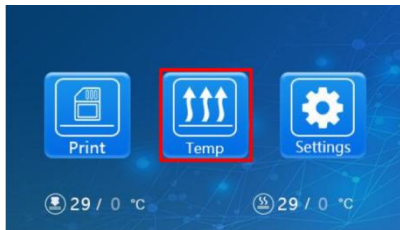

Method 2

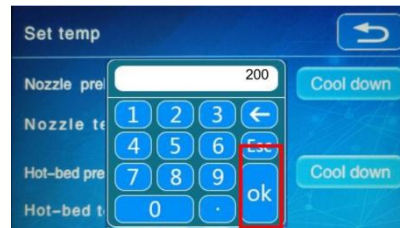
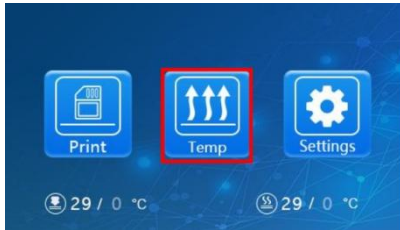

### 2. Feeding



Press and hold the extruder lever and insert the 1.75mm filament through the filament detector and through the extruder motor. Continue feeding until you see filament extrude from the nozzle.

#### Tip: How to replace the Filament?

- 1、Cutting filament near the Extruder and slowly feed new filament until they are fed into the new filament.
- 2、Preheating the nozzle and withdraw the filament quickly and feed the new filament.

## AUX leveling :

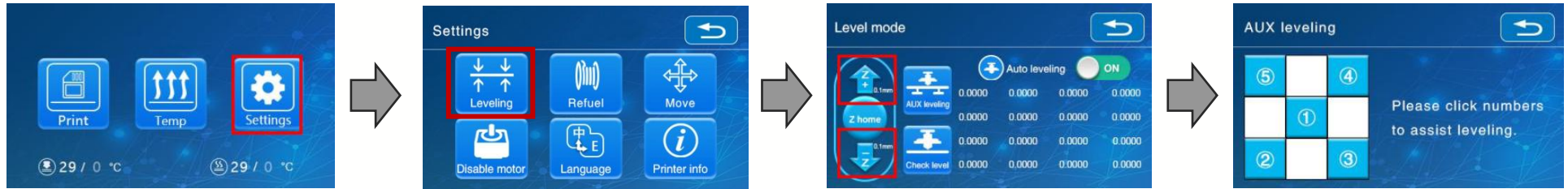

1. Slightly tighten the four leveling nuts at the bottom of the platform before initial leveling.
2. Select "Settings" → "Level mode" → "AUX leveling" , click on the number ②.

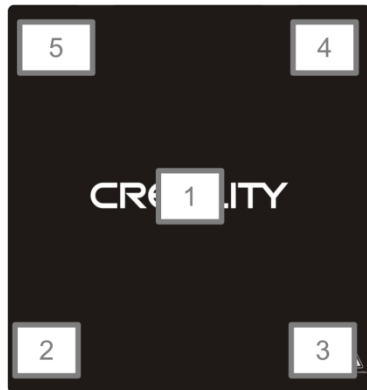

3. Adjust the platform height by turning the knob underneath. Use a piece of A4 paper (standard printer paper) to assist with the adjustment, making sure that the nozzle lightly presses on the paper.
4. Complete the adjustment on all 4 corners.
5. Click the number ① to test the platform height in the middle.
6. Repeat above steps one or two times if necessary.

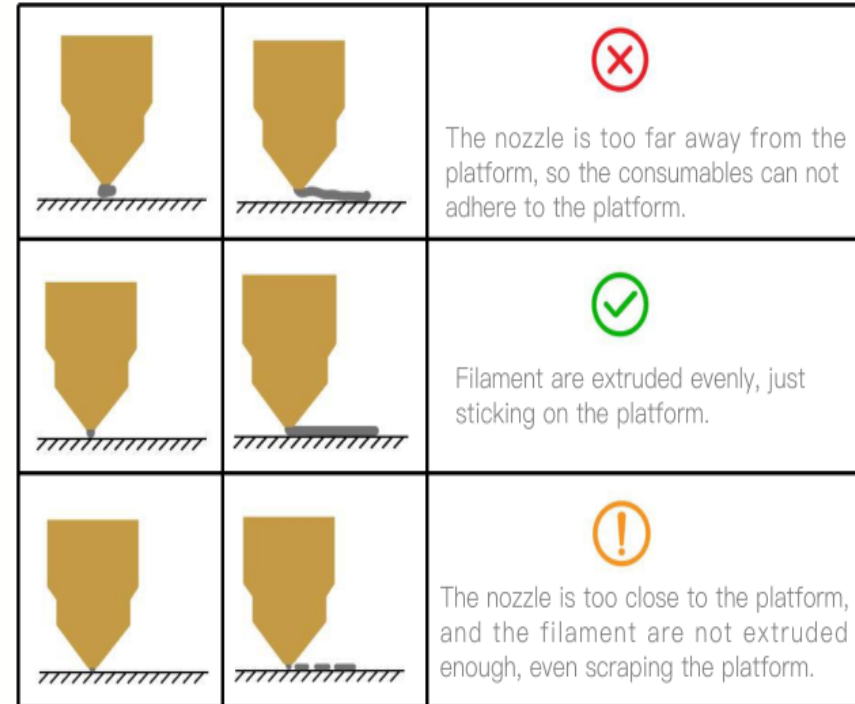

## Auto leveling :

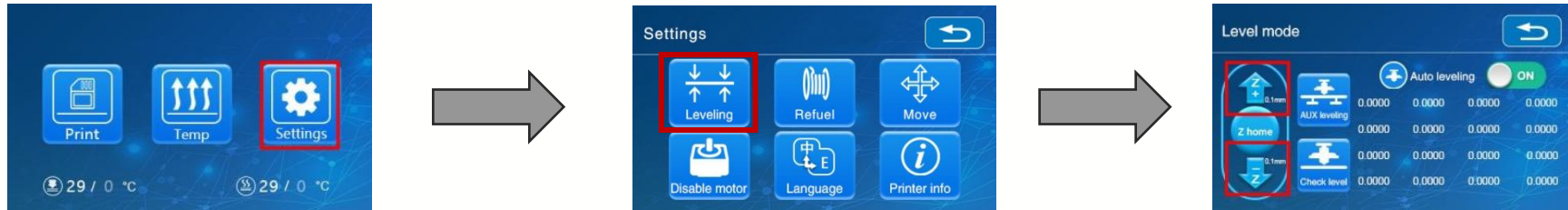

1. In “Settings” → “Leveling mode”
2. 2mm feeler gauge between the nozzle and the hot bed → If the gap is too thin or too large, click "Z+" or "Z-" on the interface to adjust the gap to slightly more than 0.2 mm(the distance between the nozzle and the hot bed should be about 0.2mm). At 0.2 mm the feeler can easily pass through the gap between the nozzle and the printing platform.

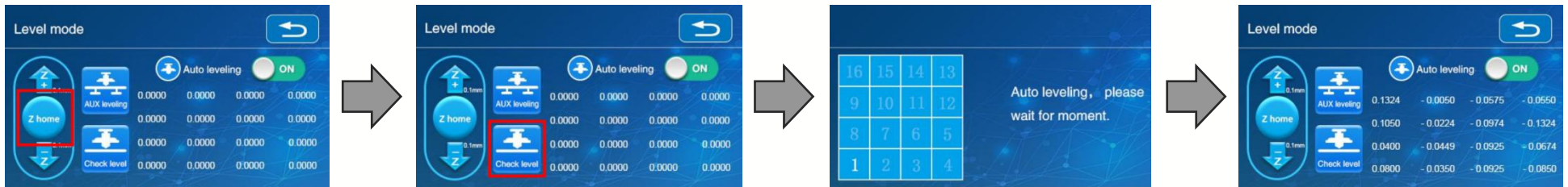

Restore hot end to original home position

Auto-level the printing surface

16 point precise bed height measurement

Printer will automatically compensate for variable bed height

\*When using the auto level feature , we suggest that adding a raft from the build plate adhesion section in software settings

## Software Installation :



Creality  
Slicer\_1.2.3

1. Double click to install the software.



Creality Slicer

2. Double click to open the software.

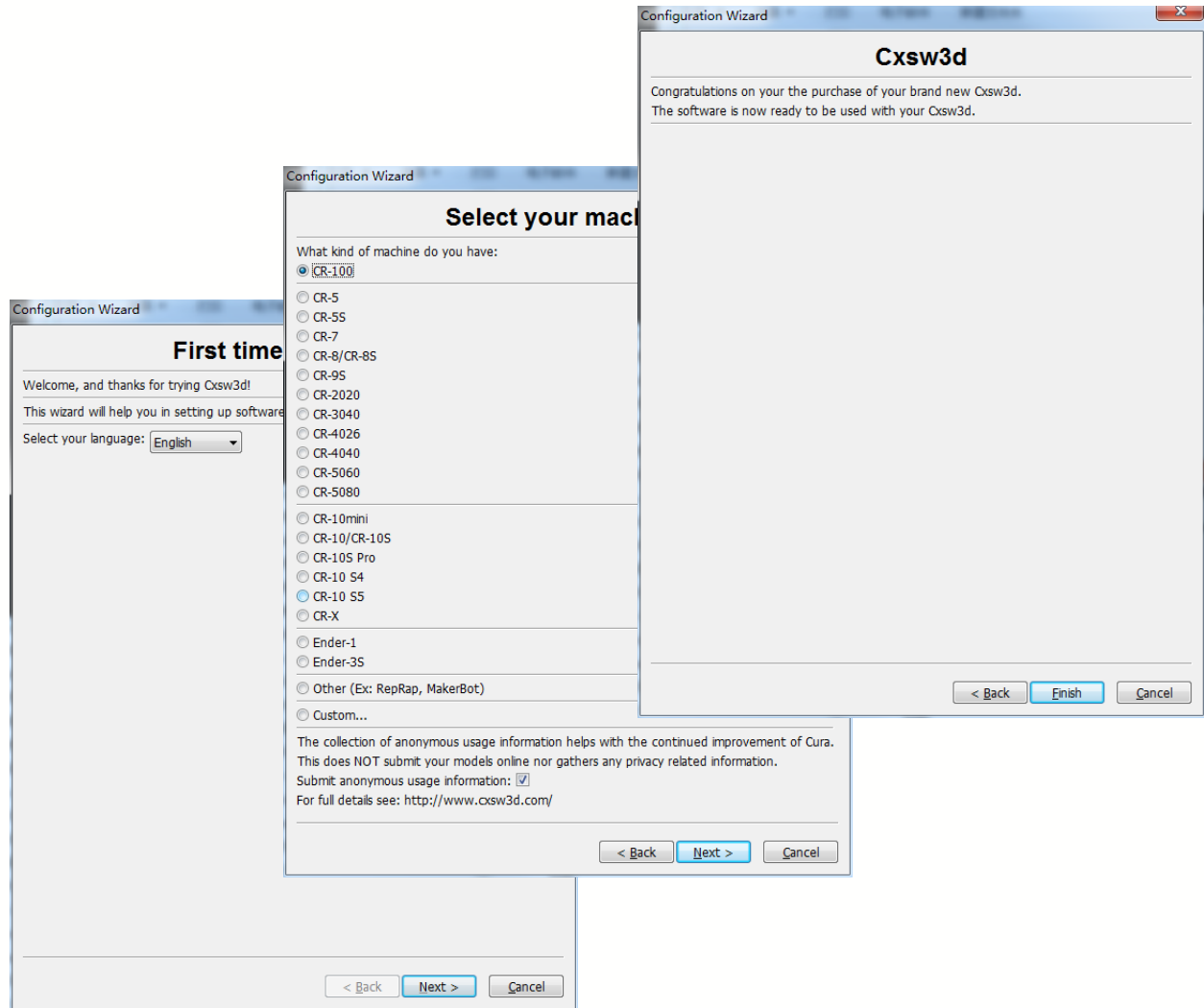

3. Select language → Next → Select your machine → Next → Finish.

## Preparing to Print :

### 1.Slicing

Insert TF card into computer with Reader.

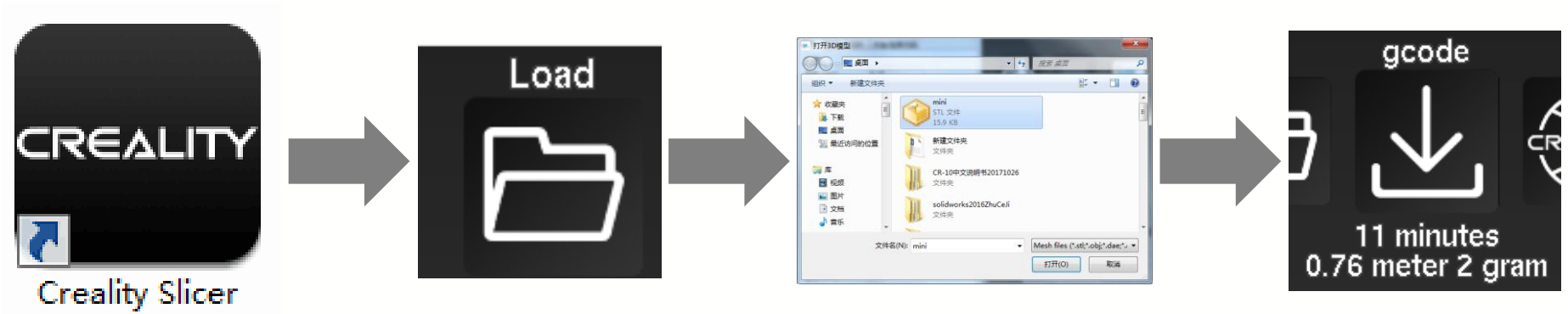

Open the software → Load → Select the file → Wait for slicing to finish ,and save the Gcode file to TF card.

### 2.Printing

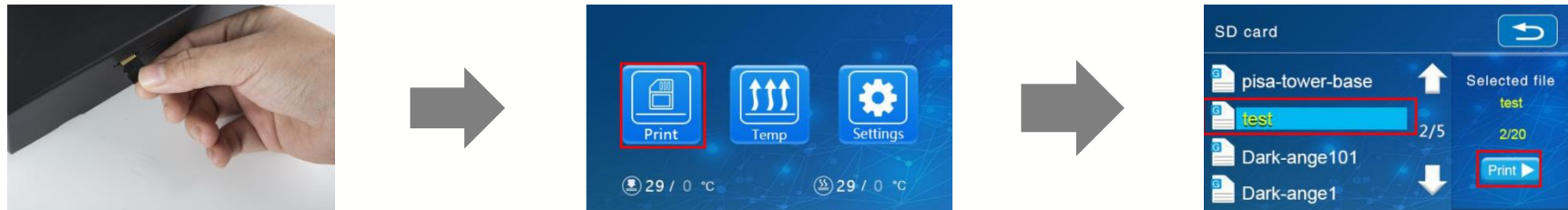

Insert the TF card → Select Print from TF → Select the file.



## Circuit Wiring :

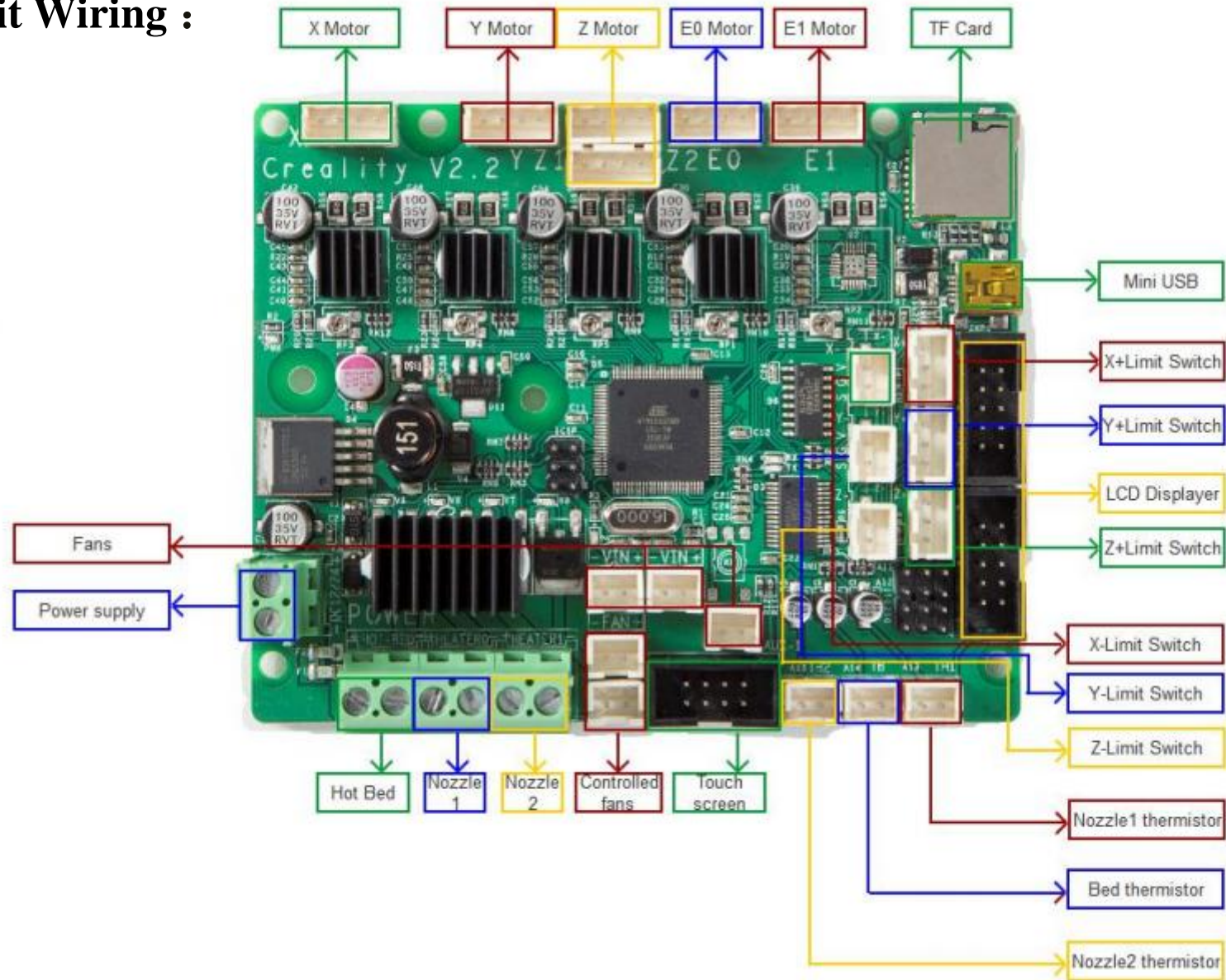



SHENZHEN CREALITY 3D TECHNOLOGY CO.,LTD.  
11F & Room 1201,Block 3,JinChengYuan,Tongsheng Community,Da  
lang,Longhua District,Shenzhen,China,518109  
Official Website: [www.creality3d.cn](http://www.creality3d.cn)  
Tel: +86 755-85234565  
E-mail: [info@creality3d.cn](mailto:info@creality3d.cn) [cs@creality3d.cn](mailto:cs@creality3d.cn)

