

Face milling cutters, 45°

For SEEN 1203, SEER 1203 indexable milling inserts

ATORN[®]

Application

Universal use in all materials.

Version

- Wear-resistant, nickel-plated version
- Indexable milling inserts for clamping using precision supports

Advantage

- Safe clamping with plate screw
- High cutting performance even in low-powered machines
- Variable pitch for smooth running

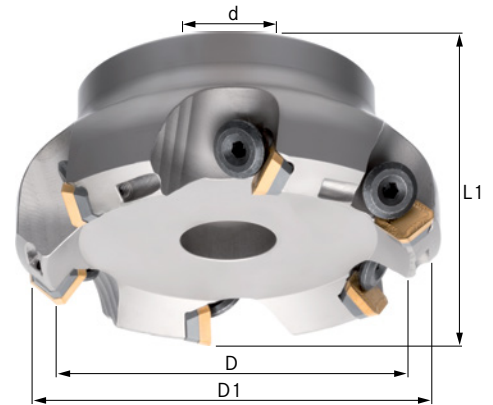

Art. No.	16022 200
Min. cutting edge diameter	200 mm
Max. cutting edge diameter	213 mm
Length	63 mm
Bore diameter	60 mm
max. ap	6 mm
Number of cutting edges	10 PCS

EAN-Code

4050293112702

