

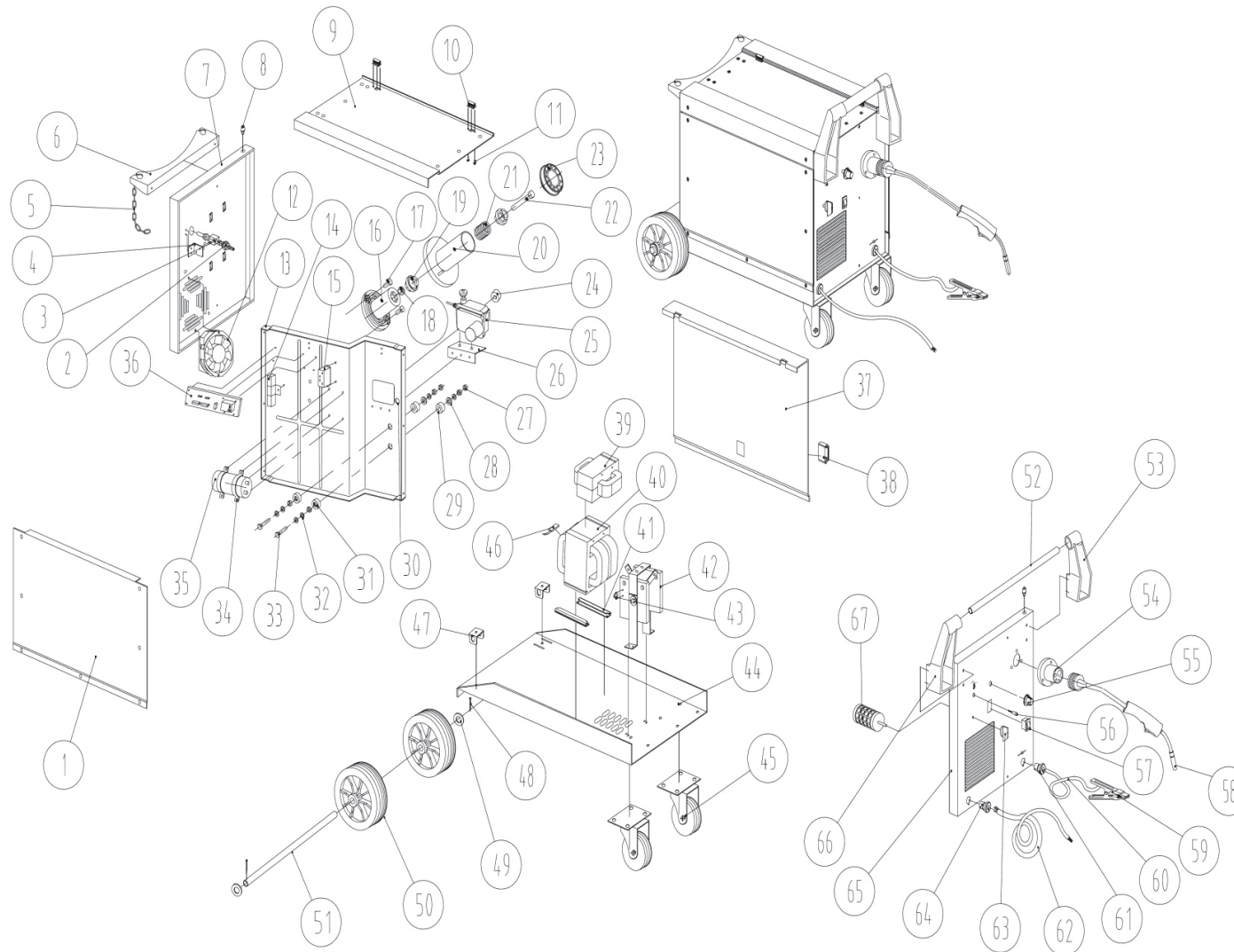

Parts Information:  
**Professional Gas/No-Gas MIG Welder 210Amp with Euro Torch**  
**Model No: MIGHTYMIG210.V2**



**NOTE:** It is our policy to continually improve products and as such we reserve the right to alter data, specifications and component parts without prior notice.

**IMPORTANT:** No liability is accepted for incorrect use of product.

**WARRANTY:** Guarantee is 12 months from purchase date, proof of which will be required for any claim.

Sealey Group, Kempson Way, Suffolk Business Park, Bury St Edmunds, Suffolk. IP32 7AR



01284 757500



01284 703534



sales@sealey.co.uk



www.sealey.co.uk



Parts Information:  
**Professional Gas/No-Gas MIG Welder  
210Amp with Euro Torch  
Model No: MIGHTYMIG210.V2**

Item	Part No.	Description
1	M/MIG210.01	SIDE PANEL
2	M/MIG210.02	VALVE ASSEMBLY
3	M-MIG210V2.03	VALVE CONNECTOR
4	M/MIG210.03	VALVE BRACKET
5	M/MIG210.04	CHAIN
6	M/MIG210.05	GAS BOTTLE SUPPORT
7	M/MIG210.06	BACK PANEL
8	M/MIG210.07	RUBBER SUPPORT
9	M/MIG210.08	TOP PANEL
10	M/MIG210.09A	HINGE (TWO SCREW FIXING)
11	FN8.S	FLANGE NUT SERRATED M8 ZINC (SINGLE)
12	M/MIG250.75	FAN
13	M/MIG210.13	INNER PANEL
14	M/MIG210.14	RESISTANCE
15	M/MIG210.15	RELAY
16	M/MIG210.16	SPINDLE FOR WIRE REEL
17	SS820.S	HEX HEAD SET SCREW M8x20mm SINGLE
18	SN10.S	STEEL NUT M10 ZINC DIN934(SINGLE)
19	M/MIG250.53	PLASTIC KNOB
20	M/MIG250.54	SPOOL HOLDER
21	M/MIG250.55	SPRING
22	HHB1080.S	HEX HEAD BOLT M10x80mm SINGLE
23	M/MIG250.56	RETAINER
24	SMIG275.52	WIRE FEEDER ROLLER 0.6-0.8mm
--	M/MIG210.24A	WIRE FEED ROLLER (0.9-1.0mm) (NOT SHOWN)
25	M/MIG250.60	WIRE FEED MOTOR
26	M/MIG210.26	WIRE FEED SUPPORT
27	SN8.S	STEEL NUT M8 ZINC DIN934 (SINGLE)
28	RW825.S	REPAIR WASHER M8x25 (SINGLE)
29	M/MIG250.36	INSULATING WASHER
30	M/MIG210.30	RUBBER RING
31	M/MIG250.38	INSULATING WASHER
32	RW825.S	REPAIR WASHER M8x25 (SINGLE)
33	M/MIG190.33	BOLT M8X55

Item	Part No.	Description
34	M/MIG210.34	CAPACITOR BRACKET
35	M/MIG250.76	CAPACITOR
36	M/MIG210.36	WIRE FEED PCB
37	M/MIG210.37	ACCESS PANEL
38	M/MIG250.73	LATCH
39	M/MIG210.39	FILTER REACTOR
40	M/MIG210.40	TRANSFORMER (SO)
41	M/MIG210.41	TRANSFORMER SUPPORT
42	M/MIG210.42	RECTIFIER(C/W SUPPORT)
43	M/MIG190.43	SWITCH
44	M/MIG210.44	BOTTOM PANEL
45	M/MIG250.06	WHEEL,CASTOR (75x10x32x116)
46	M/MIG210.46	THERMAL SWITCH
47	M/MIG210.47	AXLE BRACKET
48	M/MIG250.02	COTTER PIN
49	FWM20.S	FLAT WASHER M20 SINGLE
50	M/MIG250.04	WHEEL,FIXED (200x19x42)
51	M/MIG250.49	AXLE
52	M/MIG250.17	HANDLE
53	M/MIG250.13	HANDLE SUPPORT (RIGHT)
54	M/MIG250.11	TORCH HOLDER ASSEMBLY
55	M/MIG250.20	SPEED CONTROL KNOB
56	M/MIG210.56	OVERLOAD INDICATOR LIGHT, 24V, 24mA
57	M/MIG250.12	ON/OFF SWITCH
58	M-MIG210V2.58	EURO WELDING TORCH 3mtr - ERGO 15.2
59	M/MIG210.59	CLAMP (EARTH)
60	M/MIG210.60	EARTH CABLE
61	M/MIG210.61	CABLE GRIP
62	M/MIG210.62	LINE CABLE
63	M/MIG210.63	VOLTAGE CONTROL KNOB
64	M/MIG210.64	CABLE GRIP
65	M/MIG210.65	FRONT PANEL
66	M/MIG250.16	HANDLE SUPPORT (LEFT)
67	M/MIG250.23	VOLTAGE CONTROL SWITCH

**NOTE:** It is our policy to continually improve products and as such we reserve the right to alter data, specifications and component parts without prior notice.

**IMPORTANT:** No liability is accepted for incorrect use of product.

**WARRANTY:** Guarantee is 12 months from purchase date, proof of which will be required for any claim.

Sealey Group, Kempson Way, Suffolk Business Park, Bury St Edmunds, Suffolk. IP32 7AR



01284 757500



01284 703534



sales@sealey.co.uk



www.sealey.co.uk