

DD51-E | Electronic position indicators

direct drive, 5-digit display, technopolymer



- 1
- 2
- 3
- 4
- 5
- 6
- 7
- 8
- 9
- 10
- 11
- 12
- 13
- 14
- 15
- 16
- 17
- 18

BASE AND CASE

High-resistance polyamide based (PA) technopolymer.
Black base.

Case in the following colours:

- **C2:** RAL 2004 orange, glossy finish.
- **C3:** RAL 7035 grey, glossy finish.

Available on request in RAL 7021 grey-black colour (C1).

Cover with perfectly sealed gasket and AISI 304 stainless steel UNI 6955 type self-tapping screws with six-lobe socket TORX®T06 (registered trademark by TEXTRON INC.).

The ultrasonic welding between the base and the case prevents separation and avoids dust and liquid penetration.

BOSS

AISI 304 stainless steel with $\varnothing 14$ mm H7 reamed hole, fitting to shaft by means of AISI 304 stainless steel grub screw, hexagon socket and cup end UNI 5929-85, included in the supply.

WINDOW

Transparent polyamide based (PA-T) technopolymer, moulded over the case and with a perfect seal. Resistant to solvents, oils, greases and other chemical agents (avoid contact with alcohol during cleaning operations).

DISPLAY

- 5-digit LCD of 8 mm height and special characters.
- The visualization parameters can be set and modified by the operator by means of appropriate keys:
 - values displayed in mm, inches or degrees
 - display of mode for use (absolute or incremental mode)
 - reading orientation (right or reverse).

KEYBOARD

Polyester membrane. Resistant to solvents, alcohol, acids, alkalis.

INTERNAL GASKET

O-ring front sealing in NBR synthetic rubber, between the case and the boss.

Brass bushing with double O-ring sealing in NBR synthetic rubber inside the rear cavity of the base (DD51-E-SST-IP67).

REAR GASKET

Foam polyethylene, supplied.

STANDARD EXECUTIONS

- **DD51-E-SST-IP65:** completely sealed indicator with IP 65 protection class, see EN 60529 table (on page A-19).
- **DD51-E-SST-IP67:** completely sealed indicator with IP 67 protection class, see EN 60529 table (on page A-19) obtained by means of a brass bushing with double seal ring inside the rear cavity of the base.

ASSEMBLY INSTRUCTIONS

1. Drill a $\varnothing 6$ mm by 10 mm hole in the body of the machine with a 22 mm centre distance from the spindle to fit the rear referring pin.
2. Fit the indicator onto the spindle and make sure that the referring pin fit the hole.
3. Clamp the boss to the spindle by tightening the grub screw with hexagon socket and cup end, according to UNI 5929-85.



ELESA Original design

ACCESSORIES ON REQUEST (TO BE ORDERED SEPARATELY)

- **MDX-51:** polyamide based (PA) technopolymer knob.
- **RB51-SST:** AISI 304 stainless steel reduction sleeves.

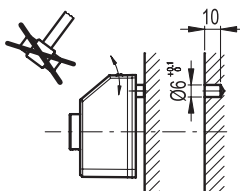
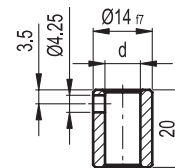

RB51-SST



Code	Description	dH7	
CE.95941	RB51-6-SST-304	6	20
CE.95951	RB51-8-SST-304	8	17
CE.95956	RB51-10-SST-304	10	11
CE.95961	RB51-12-SST-304	12	8

FEATURES AND APPLICATIONS

DD51-E position indicators, with battery power supply, can be used on passing through shafts in any position to provide the reading of the absolute or incremental positioning of a machine component.

The 5-digit display of 8,0 mm height ensures excellent readability even from a distance and from different viewing angles.

The window in transparent technopolymer protects the LCD display against accidental shocks.

The high protection degree, IP 65 or IP67, makes the indicator suitable for applications that require frequent washing, even with intense water jets.

In the operating mode, by using the 3 function keys, it is possible to select the incremental or the absolute mode, the unit of measure (mm, inches or degrees), reset the absolute counter or load a preset source value and the preset offset value.

In the programming mode, through the 3 function keys, it is possible to program the reading after one revolution of the shaft, the direction of rotation, the display orientation, the resolution (number of decimal digits displayed), the source value and the offset value, the max. speed of rotation and set the functions of the keys among different options available.

The internal battery ensures long battery life (over 5 years). A special symbol appears on the display when it is necessary to replace the battery. The replacement can be performed easily by removing the front cover (Fig.1), without disassembly of the indicator from the control shaft and without the loss of configuration parameters.

Further technical information available in "Operating instructions".

Mechanical and electrical characteristics	
Power supply	Lithium battery CR2450 3.0 V
Battery life	5 years
Display	5-digit LCD of 8 mm height and special characters
Reading scale	-19999; 99999
Number of decimal digits	programmable ⁽¹⁾
Unit of measure	mm, inches, degrees programmable ⁽¹⁾
Rotation max. speed	300/600/1000 r.p.m ⁽²⁾ programmable ⁽¹⁾
Precision	10.000 impulses / revolution
Protection class	IP65 or IP67
Working temperature	0 + 50 °C
Storing temperature	-20 + +60 °C
Relative humidity	Max. 95% at 25°C without condensation
Interference protection	Complies with Directive 2014/30/EU (EMC)

(1) See the operating instructions.

(2) Default: 600 r.p.m.

Higher rotation speed to 600 r.p.m. can be maintained for short periods of time.

The value of the max. speed affects the battery life.

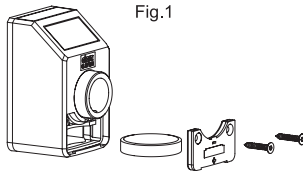
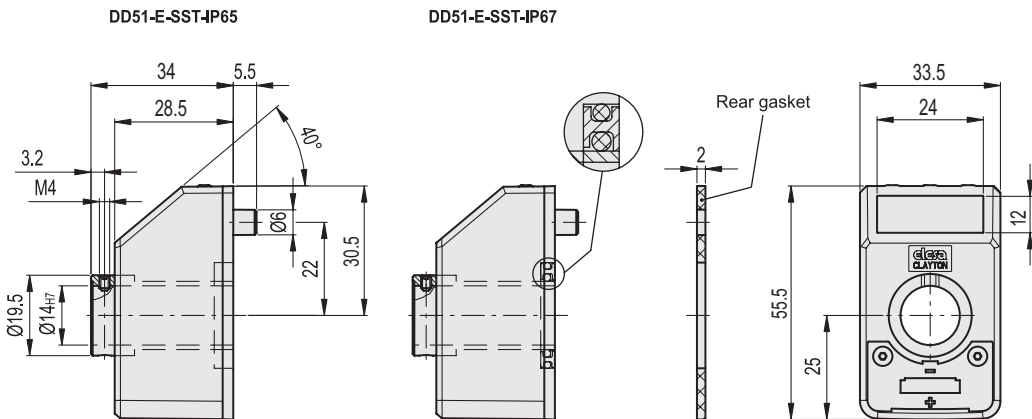

Fig.1



C2 RAL2004 C3 RAL7035

INOX STAINLESS STEEL

Code	Description	⚖
CE.99002	DD51-E-SST-IP65-C2	67
CE.99001	DD51-E-SST-IP65-C3	67
CE.99012	DD51-E-SST-IP67-C2	72
CE.99011	DD51-E-SST-IP67-C3	72