

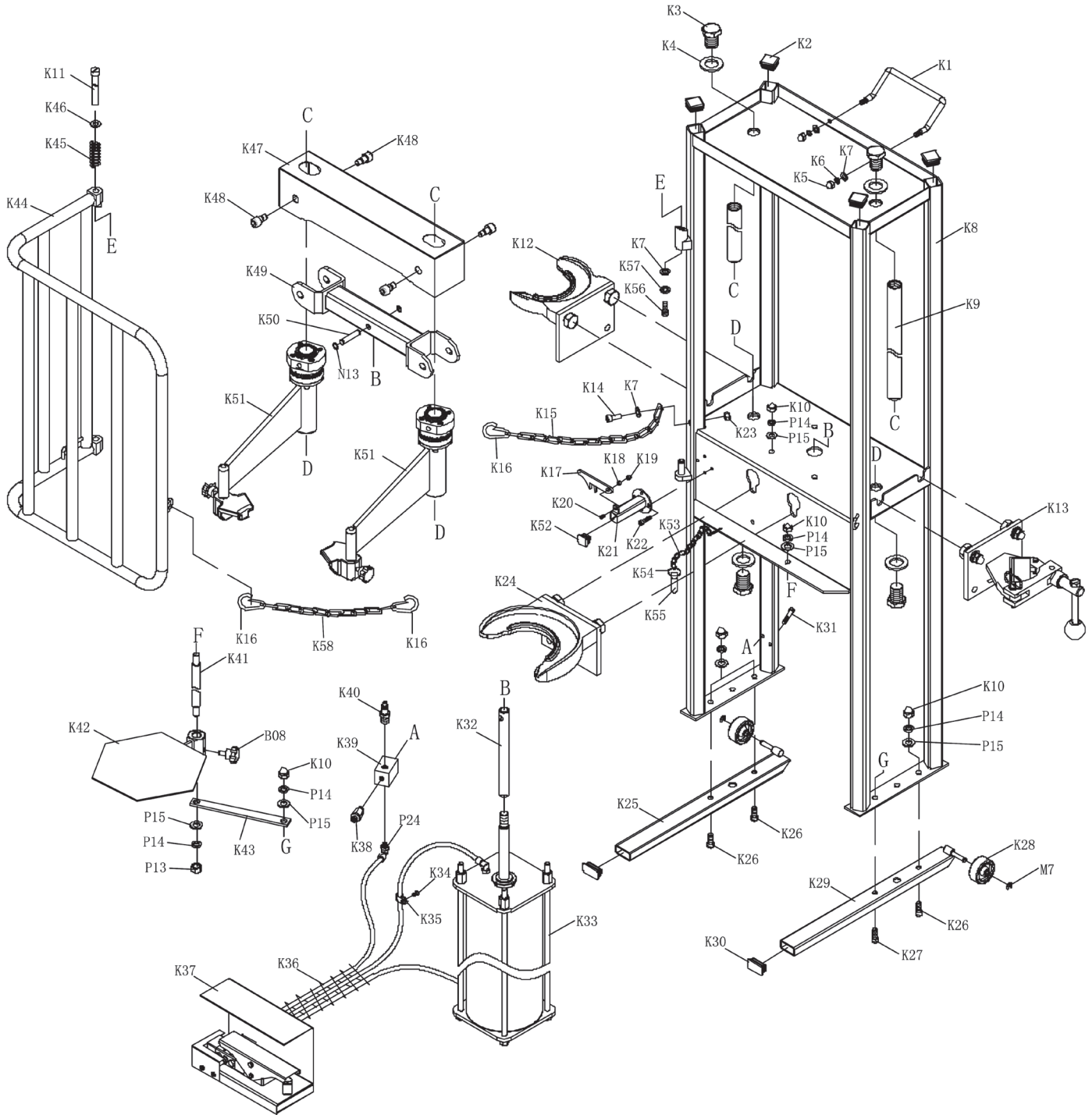

Parts Information:  
**Coil Spring Compressor -**  
**Air Operated 1000kg**  
**Model No: RE300.V2**



**NOTE:** It is our policy to continually improve products and as such we reserve the right to alter data, specifications and component parts without prior notice.

**IMPORTANT:** No liability is accepted for incorrect use of product.

**WARRANTY:** Guarantee is 12 months from purchase date, proof of which will be required for any claim.

Sealey Group, Kempson Way, Suffolk Business Park, Bury St Edmunds, Suffolk. IP32 7AR



01284 757500



01284 703534



sales@sealey.co.uk



www.sealey.co.uk



Parts Information:  
**Coil Spring Compressor -**  
**Air Operated 1000kg**  
**Model No: RE300.V2**

Item	Part No.	Description
B08	RE300.V2-B08	Knob Screw
K01	RE300.V2-K01	Handle
K02	RE300.V2-K02	End Plug
K03	SCB610.SB	Socket Cap Bolt Black M6x10
K04	FWM6.SB	Flat Washer M6 Black (single)
K05	SN8.SD	Steel Nut M8 Domed (single)
K06	SWM8.S	Spring Washer M8 Zinc (single)
K07	FWM8.S	Flat Washer M8 (single)
K08	RE300.V2-K08	Frame Ass'y
K09	RE300.V2-K09	Bar
K10	SN10.SD	Steel Nut M10 Domed (single)
K11	RE300.V2-K11	Pin
K12	RE300.V2-K12	Lower Yoke (small)
K13	RE300.V2-K13	Lower Strut Clamp
K14	RE300.V2-K14	Bolt
K15	RE300.V2-K15	Chain (A)
K16	RE300.V2-K16	Shackle
K17	RE300.V2-K17	Hook
K18	RE300.V2-K18	Copper Bushing
K19	NLN4.S	Nyloc Nut M4 Zinc din 985 (single)
K20	RE300.V2-K20	Bolt
K21	RE300.V2-K21	Hook Assembly
K22	SCB610.SB	Socket Cap Bolt Black M6x10
K23	NLN8.S	Nyloc Nut M8 Zinc din 985 (single)
K24	RE300.V2-K24	Lower Yoke (large)
K25	RE300.V2-K25	Base (1)
K26	RE300.V2-K26	Rd Head S/T Screw M4x22 Black
K27	SCB1020.SB	Socket Head Cap Screw M10x20 Black
K28	RE300.V2-K28	Wheel,Fixed (49x8x21)
K29	RE300.V2-K29	Base (2)
K30	RE300.V2-K30	End Plug, Base
K31	SCB640.SB	Socket Head Cap Screw M6x40 Black
K32	RE300.V2-K32	Connection Rod for Air Cylinder

Item	Part No.	Description
K33	RE300.V2-K33	Air Cylinder Ass'y
K34	MSP48.S	Machine Screw Pan Head Phillips M4x8mm (Single)
K35	RE300.V2-K35	Hose Clip
K36	RE300.V2-K36	Protective Casing
K37	RE300.V2-K37	Foot Pedal
K38	RE300.V2-K38	Safety Valve
K39	RE300.V2-K39	Valve Block
K40	RE300.V2-K40	Valve Block Connector
K41	RE300.V2-K41	Shaft for Plate
K42	RE300.V2-K42	Plate
K43	RE300.V2-K43	Connecting Rod
K44	RE300.V2-K44	Safety Locking Guard
K45	RE300.V2-K45	Spring
K46	RE300.V2-K46	Washer
K47	RE300.V2-K47	Moving Arm Cover
K48	RE300.V2-K48	Bolt
K49	RE300.V2-K49	Beam Ass'y
K50	RE300.V2-K50	Pin
K51	RE300.V2-K51	Moving Arm
K52	RE300.V2-K52	End Plug (white)
K53	RE300.V2-K53	Chain
K54	RE300.V2-K54	Ring
K55	RE300.V2-K55	Pin for Chain
K56	RE300.V2-K56	Screw
K57	SWM8.S	Spring Washer M8 Zinc (single)
K58	RE300.V2-K58	Chain (B)
M07	RE300.V2-M07	Cotter Pin
N13	RE300.V2-N13	Retaining Ring
P24	RE300.V2-P24	Hose Connector
P13	SN10.S	Steel Nut M10 Zinc din934 (single)
P14	SWM10.S	Spring Washer M10 Zinc (single)
P15	FWM10.S	Flat Washer M10 (single)

**NOTE:** It is our policy to continually improve products and as such we reserve the right to alter data, specifications and component parts without prior notice.

**IMPORTANT:** No liability is accepted for incorrect use of product.

**WARRANTY:** Guarantee is 12 months from purchase date, proof of which will be required for any claim.

**Sealey Group**, Kempson Way, Suffolk Business Park, Bury St Edmunds, Suffolk. IP32 7AR



01284 757500



01284 703534



sales@sealey.co.uk



www.sealey.co.uk