

20 mm (0.8 inch) General Purpose Seven Segment Displays

Technical Data

HDSP-815E
HDSP-816E
HDSP-815G
HDSP-816G

Features

- **Industry Standard Size**
- **Industry Standard Pin-Out**
15.24 mm (0.6 in.) DIP Leads on 2.54 mm (0.1 in.) Centers
- **Choice of Colors**
Red, Green
- **Mitered Font**
Mitered Corners on Segments
- **Gray Face Paint**
Gray Package Gives Optimum Contrast
- **± 50° Viewing Angle**
- **Design Flexibility**
Common Anode or Common Cathode
- **Categorized for Luminous Intensity**

Applications

- **Suitable for Indoor Use**
- **Not Recommended for Industrial Applications, i.e. Operating Temperatures Exceeding 85°C or Below -25°C^[1]**
- **Extreme Temperature Cycling Not Recommended^[2]**

Description

These 20 mm (0.8 inch) displays use industry standard size and pin-out. The devices are available as either common anode or common cathode. Available in either red or green colors, these gray-faced displays are suitable for indoor use.



No color binning is offered for these parts.

These parts are subjected to Outgoing Quality Assurance (OQA) inspection with AQL of 0.065% for functional and visual/cosmetic rejects.

Devices

HER HDSP-	Green HDSP-	Description
815E	815G	Common Anode Right Hand Decimal
816E	816G	Common Cathode Right Hand Decimal

Notes:

1. For industrial applications, it is recommended to use HDSP-3901/3903/8601/8603.
2. For details, please contact your local Agilent Technologies sales office or an authorized distributor.

Part Numbering System

5082 -X X X X-X X X X X

HDSP-X X X X-X X X X X

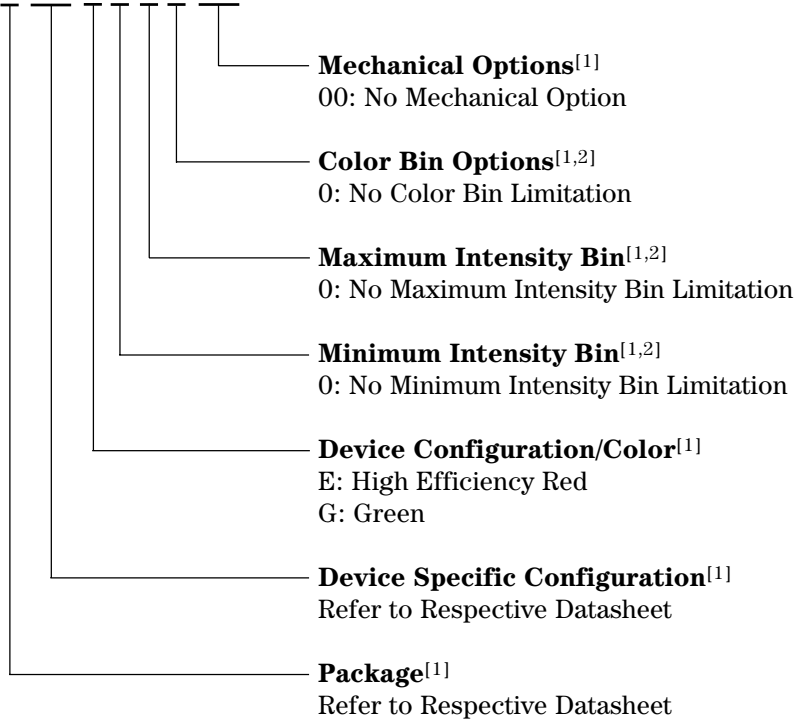

Notes:

1. For codes not listed in the figure above, please refer to the respective datasheet or contact your nearest Agilent representative for details.
2. Bin options refer to shippable bins for a part number. Color and Intensity Bins are typically restricted to 1 bin per tube (exceptions may apply). Please refer to respective datasheet for specific bin limit information.

Package Dimensions

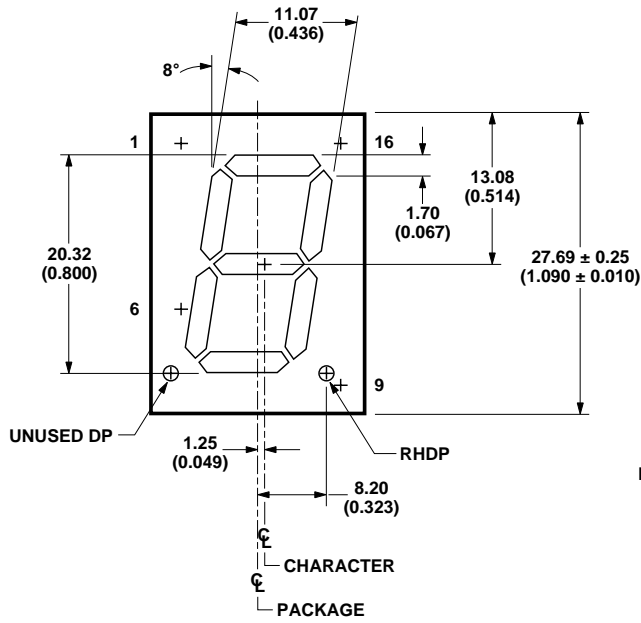

FRONT VIEW

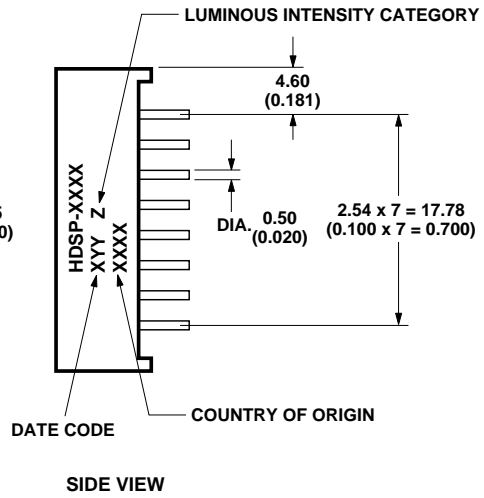

SIDE VIEW

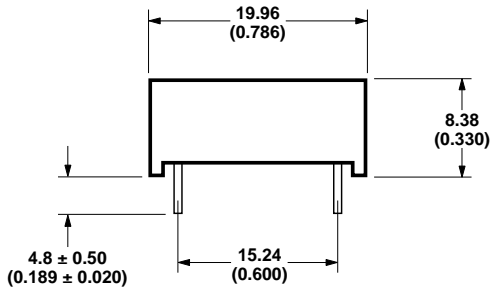

END VIEW

NOTES:

1. DIMENSIONS IN MILLIMETERS AND (INCHES).
2. TOLERANCE IS 0.25 mm (0.010 INCH) UNLESS OTHERWISE STATED.

Internal Circuit Diagram

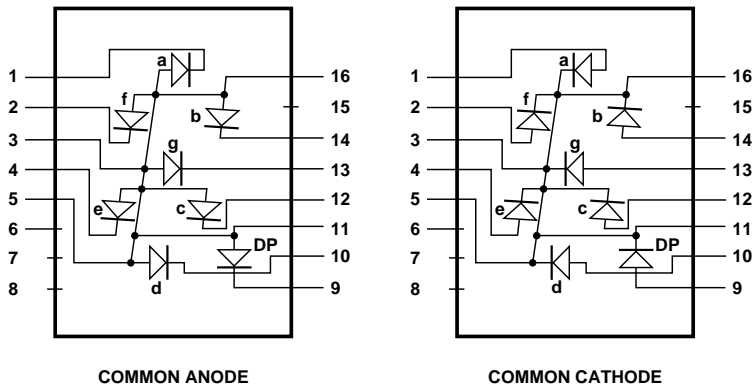

COMMON ANODE		COMMON CATHODE	
PIN	FUNCTION	PIN	FUNCTION
1	CATHODE A	1	ANODE A
2	CATHODE F	2	ANODE F
3	COMMON ANODE	3	COMMON CATHODE
4	CATHODE E	4	ANODE E
5	COMMON ANODE	5	COMMON CATHODE
6	NO CONNECTION	6	NO CONNECTION
7	NO PIN	7	NO PIN
8	NO PIN	8	NO PIN
9	CATHODE RHDP	9	ANODE RHDP
10	CATHODE D	10	ANODE D
11	COMMON ANODE	11	COMMON CATHODE
12	CATHODE C	12	ANODE C
13	CATHODE G	13	ANODE G
14	CATHODE B	14	ANODE B
15	NO PIN	15	NO PIN
16	COMMON ANODE	16	COMMON CATHODE

Absolute Maximum Ratings at $T_A=25^\circ\text{C}$

Parameter	High Efficiency Red HDSP-815E HDSP-816E	Green HDSP-815G HDSP-816G	Units
Average Power per Segment or DP	62.5	65	MW
Peak Forward Current per Segment or DP (1/10 Duty Cycle, 0.1 ms Pulse Width)	100	90	mA
DC Forward Current per Segment or DP ^[1]	25	25	mA
Reverse Voltage per Segment or DP	3	3	V
Operating Temperature	-25 to +85	-25 to +85	$^\circ\text{C}$
Storage Temperature	-25 to +85	-25 to +85	$^\circ\text{C}$
Wave Soldering Temperature for 3 Seconds ^[2] (1.6 mm [0.063 in.] below Body)	250	250	$^\circ\text{C}$

Notes:

- Derate above 25°C at $0.33\text{ mA}/^\circ\text{C}$.
- Not recommended to be soldered more than 2 times. Minimum interval between solderings is 15 minutes. Total soldering time not to exceed 5 seconds.

Optical/Electrical Characteristics at $T_A=25^\circ\text{C}$

High Efficiency Red

Devices HDSP-	Parameter	Symbol	Min.	Typ.	Max.	Units	Test Conditions
815E 816E	Luminous Intensity/Segment (Segment Average) ^[1,2]	I_V	2.3	4.8		mcd	$I_F = 20\text{ mA}$
	Forward Voltage/Segment or DP	V_F		2.1	3.0	V	$I_F = 20\text{ mA}$
	Peak Wavelength	λ_{PEAK}		635		nm	
	Dominant Wavelength ^[3]	λ_d		626		nm	
	Reverse Voltage/Segment or DP ^[4]	V_R	3.0	25		V	$I_R = 100\ \mu\text{A}$
	Temperature Coefficient of V_F /Segment or DP	$\Delta V_F/^\circ\text{C}$		-2		mV/ $^\circ\text{C}$	

Green

Devices HDSP-	Parameter	Symbol	Min.	Typ.	Max.	Units	Test Conditions
815G 816G	Luminous Intensity/Segment (Segment Average) ^[1,2]	I_V	1.5	3.3		mcd	$I_F = 20\text{ mA}$
	Forward Voltage/Segment or DP	V_F		2.1	2.6	V	$I_F = 20\text{ mA}$
	Peak Wavelength	λ_{PEAK}		566		nm	
	Dominant Wavelength ^[3]	λ_d		571		nm	
	Reverse Voltage/Segment or DP ^[4]	V_R	3.0	50		V	$I_R = 100\ \mu\text{A}$
	Temperature Coefficient of V_F /Segment or DP	$\Delta V_F/^\circ\text{C}$		-2		mV/ $^\circ\text{C}$	

Notes:

- Case temperature of the device immediately prior to the intensity measurement is 25°C .
- The digits are categorized for luminous intensity. The intensity category is designated by a letter on the side of the package.
- The dominant wavelength, λ_d , is derived from the CIE chromaticity diagram and represents the single wavelength which defines the color of the device.
- Typical specification for reference only. Do not exceed absolute maximum ratings.

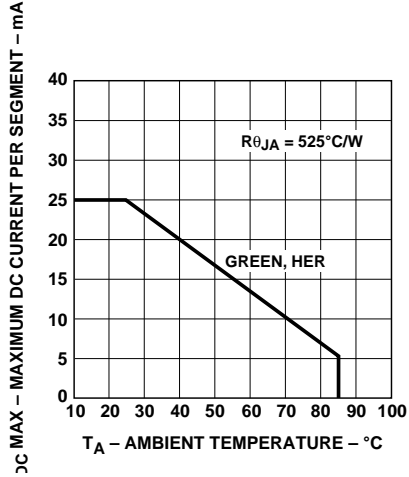

Figure 1. Maximum Allowable DC Current vs. Ambient Temperature.

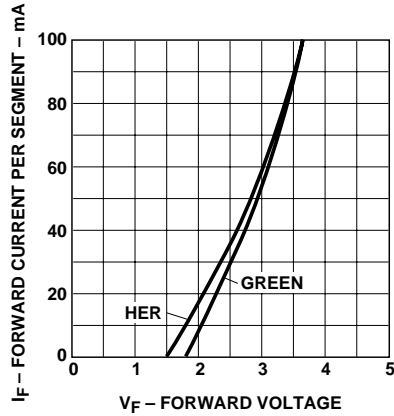

Figure 2. Forward Current vs. Forward Voltage.

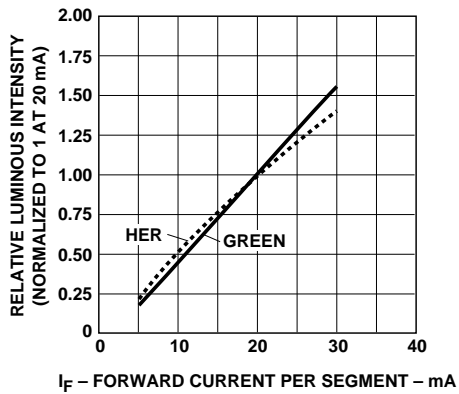

Figure 3. Relative Luminous Intensity vs. DC Forward Current.

Intensity Bin Limits (mcd at 20 mA) HER/Green

Bin Name	Green		HER	
	Min. ^[1]	Max. ^[1]	Min. ^[1]	Max. ^[1]
N	NA	NA	5.31	7.57
P	7.57	10.78	7.57	10.78
Q	10.78	15.10	10.78	15.10
R	15.10	21.58	NA	NA

Color Categories

Color	Bin	Dominant Wavelength (nm)	
		Min.	Max.
Green	1	569.00	572.00
	2	572.00	575.00

Note:

- All categories are established for classification of products. Products may not be available in all categories. Please contact your Agilent representative for further clarification/information.

Contrast Enhancement

For information on contrast enhancement, please see Application Note 1015.

Soldering/Cleaning

Cleaning agents from the ketone family (acetone, methyl ethyl ketone, etc.) and from the chlorinated hydrocarbon family (methylene chloride, trichloroethylene, carbon tetrachloride, etc.) are not recommended for cleaning LED parts. All of these various solvents attack or dissolve the encapsulating epoxies used to form the package of plastic LED parts.

For information on soldering LEDs please refer to Application Note 1027.

Device Reliability

For reliability information, please see the reliability data sheet 20 mm (0.8 inch) General Purpose Seven Segment Display.

www.agilent.com/semiconductors

For product information and a complete list of distributors, please go to our web site.

For technical assistance call:

Americas/Canada: +1 (800) 235-0312 or
(916) 788-6763

Europe: +49 (0) 6441 92460

China: 10800 650 0017

Hong Kong: (+65) 6756 2394

India, Australia, New Zealand: (+65) 6755 1939

Japan: (+81 3) 3335-8152 (Domestic/International), or 0120-61-1280 (Domestic Only)

Korea: (+65) 6755 1989

Singapore, Malaysia, Vietnam, Thailand,
Philippines, Indonesia: (+65) 6755 2044

Taiwan: (+65) 6755 1843

Data subject to change.

Copyright © 2004 Agilent Technologies, Inc.

Obsoletes 5988-4353EN

July 17, 2004

5988-7999EN