

59135 Series

High Temperature Flange Mount Sensor



Description

The 59135 is a high temperature flange mounting reed sensor 28.57mm x 19.05mm x 6.35mm (1.125" x 0.750" x 0.250") with a choice of normally open, normally closed or change-over contacts. It is rated for operation up to 150°C and capable of switching up to 265Vac/300Vdc at 10VA.

The 59135 series is well suited for use in a wide range of industrial, appliances, or IoT proximity sensing applications.

Note: The 59135 series functions best with the matching actuator 57135-000.

Features & Benefits

- Non-contact switching solution for wet & harsh environments
- Rated up to 150C operating temperature
- Housing design for optimum adjustability
- Available in select sensitivities (operating distances)
- Standard Teflon insulated cable configurations; customization options available
- Thermoset overmold material
- Hermetically sealed, IP67 rated; UL and REACH compliant
- No leakage current in 'open' state—ideal for battery powered IoT applications
- Can operate through non-ferrous materials (for example, wood, plastic or aluminium)
- Helps implement efficient proximity/access and energy management systems
- Compact size and easy installation and effective concealment in many applications
- UL Recognized per UL 508 and CSA C22.2 No. 14.

Additional Information



Resources



Accessories



Samples

Dimensions

Dimensions in mm (inch)

Tolerances are +/- 0.25 (0.010) unless otherwise noted.

Actuator

(sold separately)

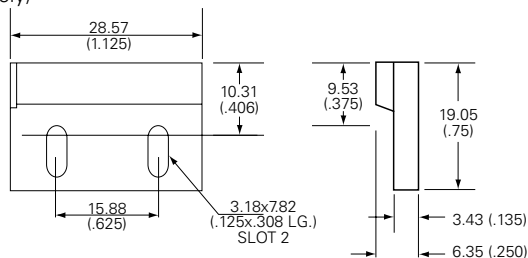

Sensor

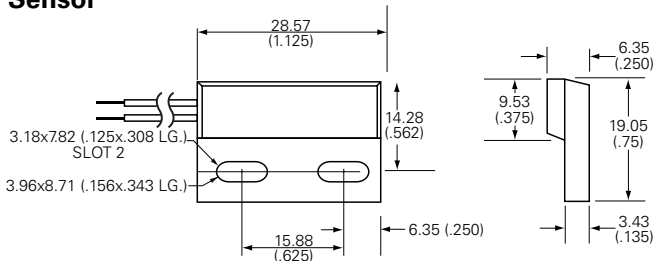

Applications

- Security and access control
- Factory automation
- Process equipment
- Major appliances
- Small appliances
- Proximity and limit sensing

Agency Approvals

Agency	Agency File Number
	E61760

Note: Contact Littelfuse for specific agency approval ratings.

Schematics	Switch Type
	1 and 2
	3
	4

59135 Series

High Temperature Flange Mount Sensor

Electrical Ratings

Contact Type			Normally Open	Normally Open High Voltage	Change Over	Normally Closed
Switch Type			1	2	3	4
Contact Rating ¹		VA/Watt - max.	10	10	5	5
Voltage ⁴	Switching ²	Vdc - max.	200	200	175	175
		Vac - max.	140	265	120	120
	Breakdown ³	Vdc - min.	250	400	200	200
Current ⁴	Switching ²	Adc - max.	0.5	0.4	0.25	0.25
		Aac - max.	0.35	0.30	0.18	0.18
	Carry	Adc - max.	1.2	1.4	1.5	1.5
Resistance ⁵	Contact, Initial Insulation	Ω - max.	0.2	0.2	0.2	0.2
		Ω - min.	10 ¹⁰	10 ¹⁰	10 ⁹	10 ⁹
Capacitance	Contact	pF - typ.	0.3	0.2	0.3	0.3
Temperature	Operating	°C	-40 to +150	-20 to +150	-40 to +150	-40 to +150

Product Characteristics

Operate Time ⁶		ms - max.	1.0	1.0	3.0	3.0
Release Time ⁶		ms - max.	1.0	1.0	3.0	3.0
Shock ⁷	11ms ½ sine	G - max.	100	100	50	50
Vibration ⁷	50-2000 Hz	G - max.	30	30	30	30

Notes:

- Contact rating - Product of the switching voltage and current should never exceed the wattage rating. Contact Littelfuse for additional load/life information.
- When switching inductive and/or capacitive loads, the effects of transient voltages and/or currents should be considered. Refer to Application Notes AN108A and AN107 for details.
- Breakdown Voltage - per MIL-STD-202, Method 301.
- Electrical Load Life Expectancy - Contact Littelfuse with voltage, current values along with type of load.
- This resistance value is for 300 mm wire length. Resistance changes when wire lengthens.
- Operate (including bounce)/Release Time - per EIA/NARM RS-421-A, diode suppressed coil (Coil II).
- Shock and Vibration - per EIA/NARM RS-421-A and MIL-STD-202.
- For custom modifications to the wire length or size, or adding a special connector, please contact Littelfuse.

Sensitivity Options (Using 57135 Actuator)

Select Option	S			T			U			V		
	Pull-In AT Range	Activation Distance (mm) Min.	Deactivation Distance (mm) Max.	Pull-In AT Range	Activation Distance (mm) Min.	Deactivation Distance (mm) Max.	Pull-In AT Range	Activation Distance (mm) Min.	Deactivation Distance (mm) Max.	Pull-In AT Range	Activation Distance (mm) Min.	Deactivation Distance (mm) Max.
1 Normally Open	12-18	12.5	28.51	17-23	12	27.51	22-28	10.5	24	27-33	9.5	22.5
2 High Voltage	-	-	-	17-23	12	27.51	22-28	10.5	24	27-33	9.5	22.5
3 Change Over	15-20	10	26	20-25	9	25	25-30	7.49	22.5	-	-	-
4 Normally Closed	15-20	10	26	20-25	8.99	25	25-30	7.49	22.5	-	-	-

Notes:

- Pull-In AT Range: These AT values are the bare reed switch AT before modification.
- The activation distance is average value on the final sensor assembly.

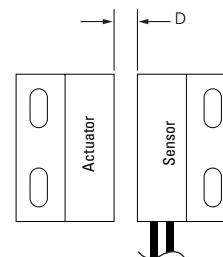

59135 Series

High Temperature Flange Mount Sensor

Cable Length Specification

Cable Type: 20 AWG 19/32 FEP UL1130/UL1332	
Select Option	Cable Length mm (inch)
02	300 +/-10.00 (11.81 +/- 0.394)
05	1000+/-10.00 (39.37+/- 0.394)

Termination Specification

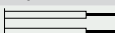
Termination Options		
Select Option	Description (Two-wire versions illustrated)	
A	Tinned leads (6.4±0.76)mm	

Material Specification

	Housing Material	Color	Sealing Component
57135 Actuator	Thermoset Epoxy	Black	Epoxy
59135 Sensor	Thermoset Epoxy	Black	Epoxy

Packaging

Cable Length	Packaging Option	Quantity
02	Bulk	500
05	Bulk	500

Recommended Fastener for Sensor¹

Series	Fastener	Type	Torque
Metric	M3	Screw with washer	1.0 N-m
Standard	#4 (7/64")	Screw with washer	8.85 in-lbf

Note: 1. Sensor Housing may be secured using mechanical fasteners, M3 or #4 Screws (Torque to 1 N-m (8.9 in-lbf)), or suitable adhesive tape material. Please note that you must use a suitable washer with the mechanical fastener. Fastener material should be non-magnetic stainless steel or brass.

Part Numbering System

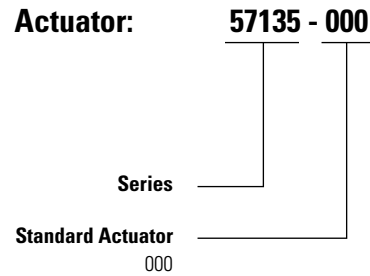
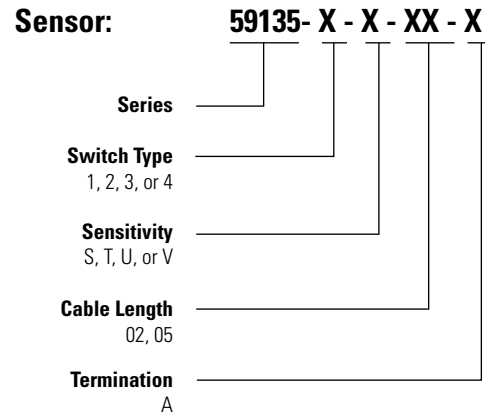

Note: The 57135 Actuator is sold separately.