

- 1
- 2
- 3
- 4
- 5
- 6
- 7
- 8
- 9
- 10
- 11
- 12
- 13
- 14
- 15
- 16
- 17
- 18

COMPONENTS

T-shaped connecting shanks, connecting joints and end shanks in aluminium die-cast coated.

Epoxy resin coating, black colour, semi-matte finish

Front mounting, tapped holes for M12x80 screws and washers in zinc-plated and passivate steel, included in the supply.

TUBE

Aluminium, fine ground surface, natural colour anodised, satin finish.

FEATURES AND APPLICATIONS

The end shanks and the T-shaped connecting shanks have one or two holes, respectively, for housing a positioning dowel $\varnothing 4 \times 10$ to effectively prevent the part from rotating.

ORDER INFORMATION

When ordering, the code of the tube and its components should be specified.

SPECIAL EXECUTIONS ON REQUEST

- Aluminium tube of different lengths.
- Version with AISI 304 stainless steel screws, nuts and washers.
- Aluminium tube covered with epoxy resin, black colour, semi-matte finish.

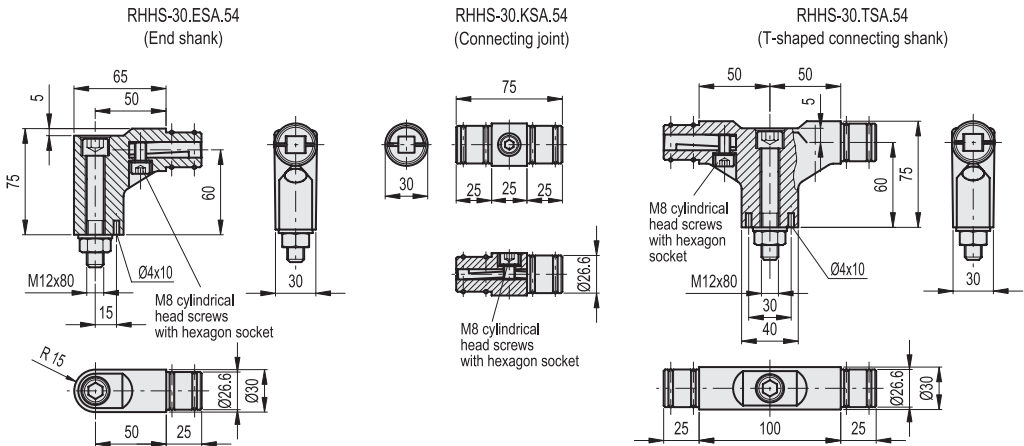

RH-HS-30

| Code | \triangle |
|----------------|-------------|
| RHHS-30.ESA.54 | 363 |
| RHHS-30.KSA.54 | 155 |
| RHHS-30.TSA.54 | 565 |

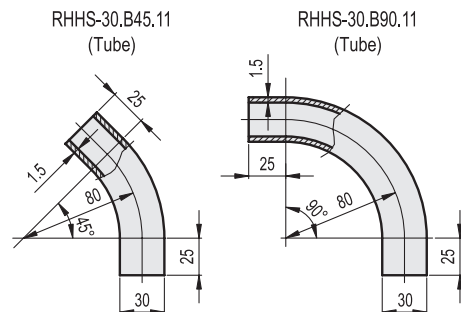
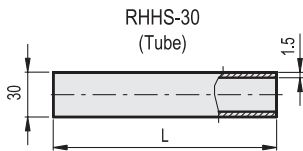

RH-HS-30-T

| Code | L | \triangle |
|----------------|-----|-------------|
| RHHS-30.200.11 | 200 | 71 |
| RHHS-30.300.11 | 300 | 106 |
| RHHS-30.400.11 | 400 | 141 |
| RHHS-30.500.11 | 500 | 180 |
| RHHS-30.600.11 | 600 | 210 |
| RHHS-30.700.11 | 700 | 245 |

RH-HS-30-C

| Code | \triangle |
|----------------|-------------|
| RHHS-30.B45.11 | 39 |
| RHHS-30.B90.11 | 62 |