

METRATESTER[®] 5 and 5-F

Tester for DIN VDE 0701-1:2000 and 0702:1995

3-348-580-15
12/3.04



METRATESTER®5/5-F

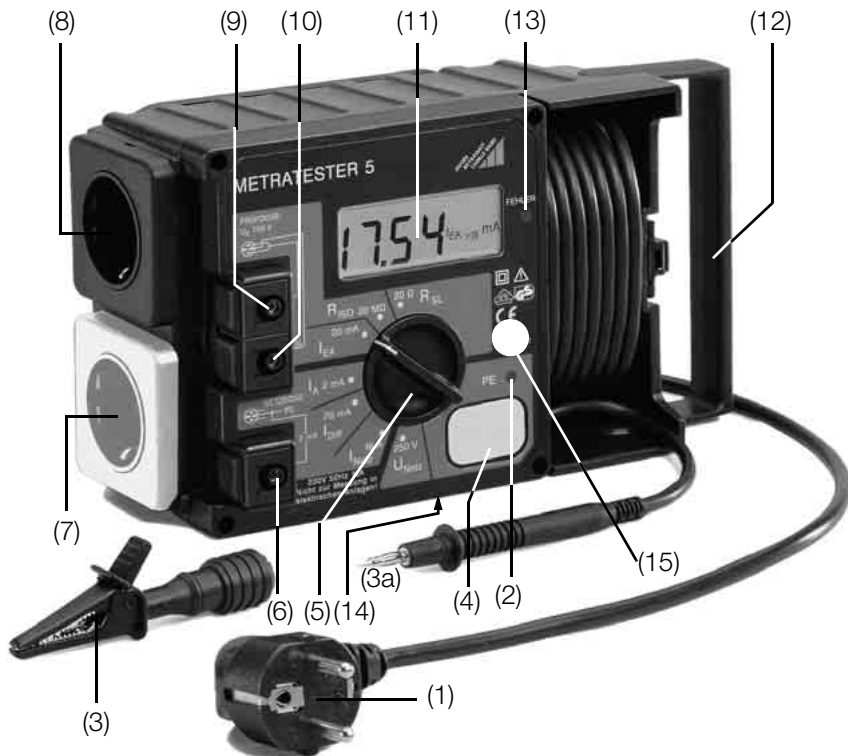

- | | |
|---|--|
| (1) Mains plug
(take-up spool at back of housing
for mains cable) | (6) Connector jack/terminal for testing for
the absence of voltage at conductive
parts at the DUT per DIN VDE 0701
Part 240 |
| (2) Signal lamp PE for testing the
mains protective conductor | (7) Mains outlet |
| (3) Alligator clips for attachment
to the test probe (3a) | (8) Test socket |
| (3a) Test probe | (9) Connector jack/terminal for DUT
phase conductors (wired parallel
to the socket) |
| (4) Contacting surface for contact finger | (10) Connector jack/terminal for DUT
protective conductor (wired parallel
to test socket) |
| (5) Measuring function selector switch
R _{SL} Protective Conductor Resistance
R _{ISO} Insulation Resistance
I _{EA} Equivalent Leakage Current
I _A Contact or Leakage Current
(for confirmation of absence of voltage)
I _{Diff} Residual Current
I _{Netz} Load current at mains outlet
U _{Netz} Mains Voltage | (11) LCD display (description see page 28) |
| | (12) Carrying handle |
| | (13) Error lamp |
| | (14) Infrared interface |
| | (15) Transmission key
(METRATESTER®5-F only) |

METRATERESTER®5/5-F Display

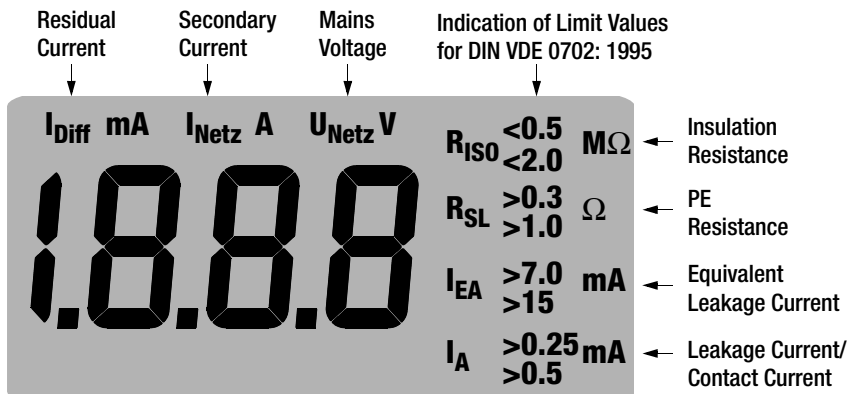

Display text subject to change without notice.

KS 13 Accessory Cable Set



Contents

	Page
1 Safety Features and Precautions	5
2 Applications	6
3 Operating and Display Elements	6
3.1 Error and Limit Value Messages	7
4 Mains Connection	8
4.1 Connecting the Tester	8
4.2 Testing Protective Conductor Potential	9
4.3 Measuring Mains Voltage	9
4.4 Connecting the Device Under Test to the Test Instrument	10
4.4.1 Safety Class I DUT with Mains Plug	10
4.4.2 Safety Class II DUT	10
4.4.3 DUT Without Mains Plug or Safety Class III DUT	10
4.4.4 3-Phase DUT	10
4.5 General Measuring Procedures	11
4.6 Residual Current Monitoring	11

5	Testing Devices per DIN VDE 0701, Part 1: 2000	12
5.1	General	12
5.2	Visual Inspection	14
5.3	Measuring Protective Conductor Resistance	14
5.4	Measuring Insulation Resistance	15
5.5	Measuring Equivalent Leakage Current	15
5.6	Leakage Current Measurement	16
5.6.1	Measuring Contact Current	16
5.6.2	Measuring Residual Current	16
6	Testing Devices per DIN VDE 0702:1995	17
6.1	General	17
6.2	Measuring Protective Conductor Resistance	17
6.3	Measuring Insulation Resistance	18
6.4	Measuring Equivalent Leakage Current	19
6.5	Measuring Contact Current	19
6.6	Measuring Residual Current	19
7	Testing Data Processing Systems and Office Machines per DIN VDE 0701, Part 240	20
7.1	General	20
7.2	Visual Inspection	20
7.3	Protective Conductor Test	20
7.4	Testing for the Absence of Voltage at User Accessible, Exposed Conductive Parts	22
8	Measuring Load Current from the Mains Outlet	23
9	METRATESTER[®] 5 Infrared Interface	24
10	METRATESTER[®] 5-F Radio Interface	25
10.1	Applications	25
10.2	Initial Start-Up	25
10.3	Using the Radio Interface	25
10.4	Radio Interface Characteristic Values	25
11	Technical Data	27
12	Maintenance	29
13	Repair and Replacement Parts Service DKD Calibration Lab and Rental Instrument Service	30
14	Product Support	31

1 Safety Features and Precautions

The tester is manufactured and tested in accordance with the following standards:

IEC/EN 61010-1/

VDE 0411-1

Safety regulations for electrical measuring, control, regulating and laboratory devices – general requirements

and

DIN VDE 0404-1:2002-05

Devices for the technical safety inspection of electrical equipment; Part 1: general requirements, and Part 2: periodic device testing

When used for its intended purpose, the safety of the user, the test instrument and the device under test (electrical equipment) is assured.

Read the operating instructions carefully and completely before placing your test instrument into service, and follow all instructions contained therein. Make sure that the operating instructions are available to all users of the instrument.

The tests may only be conducted under the supervision of a qualified electrician. The user must be instructed by a qualified electrician in the performance and evaluation of the test.

Observe the following safety precautions:

- The device may only be connected to a mains outlet rated at 230 V which is protected with a fuse or circuit breaker rated at max. 16A.
- No measurements within electrical systems are allowed.
- Be prepared for the occurrence of unexpected voltages at devices under test. For example, capacitors may be dangerously charged.
- Make certain that connector cables are not damaged, e.g. damaged insulation, interruptions etc.



Attention!

Devices under test may only be connected to the mains outlet after they have successfully completed safety testing in accordance with DIN VDE 0701 or DIN VDE 702!

Repair, Parts Replacement and Balancing

Voltage conducting parts may be exposed when the device is opened. The device must be disconnected from all sources of voltage before repair, replacement of parts or balancing. If repair or balancing of an open, live device cannot be avoided, this may only be performed by trained personnel who are familiar with the dangers involved.

Errors and Extraordinary Strains

If it may be assumed that the device can no longer be operated safely, it must be removed from service and secured against unintentional use. Safe use can no longer be relied upon,

- if the device demonstrates visible damage,
- if the device no longer functions,
- after lengthy periods of storage under unfavorable conditions.

Approvals



Branding of the METRATESTER®5/5-F testers with the VDE GS mark has been approved by VDE testing authorities.

2 Applications

The tester is intended for the testing and measurement of repaired or modified electrical devices in accordance with DIN VDE 0701 or DIN VDE 702. These regulations require the measurement of protective conductor resistance, insulation resistance and equivalent leakage current for repaired or modified electrical devices, as well as testing for the absence of voltage at exposed, conductive parts for data processing systems and office machines.

Testing for the absence of voltage at the mains connection protective conductor and line voltage measurements can also be performed with this instrument. The device under test can be connected to mains power at the mains outlet integrated into the tester, which provides for the measurement of power consumption and the testing of functions.



Attention!

Limit values displayed at the instrument make reference to periodic testing requirements set forth in VDE 0702: 1995.

3 Operating and Display Elements

(1) Mains Plug

The tester is connected to the 230 V mains outlet with the mains plug. If no earthing contact socket is available, or if only three-phase current is available, the KS13 cable set can be used to establish a connection.

The mains connection must be fused. Maximum nominal rating: 16 A!

(2) PE Signal Lamp for Protective Conductor Testing

The PE signal lamp lights up, if a potential difference of ≥ 100 V occurs between the contacting surface (4) and the earthing contact at the mains plug (1).

(3) Alligator clip (gripper clip for attachment to the test probe)

Connect the housing of the device under test with the alligator clip for measurement of protective conductor resistance.

(4) Contacting Surface for Contact Finger

The PE signal lamp (2) lights up, if a potential difference of ≥ 100 V occurs between the PE protective conductor at the mains plug (1) and the contacting surface.

The contacting surface is electrically isolated from all terminals, as well as from the measuring circuit, and thus conforms to protection class III!

(5) Measuring Function Selector Switch

Measuring functions can be selected with the function selector switch. Displayed values at intermediate switch positions have no significance.

(6) Connector Jack/Terminal for Measurement of Contact Current at Conductive Components at the Device Under Test

This terminal is intended for the measurement of contact current at exposed conductive parts which are not connected to the protective conductor (see chapter 7.4, page 22).

(7) Mains Outlet

The DUT can be connected to the integrated mains outlet for the measurement of power consumption and functions testing.

Residual current measurement is performed in this way as well.

Overcurrent protection is provided by the mains fuse or circuit breaker, see (1).

(8) Test Socket

The DUT is connected to the test socket for the measurement of protective conductor resistance, insulation resistance and equivalent leakage current in accordance with DIN VDE 0701 and DIN VDE 0702, if the DUT is equipped with a mains plug.

(9) Connector Jack/Terminal for DUT Phase Conductors

This terminal is wired in parallel to the two short-circuited phase conductor terminals at the test socket (8). The DUT phase conductors can be connected to this jack/terminal, if the DUT is not equipped with a mains plug.

(10) Connector Jack/Terminal for DUT Protective Conductor

This terminal is wired in parallel to the protective conductor terminal at the test socket (8). The DUT protective conductor can be connected to this jack/terminal, if the DUT is not equipped with an earthing contact plug. Beyond this, exposed conductive parts at the device under test must be connected to this jack for insulation testing and the measurement of equivalent leakage current.

(11) LCD Display

Measured values are displayed in digital form at the LCD.

(12) Carrying Handle

The carrying handle can be folded out.

(13) Error Lamp

The red error lamp indicates that limit values have been exceeded during the measurement of protective conductor and insulation resistance, equivalent leakage, contact and leakage current, as well as residual current. The limit values apply for periodic testing in accordance with DIN VDE 0702:1995.

KS 13 Accessory Cable Set

The KS 13 cable set consists of an adapter socket with three permanently connected cables, 3 measurement cables, 3 plug-on pick-off clips and 2 plug-on test probes. With the KS 13 the tester and the DUT can be connected, even if no earthing contact socket is available for the mains connection, or no earthing contact plug is present at the DUT.

3.1 Error and Limit Value Messages

Error Message	Condition	PE Signal Lamp
Protective conductor potential, at mains	$U_B \geq 25 \text{ V}$	If contact surface is contacted

The following limit values apply for DIN VDE 0702: 1995

Error Messages	Condition	Red Error Lamp Continuously Lit	Limit Values are Displayed	Continuous Acoustic Signal
Protective conductor resistance	$R_{SL} > 0.3 \Omega$	•	•	—
	$R_{SL} > 1 \Omega$	•	•	•
Insulation resistance	$R_{ISO} < 0.5 \text{ M}\Omega$	•	•	•
	$R_{ISO} < 2.0 \text{ M}\Omega$	•	•	—
Equivalent leakage current	$I_{EA} > 7.0 \text{ mA}$	•	•	—
	$I_{EA} > 15 \text{ mA}$	•	•	•
Leakage current / contact current (substantiation of absence of voltage)	$I_A > 0.25 \text{ mA}$	•	•	—
	$I_A > 0.5 \text{ mA}$	•	•	•
Residual current	$I_{Diff} \geq 3.5 \text{ mA}$	•	—	•

Residual Current Limit Value Violations

The METRATESTER[®] 5/5-F is equipped with a **selector switch independent, residual current monitoring** function. If the red error lamp lights up and no message regarding a limit value violation appears at the display, residual current at the mains outlet is dangerously high – regardless of the selector switch setting. If this is the case, it is advisable to measure residual current (differential current) by turning the selector switch to the “I_{DIFF}” position.

Only the displayed numeric value should be considered when **evaluating residual current** with the selector switch in the “I_{DIFF}” position. The error lamp may be caused to light up as a result of residual current monitoring for values of as low as approximately 3.2 mA. The error lamp lights up in any case as of 3.5 mA.

4 Mains Connection

4.1 Connecting the Tester

- Connect the tester to the 230 V mains with the mains plug (1). If no earthing contact socket is available, or if only a three-phase socket is available, connection of the phase conductors, the neutral conductor and the PE conductor can be accomplished with the help of the adapter socket. It includes 3 permanently connected cables and is included with the KS 13 accessory cable set.

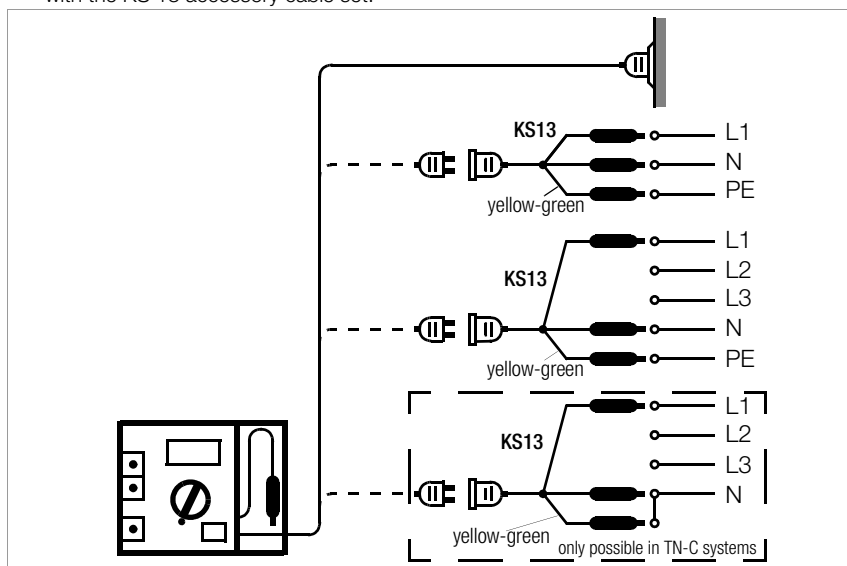

Attention!

The mains connection must be fused! The fuse may not exceed a rating of 16 A! The pick-off clips on the cables at the adapter socket may only be connected in the voltage-free condition!

If mains voltage is present, characters are displayed at the LCD regardless of the position of the function selector switch, even if no DUT has been connected. Thus the presence of characters at the display indicates the presence of voltage – independent of function selector switch position.

The mains voltage value is indicated at the display in the “U_{Netz} 250 V” selector switch position. In all other switch detent positions, characters are displayed which have no correlation to a measured value, if a DUT has not been connected.

4.2 Testing Protective Conductor Potential

- ◇ Bring the contact finger into contact with the contacting surface (4) and, at the same time, with a grounded object (e.g. a water pipe).
The PE signal lamp (2) must not light up! Potential between the mains plug protective conductor (1) and the contacting surface (4) is then ≤ 100 V.



Note!

The PE signal lamp (2) does not light up, if no mains voltage is present between L and N at the mains plug (1), or if L and PE are reversed at the mains connection. If, after having connected the DUT in accordance with chapter 4.1, page 8, you determine, that no characters are displayed at the LCD, the mains connection should first be inspected – e.g. with the PROFITEST®0100S-II tester.

However, if the PE signal lamp (2) lights up when contact is made with the contacting surface (4), potential between the protective conductor at the mains plug (1) and the contacting surface (4) is ≥ 25 V, i.e. voltage is present at the protective conductor.



Note!

Stray voltages may occur due to handling of the DUT, which cause the PE signal lamp (2) to light up. For example, this may occur if a device is held in the hand which has been connected to the test socket (8) due to the resultant occurrence of a capacitive voltage divider. Touch a grounded object as described above in this case.



Attention!

If testing of protective conductor potential indicates that **voltage is present at the mains protective conductor, no measurements may be performed with the tester**. In such a case voltage is also present at the exposed earthing contacts of the mains outlet (7) and at the jack (6), which may represent a hazard for the user. Immediately disconnect the tester from the mains and arrange for the correction of the mains connection error. Voltage at the mains protective conductor also distorts measured values for the following tests:

- Measurement of contact current per DIN VDE 0701:2000 or DIN VDE 0702:1995
- Absence of voltage per DIN VDE 0701-240:1986 (chapter 7.4, page 22)
- Residual current measurement

4.3 Measuring Mains Voltage

- ◇ Set the function selector switch to “ $U_{\text{Netz}} 250$ V”
- ◇ Read the measured value at the LCD.
Mains voltage must lie within the allowable range of 207 to 253 V.

4.4 Connecting the Device Under Test to the Test Instrument

The DUT must be connected to the test socket (8), or to the jacks or terminals (9 and 10) which are connected in parallel to the test socket for the measurement of **protective conductor resistance**, **insulation resistance** and **equivalent leakage current**. Terminal (9) is connected to the short-circuited phase conductor jacks at the test socket (8), and terminal (10) is connected to the earthing contact at the test socket (8). Use one of the following test setups, depending upon the type of device under test.

4.4.1 Safety Class I DUT with Mains Plug

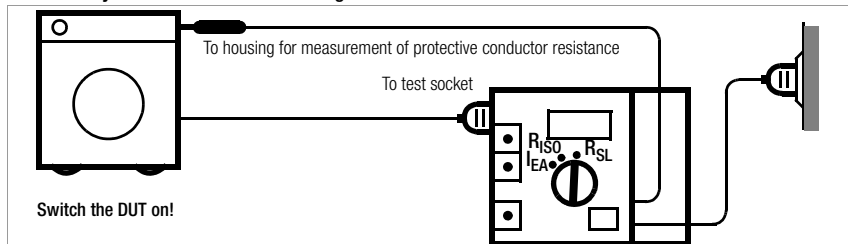

4.4.2 Safety Class II DUT

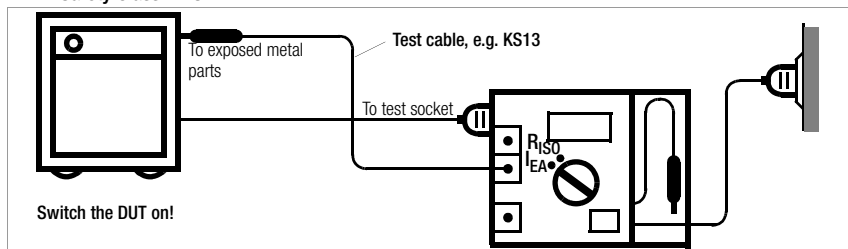

4.4.3 DUT Without Mains Plug or Safety Class III DUT

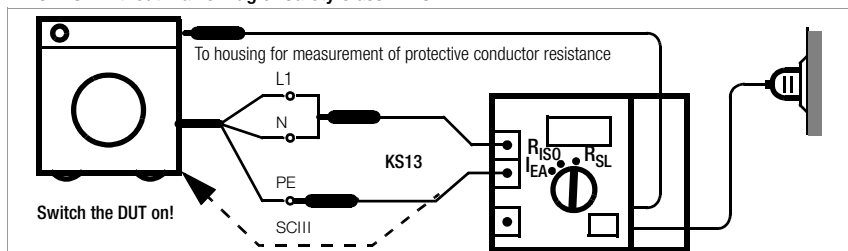

4.4.4 3-Phase DUT

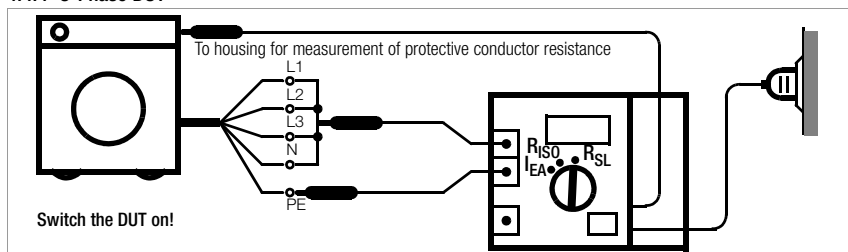

4.5 General Measuring Procedures

Line voltage must lie within the allowable range of 207 to 253 V for all of the following measurements. This assures that the accuracy of displayed measured values corresponds with the values specified under "Technical Data" (chapter 11, page 27).

Line voltage can be measured by setting the function selector switch to the "U_{Netz} 250 V" position (see chapter 4.3, page 9).

Measuring ranges for the measurement of protective conductor resistance, insulation resistance, equivalent leakage current and contact current are protected against overload in the event that interference voltages of up to 250 V are applied inadvertently.

Always start with the measurement of protective conductor resistance for safety class I devices. Insulation resistance and equivalent leakage current cannot be measured if the protective conductor does not function properly. This connection must be established externally for safety class II devices (see chapter 4.4.2).



Note!

Please note that overflow is indicated at the display during the measurement of protective conductor resistance and insulation resistance, if the terminals are open or if the upper range limit is exceeded. In this case, only the character "1" is displayed at the left-hand side of the LCD (11).



Attention!

Measuring current is reduced after approximately 10 minutes in the event of a long-term short-circuit during insulation testing. Excessive temperature is indicated at the display in this case (see chapter 11 "Display – Excessive Temp."). If this display appears, nominal current of 1 mA as required by DIN VDE 0413 and DIN VDE 0701 is no longer assured. After the short-circuit has been eliminated, and after a brief cool-down period, the message is cleared from the display and subsequent measurements once again fulfill VDE requirements.

Evaluating Measured Values

In order to make absolutely sure that limit values for insulation resistance are not fallen short of, instrument measuring error must be taken into consideration. Minimum required display values for insulation resistance can be taken from the following table. These values take maximum instrument error into consideration (under nominal conditions of use). The indicated values correspond to the required limit values (DIN VDE 0413, part 1). Intermediate values can be interpolated.

Limit Value MΩ	Minimum Display Value, METRATESTER [®] 5/5-F
0.25	0.33
0.3	0.38
0.5	0.60
1.0	1.15
2.0	2.25
7.0	7.75
10.0	11.05

4.6 Residual Current Monitoring

For your safety, residual current at the DUT connected to the mains outlet is continuously monitored by METRATESTER[®] 5/5-F instruments. If residual current reaches a value of greater than 3.5 mA, danger is indicated by means of a continuous acoustic signal.

Automatic shutdown does not occur (see chapter 3.1, page 7).

5 Testing Devices per DIN VDE 0701, Part 1: 2000

The limit values specified in the following chapters correspond to current revision levels of official standards at the time of going to print. Please note that normative legislation is continuously updated to meet the safety requirements necessitated by changing market situations, and that the listed limit values are thus subject to change. Please contact our update service department in order to adapt test instruments to new standards.

5.1 General

According to DIN VDE 0701, part 1, edition 2000, repaired or modified electrical devices must provide users with the same protection against electrical energy as is offered by new devices. The following tests must be performed to this end, in the order indicated:

- 1 Visual inspection
- 2 Protective conductor resistance
- 3 Insulating characteristics:
if technically sensible, i.e. if the DUT does not include any all-pole, electrically actuated switches:
 - Insulation resistance followed by protective conductor current or equivalent leakage current
 - Other: leakage current during operation (protective conductor current and contact current), safety extra-low voltage (only at connecting points for safety extra-low voltage generated within the device under test)
- 4 Function test
- 5 Labelling inspection
- 6 Documentation



Note!

An RCCB may be tripped if measurement is performed at a defective device!

Changes to DIN VDE 0701-1: 1993

- The standard has been completely revised as regards both layout and technical aspects.
- Test procedures have been adopted for devices whose insulation characteristics cannot be fully evaluated before initial start-up.
- The limit values for protective conductor resistance and insulation testing have been re-specified.
- Device-specific supplements in parts 10 through 13 and 260 have been integrated by means of device-specific appendices E through H in part 1.
- In order to substantiate the insulation characteristics of the device under test, **measurement of leakage current with line voltage** has been additionally prescribed. This represents a stiffening of previous stipulations, which takes the ever increasing percentage of devices with capacitive circuitry into consideration.
- **Protective conductor resistance values** have been aligned to DIN VDE 0702.
The limit value is:
 - 0.3 Ω (for up to 5 meters) plus 0.1 Ω for each additional 7.5 meters.
- The protective conductor for safety class I hand-held electric tools can now be tested with minimal test currents as well.

- **Insulation resistance** for safety class I has been redefined to 1 M Ω , and to 0.3 M Ω for devices with heating elements. This test is required for all devices for which all charged insulation is monitored during testing (practically all devices without electrically actuated, all-pole relays).

The limit values are:

- Safety class I devices under test: 1 M Ω
- Safety class I DUTs with heating elements: 0.3 M Ω
- Safety class II devices under test: 2 M Ω
- Safety class III devices under test: 0.25 M Ω
- Test voltage (to 0.5 M Ω): 500 V

The limit value for equivalent leakage current has been adapted to the limit value for protective conductor current. As opposed to the 1993 version of the regulation, the insulation test must be passed. Measurement of protective conductor current, by means of either the residual current method or measurement of equivalent leakage current, must always be performed and passed after insulation resistance measurement.

- **Equivalent Leakage Current**

This test must be performed after insulation testing has been passed. The measured value must be corrected such that it corresponds to the measured value which would result at line voltage. The METRATESTER[®] performs this function electronically.

The limit values are:

- 3.5 mA for safety class I devices whose exposed conductive parts are all connected to the protective conductor
- 0.5 mA for devices with exposed conductive parts which are not connected to the protective conductor

- **Protective Conductor Current**

This test is required for all safety class I devices for which insulation resistance cannot be measured, and for which all exposed conductive parts are connected to the protective conductor. If non-polarized mains plugs are used, the test must be performed with the mains plug poled in both directions.

The following test methods are permissible:

- **Direct method** if the device under test is set up under insulated conditions
- **Residual current method** for cases where data transmission cables and gas and water supply lines cannot be disconnected

Regardless of the test method, the limit values are:

- 1 mA/kW for devices under test with heating elements and a connected load of greater than 3.5 kW
- 3.5 mA for all other devices under test

- **Contact Current**

This test is required for all devices whose insulation resistance cannot be measured, and which include exposed conductive parts which are not connected to the protective conductor. If non-polarized mains plugs are used, the test must be performed with the mains plug poled in both directions.

The following test methods are permissible:

- **Direct method** if the device under test is set up under insulated conditions
- **Residual current method**, only possible if no protective conductor is present

The limit value is 0.5 mA for both measuring methods.

5.2 Visual Inspection

Visual inspection is performed prior to measurements with the test instrument.

Visual inspection includes:

- Housing and protective covers
- Connections and external cables including fasteners and plugs
- Visible condition of insulation material
- Strain reliefs for cables, anti-kink devices and cable routing
- Fuse links which are accessible to the user (including labeling and inspection of fuse ratings)
- Cooling vents and air filters
- Pressure relief valves
- Safety relevant labelling

5.3 Measuring Protective Conductor Resistance

The measurement of protective conductor resistance is of course not possible for devices which are not equipped with a protective conductor (e.g. safety class II and III devices).

- Connect the device under test as described in chapter 4.4, page 10.
- Set the function selector switch to the "R_{SL} 20 Ω" position.
- Read the measured value in "Ω" from the LCD.
- Move the cable from the DUT during the measurement, section by section over its entire length, in order to locate interruptions.

Protective conductor resistance may not exceed the following values:

Maximum Allowable Protective Conductor Resistance Values Depending upon Cable Length

Length to [m]	5	12.5	20	27.5	35	42.5	50	more than 50
Max. resistance [Ω]	0.3	0.4	0.5	0.6	0.7	0.8	0.9	1.0

Under no circumstances may a value of 1 Ω be exceeded. The table is also valid for cable reels and extension cables.



Attention!

The alligator clip (3) must make good contact with the housing of the device under test!

The connector cable must be moved during measurement, section by section over its entire length – for permanently installed devices only in so far as the cable is accessible during repair, modification or testing. If the resistance value fluctuates during this manual test which is essential for continuity testing, it must be assumed that the protective conductor is damaged, or that one of its connection points is defective. Defects of this type must be corrected before any further tests are performed.

5.4 Measuring Insulation Resistance

This measurement may only be performed if the device under test has successfully completed protective conductor resistance testing. This measurement may not be performed if all-pole electrically actuated switches are included in the device under test.

- Connect the device under test as described in chapter 4.4, page 10.
Make sure that the jack (10) is connected to exposed conductive parts at the DUT for safety class II and III devices.
- Set the function selector switch to the “ $R_{ISO} 20 M\Omega$ ” range.
- Activate all functions of the DUT, and be certain, for example, that contacts for temperature sensitive switches and the like are also closed.
- Read the measured value in “ $M\Omega$ ” from the LCD (11).
Insulation resistance may not fall short of the following values:

The following limit values for insulation resistance may not be fallen short of:

Device Type	Limit Value	Minimum Display Value
Safety class I devices	1 $M\Omega$	1.15 $M\Omega$
Safety class I devices with heating elements	0.3 $M\Omega$	0.38 $M\Omega$
Safety class II devices	2.0 $M\Omega$	2.25 $M\Omega$
Safety class III devices and battery powered devices	1000 Ω/V or 250 $k\Omega$	

5.5 Measuring Equivalent Leakage Current

According to DIN VDE 0701:2000, it is absolutely essential to measure protective conductor current after insulation resistance measurement has been performed. We recommend the use of an equivalent leakage current measurement.

- Connection is the same as shown for the measurement of insulation resistance (see chapter 5.4, page 15).
- Set the function selector switch to the “ $I_{EA} 20 mA$ ” position.
- Switch all DUT functions on and make sure, for example, that all contacts for temperature sensitive switches and the like are closed.
- Read the measured value in “mA” from the LCD.
According to DIN VDE 0701:2000, the displayed value for current between components to which voltage is applied during operation and exposed metal parts may not exceed 3.5 mA, or 1 mA/kW for devices with heating power of greater than 3.5 kW.

5.6 Leakage Current Measurement

Frequency response is taken into consideration in accordance with the graph to the right during leakage current measurement.

5.6.1 Measuring Contact Current

Contact current measurement can be performed instead of insulation resistance measurement for class II devices, or for class I devices with exposed conductive parts which are not connected to the protective conductor.

- Connect the device under test to the mains outlet.

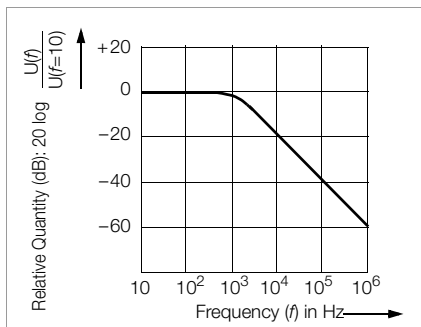

Attention!

The protective conductor test must first be performed and passed.

- Connect the cable with the test probe to the “2 mA” jack.
- Set the function selector switch to the “I_A 2 mA” position.
- Start up the device under test.
- Contact all exposed metal parts at the device under test with the test probe.
- Read the residual current value in mA from the display. This value may not exceed 0.5 mA.

Measurements must be performed with the mains plug poled in both directions. The larger of the two measured values applies.



Note!

If no device under test is connected, random characters appear at the digital display which may not be construed as measured values.

5.6.2 Measuring Residual Current

Residual current (differential current) is measured between phase conductor L and neutral conductor N at the device under test. This measurement may not be performed until the protective conductor test has been passed (see chapter 5.3, page 14).

- Connect the device under test to the mains outlet.
- Set the function selector switch to the “I_{Diff} 20 mA” position.
- Start up the device under test.
- Read the residual current value in mA from the display. According to DIN VDE 0701:2000, the displayed current value may not exceed 3.5 mA, or 1 mA/kW for devices with heating power equal to or greater than 3.5 kW.

Measurements must be performed with the mains plug poled in both directions. The larger of the two measured values applies.



Note!

If no device under test is connected, random characters appear at the digital display which may not be construed as measured values.



Note!

If the METRATESTER®5/5-F is integrated into a 3-phase ammeter, residual current is measured as the sum of instantaneous current in conductors L1, L2, L3 and N.

6 Testing Devices per DIN VDE 0702:1995

6.1 General

The following periodic tests are required according to DIN VDE 0702:

- Protective conductor resistance measurement
- Insulation resistance measurement
- Equivalent leakage current
- Contact current measurement
- Residual current measurement



Note!

If any doubts exist concerning the performance of an insulation resistance measurement, a differential current measurement can be performed in its place. For example, this may be the case with electronic devices and data processing equipment, or safety class I devices if it is assured that all components which are charged with line voltage are covered by this measurement.

This measurement may only be performed after the protective conductor at the DUT has been tested.

The device under test must be plugged into the **mains outlet** at the METRATESTER®5/5-F test instrument for measurement of residual current.



Note!

An RCCB may be tripped if measurement is performed at a defective device!

6.2 Measuring Protective Conductor Resistance

The measurement of protective conductor resistance is of course not possible for devices which are not equipped with a protective conductor (e.g. safety class II and III devices).

- ◇ Connect the device under test as described in chapter 4.4, page 10.
- ◇ Set the function selector switch to the " $R_{SL} 20 \Omega$ " position.
- ◇ Read the measured value in " Ω " from the LCD.
- ◇ Move the cable at the DUT during the measurement, section by section over its entire length, in order to locate interruptions.

Protective conductor resistance may not exceed the following values:

Maximum Allowable Protective Conductor Resistance Values Depending upon Cable Length

Length to [m]	5	12.5	20	27.5	35	42.5	50	more than 50
Max. resistance [Ω]	0.3	0.4	0.5	0.6	0.7	0.8	0.9	1.0

The table is also valid for cable reels and extension cables. The following applies to longer cable lengths: additional 0.1 Ω per additional 7.50 m cable length, no maximum length limit, independent of conductor cross-section.



Attention!

The alligator clip (3) must make good contact with the housing of the device under test!

The connector cable must be moved during measurement, section by section over its entire length – for permanently installed devices only in so far as the cable is accessible during repair, modification or testing. If the resistance value fluctuates during this manual test which is essential for continuity testing, it must be assumed that the protective conductor is damaged, or that one of its connection points is defective.

Defects of this type must be corrected before any further tests are performed.

6.3 Measuring Insulation Resistance

This measurement may only be performed if the device under test has successfully completed protective conductor resistance testing. This measurement may not be performed if all-pole electrically actuated switches are included in the device under test.

➤ Connect the device under test as described in chapter 4.4, page 10.

Make sure that the jack (10) is connected to exposed conductive parts at the DUT for safety class II and III devices.

➤ Set the function selector switch to the “R_{ISO} 20 MΩ” range.

➤ Switch all DUT functions on and make sure, for example, that all contacts for temperature sensitive switches and the like are closed.

➤ Read the measured value in “MΩ” from the LCD (11).

Insulation resistance may not fall short of the following values:

The following limit values for insulation resistance may not be fallen short of:

Device Type	Limit Value	Minimum Display Value
Safety class I devices	0.5 MΩ	0.60 MΩ
Safety class I devices with heating elements	0.5 MΩ ¹⁾	0.60 MΩ
Safety class II devices	2.0 MΩ	2.25 MΩ
Safety class III devices or battery powered devices	1000 Ω/V or 250 kΩ	

¹⁾ Equivalent leakage current measurement must be performed if the applicable limit value is fallen short of.



Attention!

If a value of 0.5 MΩ is fallen short of for safety class I devices with heating elements, equivalent leakage current measurement must be performed and passed in accordance with chapter 6.4, page 19.

Each exposed conductive part must be contacted with the test probe connected to the jack (10), and insulation resistance must be measured for safety class II and III devices, and battery powered devices.

No insulation resistance measurement is required for safety class III devices, or for battery powered devices which fulfill both of the following conditions:

- Nominal power ≤ 20 VA
- Nominal voltage ≤ 42 V.

Batteries must be disconnected during the performance of measurements at battery powered devices.

6.4 Measuring Equivalent Leakage Current

According to DIN VDE 0702:1995, equivalent leakage current must be measured for safety class I devices:

- for which interference suppression capacitors have been installed or replaced during the course of repair or modification.
- which are equipped with heating elements and for which an insulation resistance of less than $0.5\text{ M}\Omega$ has been measured (chapter 6.3, page 18).
- Connection of the DUT is the same as for insulation resistance measurement (see chapter 5.4, page 15).
- Set the function selector switch to the “ $I_{EA}\ 20\text{ mA}$ ” position.
- Switch all DUT functions on and make sure, for example, that all contacts for temperature sensitive switches and the like are closed.
- Read the measured value in “mA” from the LCD.
According to DIN VDE 0702, the displayed value for current between components to which voltage is applied during operation and exposed metal parts may not exceed 7 mA, or 15 mA for devices with heating power of greater than or equal to 6 kW.

6.5 Measuring Contact Current

Contact current measurement can be performed instead of insulation resistance measurement for class II devices, or for class I devices with exposed conductive parts which are not connected to the protective conductor.

- Connect the device under test to the mains outlet.



Attention!

The protective conductor test must first be performed and passed.

- Connect the cable with the test probe to the “2 mA” jack.
- Start up the device under test.
- Contact all exposed metal parts at the device under test with the test probe.
- Read the residual current value in mA from the display. This value may not exceed 0.5 mA.

Measurements must be performed with the mains plug poled in both directions. The larger of the two measured values applies.



Note!

If no device under test is connected, random characters appear at the digital display which may not be construed as measured values.

6.6 Measuring Residual Current

Residual current (differential current) is measured between phase conductor L and neutral conductor N at the device under test. This measurement may not be performed until the protective conductor test has been passed (see chapter 5.3, page 14).

- Connect the device under test to the mains outlet.
- Set the function selector switch to the I_{Diff} position.
- Start up the device under test.
- Read the residual current value in mA from the display. According to DIN VDE 0701:2000, the displayed current value may not exceed 3.5 mA.

Measurements must be performed with the mains plug poled in both directions. The larger of the two measured values applies.

7 Testing Data Processing Systems and Office Machines per DIN VDE 0701, Part 240

7.1 General

The following safety relevant tests are required for data processing systems by this regulation:

- Visual inspection
- Protective conductor test
- Testing for the absence of voltage at user accessible, exposed conductive parts

7.2 Visual Inspection

Visual inspection is performed as described in chapter 5.2, page 14.

7.3 Protective Conductor Test

Resistance is measured between the earthing contact at the mains plug and all exposed conductive parts which might become charged with voltage in the event of an error for individual devices with a mains plug.

- Connect the device under test (individual device) to the mains outlet.

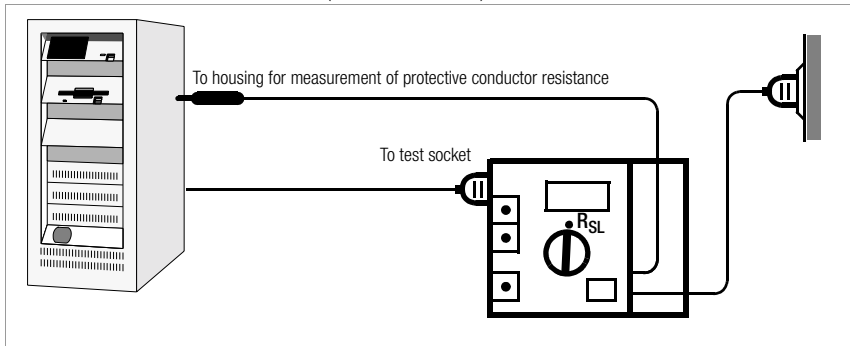

- Set the function selector switch to the "20 Ω R_{SL}" position.
- Read the measured value in " Ω " from the LCD.
Protective conductor resistance may not exceed 0.3 Ω . Protective conductor resistance may not exceed 1 Ω for permanently installed data processing systems.
- Move the cable at the DUT during the measurement, section by section over its entire length, in order to locate interruptions. If the resistance value fluctuates during this manual test, it must be assumed that the protective conductor is damaged, or that one of its connection points is defective.

A resistance value of up to 1Ω measured between a suitable earthing contact and all exposed conductive parts which might become charged with voltage in the event of an error is allowable for permanently installed devices.

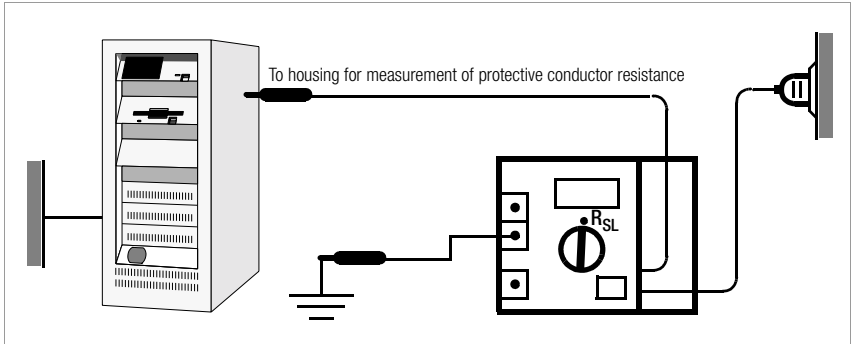

In the case of data processing systems or combinations of permanently installed individual devices, the network should be decoupled and individual measurements should be performed. If decoupling is not feasible, individual measurements at interconnected devices may not demonstrate differences of greater than 0.2Ω from device to device. If this differential value is exceeded, separate, individual measurements are then required for each device within the network.

7.4 Testing for the Absence of Voltage at User Accessible, Exposed Conductive Parts

According to DIN VDE 0701, part 240, all exposed conductive parts must be tested for the absence of voltage after maintenance, repair or modification of data processing equipment and office machines.

This applies to:

- Safety class I devices for user accessible, exposed conductive parts which are not connected to the protective conductor
- Safety class II devices (totally insulated appliances) for all user accessible, exposed conductive parts

with the mains plug poled in both directions.

- ↻ Connect the test instrument to a separate mains outlet parallel to the device under test. The mains outlets to which the test instrument and the DUT are connected must be connected to the same protective conductor system. The device under test must be operated at the mains for the entire duration of the measurement. The device under test can also be connected to the mains outlet at the test instrument (7).

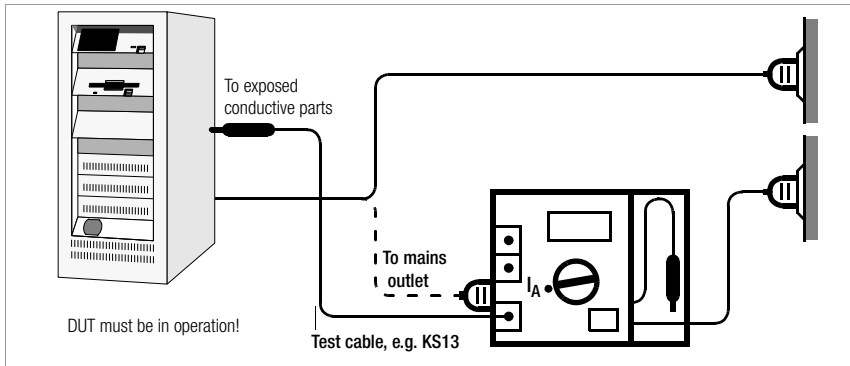

Attention!

The data processing system or office machine must be disconnected from supply power in order to perform testing for the absence of voltage with the mains plug poled in both directions. However, the mains plug may only be pulled with approval from the responsible party!

A defect in the device under test may cause tripping of the residual current circuit breaker during testing, which would also result in interruption of supply power.

Data must be backed up before measurements are performed at data processing equipment!

The manufacturer of the test instrument assumes no liability for loss of data or other damages which result from use of the test instrument.

- ↻ Switch all DUT functions on.
- ↻ Set the function selector switch to the "I_A 2 mA" position.
- ↻ Connect a measurement cable with test probe to the jack/terminal (6) and contact all exposed conductive parts at the device under test, or all exposed conductive parts which are not connected to the protective conductor for safety class I devices.
- ↻ Read each measured value in "mA" from the LCD. According to DIN VDE 0701, part 240, these measured values may not exceed 0.25 mA.

8 Measuring Load Current from the Mains Outlet

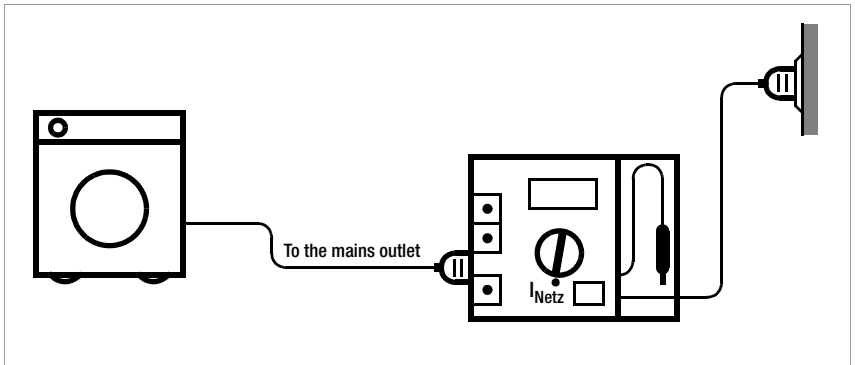

Attention!

The device under test may not be connected to the mains outlet (7) until it has passed safety testing in accordance with DIN VDE 0701, part 1!

- Connect the earthing contact plug from the device under test to the mains outlet (7).
 - Set the function selector switch to the "I_{Netz} 16 A" position.
 - Switch the device under test on.
 - Read the measured value in "A" from the LCD (11).
-



Attention!

Maximum allowable load capacity is 16 A continuous and 20 A for up to 10 minutes. The electrical system to which the test instrument is connected must be protected against overload with a fuse or circuit breaker. The fuse or circuit breaker rating may not exceed 16 A!

“IRDA” Message

Type	infrared interface (in compliance with IRDA per HP Design Guide)
Format	9600 baud, 1 start bit, 8 data bits, 1 stop bit, no parity, no xon/xoff, no handshake
Content	device ID, measured value, measuring range, alarm messages: error per SK I and SK II
Transmission Speed	2.5 times per second, corresponds to measuring speed

Message

Alarm Messages:
 30h = error-free
 31h = protection class I error *
 32h = protection class II error *

Carriage Return=0Dh
 Line Feed=0Ah

Mtr51234SDCC_rLF

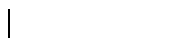

ASCII characters
Device Name



ASCII characters
Meas. Value (amount)
 overflow=9999



Measuring Range
 Switch code:
 0011 0001B=250 V
 0011 0010B=16 A
 0011 0011B=empty
 0011 0100B=l-diff
 0011 0101B=2 mA
 0011 0110B=empty
 0011 0111B=l-EA
 0011 1000B=20 MΩ
 0011 0000B=20 Ω



Check Sum
 via "Ird a error" [and],
 0000 1111B plus 30 hex

Check Sum
 via "Ird a error" [and],
 1111 0000B plus 30 hex

* For the differentiation of errors which cannot be assigned to various protection classes, 31h is the more severe error!

10 METRATESTER[®]5-F Radio Interface

10.1 Applications

The radio interface at the METRATESTER[®]5-F test instrument allows for the wireless transmission of measurement results to a PC.

The test instrument's transmitter sends measurement data to a receiver which has been linked to a PC via the RS232 interface.

This provides for various advantages:

- If the test instrument is used to perform measurements in an aggressive environment, the PC and a printer can be operated at a more appropriate location.
- On-site storage of measurement results to memory
- Documentation of test results at the customer's facility

10.2 Initial Start-Up

- ◇ Connect the receiver to the RS232 interface at the PC (PC must be switched off).
- ◇ Switch the PC on.
- ◇ Start the PC.doc-WORD or the PC.doc-ACCESS program.
- ◇ Place the METRATESTER[®]5-F test instrument into service.

10.3 Using the Radio Interface

Single Measurements

- ◇ Activate the transmission key at the test instrument after the completion of each measurement in order to transmit measurement results to the PC.

The test instrument acknowledges transmission of the data with an acoustic signal, i.e. after the third transmission of a complete data frame.

Continuous Measurement

- ◇ Press and hold the transmission key for at least 2.5 seconds.

The test instrument acknowledges activation of the continuous measurement mode while the key is depressed with an acoustic signal which is repeated three times, after which all measurements are continuously transmitted to the PC. The continuous measurement function can only be deactivated by disconnecting the test instrument from mains power.

Evaluation of Measurement Results at the PC

See PC.doc-WORD/PC.doc-ACCESS operating instructions.

10.4 Radio Interface Characteristic Values

Frequency	433.92 MHz
Mod. Type	OOK (on-off keying)
Power	
Consumption	< 10 mW
Range	max. 30 m (within a single room), Exception: Panel-mount version METRATESTER [®] 5-F-E: max. 6 m, see drawing at right

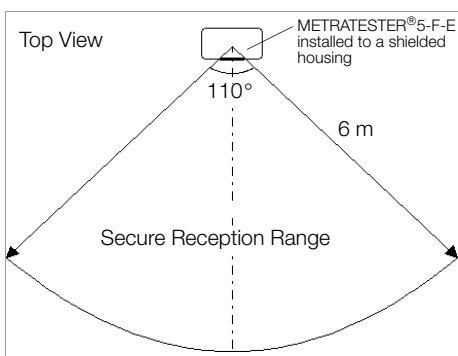

Transmission Speed	2400 baud, each frame is transmitted 3 times
Frame Format	1 start bit, 8 data bits, 1 stop bit, no parity, no xon/xoff, no handshake
Frame Content	Device ID, measured value, measuring range, measurement type

Receiver

Power Supply	9 V monobloc battery in accordance with IEC 6LR61 (alkaline-manganese). Internal battery is disconnected if power is supplied from the PC.
Supply Voltage	7 ... 12 V
Dimensions	W x H x D: 65 x 100 x 24 mm
Weight	150 gr. with battery
Connector Cable	approx. 15 cm long



Attention!

The length of the cable between the receiver and the PC may not exceed 3 meters due to EMC considerations.

RS232 Interface Connector Pin Assignments

The 9 pin Cannon connector at the receiver is configured as follows:

- 1: NC
- 2: Data to PC (receiver)
- 3: Control wire auxiliary power
- 4: NC
- 5: Ground
- 6: NC
- 7: NC
- 8: NC
- 9: Power supply from PC

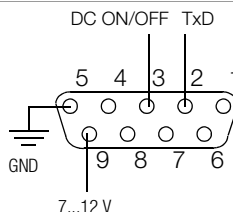

Frame

UU AXX 1234S C C_rL_F

1 Byte
Pause

2 ASCII characters for addressing the receiver
UU=55H, 55H

These characters are not included in the checksum.

ASCII Characters
Device Name

- ASCII "A" byte = 41h
- Device ID byte high byte, ASCII:
0, 1, 2, 3, 4, 5, 6, 7, 8, 9,
A, B, C, D, E, F
- Device ID byte low byte, ASCII:
0, 1, 2, 3, 4, 5, 6, 7, 8, 9,
A, B, C, D, E, F

ASCII Characters
Measurement Value
Overflow = 9999

Measuring Range
Switch code:
0011 0001B=250 V
0011 0010B=16 A
0011 0011B=open
0011 0100B=-I-Diff
0011 0101B=2 mA
0011 0110B=open
0011 0111B=-EA
0011 1000B=20 MΩ
0011 0000B=20 Ω

Checksum
ASCII for low nibble

„Carriage Return“=0Dh
„Line Feed“=0Ah

11 Technical Data

Meas. Quantity	Measuring Range	Resolution	$U_{NO-LOAD}$	R_i	I_k	I_N
PE Resistance	0 ... 19.99 Ω	10 m Ω	< 20 V –	—		> 200 mA
Insulation Resistance	0 ... 19.99 M Ω	10 k Ω	600 V –	ca. 100 k Ω	< 10 mA	> 1 mA
Equivalent Leak. Current	0 ... 19.99 mA ~	10 μ A	28 V ~	2 k Ω	< 20 mA	—
Confirmation of absence of voltage with current measurement (contact or leakage current)	0 ... 1.999 mA ~	1 μ A		2 k Ω		
Residual Current	0.01 ... 19.99 mA ~	10 μ A				

Operational Measurements

Meas. Quantity	Measuring Range	Resolution
Mains Voltage	207 ... 253 V ~	1 V
Load current at mains outlet	0 ... 16.00 A ~	10 mA

Overload Capacity

Load current at mains outlet, residual current	19 A, 5 min.
All other measuring quantities	250 V continuous

Intrinsic and Service Error

Meas. Quantity	Intrinsic Error	Service Error
Protective Conductor Resistance	$\pm (2.5 \% \text{ of rdg.} + 2 \text{ D})$	$\pm (10 \% + 5 \text{ D})$
Insulation Resistance 0 ... 19.99 M Ω	$\pm (2.5 \% \text{ of rdg.} + 2 \text{ D})$	$\pm (10 \% \text{ of rdg.} + 5 \text{ D})$
Equivalent Leakage Current	$\pm (2.5 \% \text{ of rdg.} + 2 \text{ D})$	$\pm (10 \% \text{ of rdg.} + 5 \text{ D})$
Confirmation of absence of voltage with current measurement (contact current)	$\pm (2.5 \% \text{ of rdg.} + 2 \text{ D})$	$\pm (10 \% \text{ of rdg.} + 5 \text{ D})$
Residual Current	$\pm (4 \% \text{ of rdg.} + 5 \text{ D})$	$\pm (10 \% \text{ of rdg.} + 5 \text{ D})$
Mains Voltage	$\pm (2.5 \% \text{ of rdg.} + 2 \text{ D})$	$\pm (10 \% \text{ of rdg.} + 5 \text{ D})$
Load current at mains outlet	$\pm (2.5 \% \text{ of rdg.} + 2 \text{ D})$	$\pm (10 \% \text{ of rdg.} + 5 \text{ D})$

Reference Conditions

Ambient Temperature	+23 °C \pm 2 K
Relative Humidity	40 ... 60%
Mains Voltage	230 V \pm 1 %
Measured Quantity Frequency	50 Hz \pm 0.2%
Measured Quantity Waveshape	sine (deviation between effective and rectified value \pm 0.5%)

Influence Variables and Errors

Influence Variable/ Sphere of Influence	Designation per DIN VDE 0404	Influence Errors ± ... % of measured value
Change in position	E1	—
Change in supply voltage to the test device	E2	2.5
Temperature fluctuation 0 ... 21 °C and 25 ... 40 °C	E3	Indicated influence errors per 10 K temperature change: 1 with PE resistance 0.5 all other measuring ranges
Current at device under test	E4	2.5
Low frequency magnetic fields	E5	2.5
DUT impedance	E6	2.5
Capacitance during insulation measurement	E7	2.5
Waveshape of the measured current	E8	
49 ... 51 Hz		2 with capacitive load (with equivalent leakage current)
45 ... 100 Hz		1 (with contact current)
		2,5 all other measuring ranges

Display and Signalling Devices

LCD

Display Range	0 ... 1999 digits, 3½ places
Character Height	17 mm and special characters
Overflow	indicated at display with "OL"
Excessive Temp. R_{ISO}	for long duration short-circuit: segments " R_{ISO} " and " $M\Omega$ " blink

PE Signal Lamp

Indicates whether or not voltage is present at the mains protective conductor.

Error Lamp

The red error lamp indicates that limit values have been exceeded during the measurement of protective conductor or insulation resistance, equivalent leakage, contact or leakage current, as well as residual current.

Piezoelectric Resonator

In the event that the error lamp lights up and the respectively more critical limit value is exceeded, the piezoelectric resonator also sounds.

Power Supply

Mains Voltage	230 V/50 Hz
Throughput	max. 3700 VA, dependent upon load at mains outlet

Electrical Safety

Protection Class	II
Nom. Mains Voltage	230 V
Test Voltage	Mains + PE (mains) + 2 mA socket for testing for the absence of voltage at test socket, connector jacks for phase and protective conductors and gripper clip: 3 kV~ mains to PE (mains) + 2 mA socket: 1.5 kV~
Measurement Category	II
Contamination Level	2
Safety Cut-Off	when device overheats

Electromagnetic Compatibility EMV

Product standards	EN 61326-1: 1997 EN 61326: 1997/A1: 1998
-------------------	---

Interference Emission		Class
EN 55022		A
Interference Immunity	Test value	Performance Feature
EN 61000-4-2	Contact/atmos. – 4 kV/8 kV	B
EN 61000-4-3	10 V/m	B
EN 61000-4-4	Mains connection – 2 kV	B
EN 61000-4-5	Mains connection – 1 kV	A
EN 61000-4-6	Mains connection – 3 V	B
EN 61000-4-11	0.5 period / 100%	A

Ambient Conditions

Operation	– 10 ... + 55 °C
Storage	– 25 ... + 70 °C
Atmosph. Humidity	max. 75%
Elevation	to 2000 m

Mechanical Design

Protection	Device IP 40, terminals IP 20
Dimensions	W x H x D: 190 mm x 140 mm x 95 mm
Weight	1.3 kg

12 Maintenance

No special maintenance is required. Keep outside surfaces clean and dry. Use a slightly dampened cloth for cleaning. Avoid the use of solvents, cleansers or abrasives.

13 Repair and Replacement Parts Service DKD Calibration Lab* and Rental Instrument Service

If required please contact:

GOSSEN METRAWATT GMBH
Service-Center
Thomas-Mann-Strasse 20
90471 Nürnberg, Germany
Phone +49-(0)-911-8602-0
Fax +49-(0)-911-8602-253
E-Mail service@gossenmetrawatt.com

This address is only valid in Germany.

Please contact our representatives or subsidiaries for service in other countries.

* **DKD** Calibration lab for electrical measuring quantities DKD – K – 19701

Accredited measuring quantities: Direct voltage, direct current intensity, direct current resistance, alternating voltage, alternating current intensity, alternating current active power, alternating current apparent power, direct current power, capacity, frequency

Competent Partner

GOSSEN METRAWATT GMBH is certified in accordance with DIN EN ISO 9001:2000.

Our DKD calibration laboratory is accredited by the Physikalisch Technische Bundesanstalt (*German Federal Institute of Physics and Metrology*) and the Deutscher Kalibrierdienst (*German Calibration Service*) in accordance with DIN EN ISO/IEC 17025 by under registration number DKD-K-19701.

We offer a complete range of expertise in the field of metrology: from **test reports** and **proprietary calibration certificates** right on up to **DKD calibration certificates**.

Our spectrum of offerings is rounded out with free **test equipment management**.

An on-site **DKD calibration station** is an integral part of our service department. If errors are discovered during calibration, our specialized personnel are capable of completing repairs using original replacement parts.

As a full service calibration laboratory, we can calibrate instruments from other manufacturers as well.

14 Product Support

If required please contact:

GOSSEN METRAWATT GMBH

Product Support Hotline

Phone +49-(0)-911-8602-112

Fax +49-(0)-911-8602-709

E-Mail support@gossenmetrawatt.com

Edited in Germany • Subject to change without notice • A pdf version can be found on the internet

GOSSEN METRAWATT GMBH
Thomas-Mann-Str. 16-20
90471 Nürnberg • Germany

Telefon +49-(0)-911-8602-0
Telefax +49-(0)-911-8602-669
E-Mail info@gossenmetrawatt.com
www.gossenmetrawatt.com

 **GOSSEN METRAWATT**