

Enclosure ventilation using a filter fan and exhaust filter

- Very low noise**
- Minimal mounting depth**
- Functional design**
- Time-saving installation**
- Weather and UV resistant**

Filter fans are used to provide an optimum climate in enclosures. The interior temperature of an enclosure can be reduced by channeling cooler filtered outside air into the enclosure thus expelling heated internal air. The resulting air flow prevents formation of localized heat pockets and protects the electronic components from overheating. The plastic used for the hood of this filter fan series is highly weather resistant, as well as impact and UV light resistant.



Technical Data	
Axial fan, ball bearing	service life min. 50,000 h at 77 °F (25 °C) and 65 %RH aluminum fan body, plastic rotor
Connection	2 wires w/cage clamps, AWG 14 (2.5 mm ²), length 4" (100 mm)
Housing (filter fan and exhaust filter)	Plastic, UL 94V-0, light grey
Hood (filter fan and exhaust filter)	Plastic, UL 94V-0, light grey; weather and UV light resistant according to UL 746C (f1)
Mounting frame	with double-sided industrial adhesive for mounting to the outside of enclosure; certain operating circumstances may make the additional use of screws necessary; cut-out template included
Filter media rating	G4 acc. to DIN EN 779, filtering degree 94 %
Filter material	synthetic fiber with progressive construction, temperature resistant to 212 °F, self-extinguishing class F1; moisture resistant to 100 %RH, reusable - can be cleaned by washing or vacuuming
Operating / Storage temperature	+14 to +158 °F (-10 to +70 °C) / -40 to +158 °F (-40 to 70 °C)
Protection class	I (grounded)
Protection type	IP55 (according to VDE), UL Type 1
Note: Using fine filter mat F5 increases the protection to UL Type 12 but reduces the air flow	

Special features

- The **self-adhesive seal** of the mounting frame prevents dust and water from entering the cabinet.
- **Functional design** of the intake and exhaust fan hoods very effectively prevents direct infiltration of falling water and dust. The advantage is that the filter mat does not rapidly become contaminated with dirt and therefore does not need to be exchanged as often.
- The **air channeling** makes the filter fan particularly quiet in operation.
- All filter fan models are also available with **integrated airflow monitor**.
- The **direction of air flow can easily be switched** by reversing the axial fan.
- EMC versions and other voltages are available upon request.

Part No.	Operating voltage	Air volume, free blowing	Air volume with exhaust filter	Power consumption	Average noise level (DIN EN ISO 4871)	Mounting depth	Enclosure cut-out	Weight (approx.)	Approvals
01800.0-00	AC 230 V, 50 Hz ¹⁾	12 cfm (21 m ³ /h)	9 cfm (16 m ³ /h)	13 W	31 dB (A)	1.8" (45 mm)	3.8 x 3.8"	1.3 lbs. (0.6 kg)	UL File No. E234324, VDE
01800.0-01	AC 120 V, 60 Hz	14 cfm (24 m ³ /h)	11 cfm (18 m ³ /h)	13 W	31 dB (A)	1.8" (45 mm)	3.8 x 3.8"	1.3 lbs. (0.6 kg)	UL File No. E234324
01801.0-00	AC 230 V, 50 Hz ¹⁾	32 cfm (55 m ³ /h)	25 cfm (42 m ³ /h)	15 W	40 dB (A)	2.3" (58 mm)	4.9 x 4.9"	2.2 lbs. (1.0 kg)	UL File No. E234324, VDE
01801.0-01	AC 120 V, 60 Hz	37 cfm (63 m ³ /h)	28 cfm (48 m ³ /h)	15 W	40 dB (A)	2.3" (58 mm)	4.9 x 4.9"	2.2 lbs. (1.0 kg)	UL File No. E234324
01802.0-00	AC 230 V, 50 Hz ¹⁾	60 cfm (102 m ³ /h)	40 cfm (68 m ³ /h)	15 W	39 dB (A)	3.4" (86 mm)	6.9 x 6.9"	2.9 lbs. (1.3 kg)	UL File No. E234324, VDE
01802.0-01	AC 120 V, 60 Hz	69 cfm (117 m ³ /h)	46 cfm (78 m ³ /h)	15 W	39 dB (A)	3.4" (86 mm)	6.9 x 6.9"	2.9 lbs. (1.3 kg)	UL File No. E234324

¹⁾ air volume increases by 15% when operating AC 230 V filter fans at 60 Hz

Specifications are subject to change without notice. Suitability of this product for its intended use and any associated risks must be determined by the end customer/ buyer in its final application.

Time-saving assembly and maintenance

STEGO's filter fans are easily installed by one person **from outside** the cabinet.

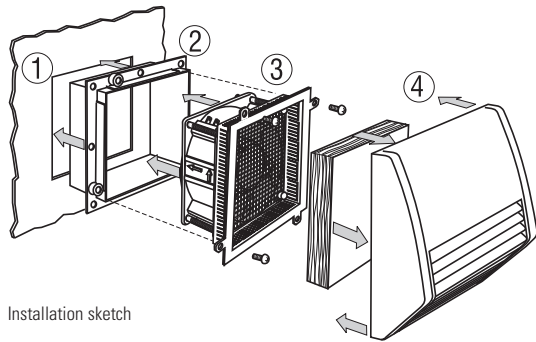

Installation sketch

- 1.) Make cut-out in the cabinet wall. The cut edge of the cabinet opening should be free of dirt, filings and grease. A template for the enclosure cut-out is included with the filter fan.
- 2.) Remove protective film from the sealing strips on the mounting frame. Press mounting frame into the cabinet opening. The frame stays permanently in the cabinet.
- 3.) Electrically connect the axial fan using the cage clamp connectors. Push the unit into the mounting frame. Affix using screws if necessary.
- 4.) Insert the filter mat in the hood. Clip on. Finished.

To change the filter mat, simply remove the filter hood, insert the new mat and snap the hood back again. No tools are required. Maintenance of the fan can easily be performed without removing the mounting frame (2).

Dimensional Drawing

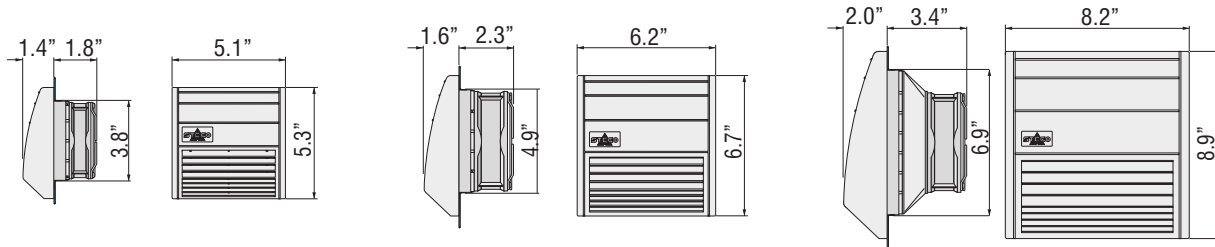

Drilling template for mounting frame

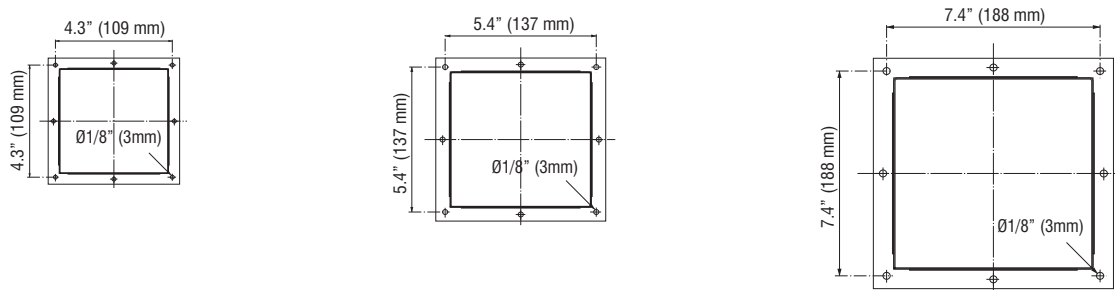

EF 118 Exhaust Filter

Part No.	Mounting depth	Enclosure cut-out	Weight (approx.)	Filter mat	Protection type	Approvals
11800.0-00	0.6" (16 mm)	3.8 x 3.8"	0.6 lbs. (0.3 kg)	G4 acc. to DIN EN 779, filtering degree 94 %	IP55*	UL File No. E234324
11801.0-00	0.6" (16 mm)	4.9 x 4.9"	0.8 lbs. (0.4 kg)	G4 acc. to DIN EN 779, filtering degree 94 %	IP55*	UL File No. E234324
11802.0-00	0.6" (16 mm)	6.9 x 6.9"	1.3 lbs. (0.6 kg)	G4 acc. to DIN EN 779, filtering degree 94 %	IP55*	UL File No. E234324

*according to VDE

FM 086 Filter Mats

Filter mat	3.5 x 3.5" (89 x 89 mm)	4.6 x 4.6" (118 x 118 mm)	6.6 x 6.6" (168 x 168 mm)
G4 (1 packing unit = 3 pcs.)	Part No. 08600.0-00	Part No. 08601.0-00	Part No. 08602.0-00
F5 (1 packing unit = 3 pcs.)	Part No. 08603.0-00	Part No. 08604.0-00	Part No. 08605.0-00

Specifications are subject to change without notice. Suitability of this product for its intended use and any associated risks must be determined by the end customer/ buyer in its final application.