

**REMA Ringschraube G-8140**

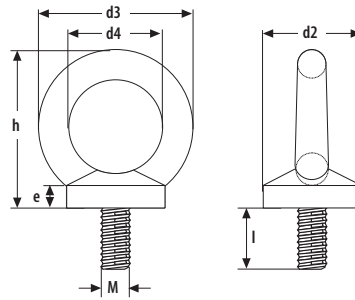

Material : Karbon Stahl, C15, DIN 580, Sicherheitsfaktor : Mindestbruchlast = 6-fache WLL.  
Oberflächenbehandlung : Galvanisch verzinkt.

**Norm:**  
- DIN582



Typ	Tragfähigkeit (kg)	D2 (mm)	D3 (mm)	D4 (mm)	E (mm)	H (mm)	L (mm)	M (mm)	Gewicht (kg/st/m)	Artikel-Nr.
G8140-M8	140	20	36	20	6	36	13	8	0.06	3015001
G8140-M10	230	25	45	25	8	45	17	10	0.11	3015003
G8140-M12	340	30	54	30	10	53	20.5	12	0.18	3015005
G8140-M14	490	35	63	35	12	60	27	14	0.28	3015007
G8140-M16	700	35	63	35	12	62	27	16	0.28	3015009
G8140-M20	1200	40	72	40	14	71	30	20	0.43	3015011
G8140-M24	1800	50	90	50	18	90	36	24	0.84	3015013
G8140-M27	2500	50	90	50	18	90	36	27	1.22	3015015
G8140-M30	3200	65	108	60	22	109	45	30	1.66	3015017
G8140-M36	4600	75	196	70	26	128	54	36	2.65	3015019

**REMA Ringmutter G-8142**



Material : Karbon Stahl, C15, DIN 580, Sicherheitsfaktor : Mindestbruchlast = 6-fache WLL.  
Oberflächenbehandlung : Galvanisch verzinkt.

**Norm:**  
- DIN582

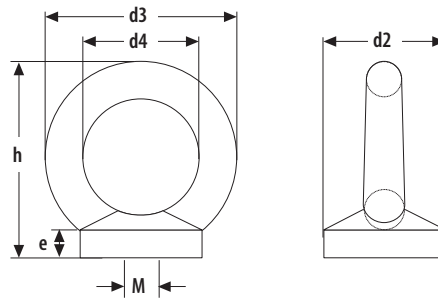

Typ	Tragfähigkeit (kg)	D2 (mm)	D3 (mm)	D4 (mm)	E (mm)	H (mm)	M (mm)	Gewicht (kg/pce/m)	Artikel-Nr.
G8142-M8	140	20	36	20	8.5	36	8	0.6	3017001
G8142-M10	230	25	45	25	10	45	10	0.1	3017003
G8142-M12	340	30	54	30	11	53	12	0.16	3017005
G8142-M14	490	35	63	35	13	62	14	0.24	3017007
G8142-M16	700	35	63	35	13	62	16	0.24	3017009
G8142-M20	1200	40	72	40	16	71	20	0.36	3017011
G8142-M24	1800	50	90	50	20	90	24	0.71	3017013
G8142-M27	2500	50	90	50	20	90	27	1.1	3017015
G8142-M30	3200	65	108	60	25	109	30	1.32	3017017
G8142-M36	4600	75	126	70	30	128	36	2.08	3017019