



CE

Model Number**OMH-ML300-01**

Bracket for mounting ML300 series sensors

Features

- Mounting accessories for ML300 series sensors
- Simple and fast mounting

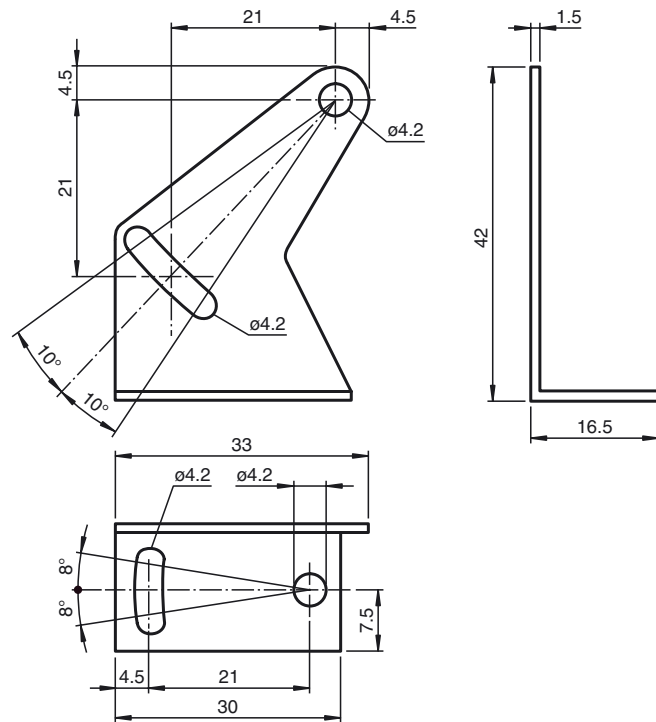
Dimensions**Technical data****Mechanical specifications**

Material	Zink plated steel
Mass	approx. 13 g
Mounting	Mounting accessories included

Suitable series

Series	ML300
--------	-------