



DC COMPONENTS CO., LTD.

DISCRETE SEMICONDUCTORS

2N3904

TECHNICAL SPECIFICATIONS OF NPN EPITAXIAL PLANAR TRANSISTOR

Description

Designed for general purpose switching and amplifier applications.

Pinning

- 1 = Emitter
- 2 = Base
- 3 = Collector

Absolute Maximum Ratings(T<sub>A</sub>=25°C)

Characteristic	Symbol	Rating	Unit
Collector-Base Voltage	V <sub>CB0</sub>	60	V
Collector-Emitter Voltage	V <sub>CE0</sub>	40	V
Emitter-Base Voltage	V <sub>EB0</sub>	6	V
Collector Current	I <sub>C</sub>	200	mA
Total Power Dissipation	P <sub>D</sub>	625	mW
Junction Temperature	T <sub>J</sub>	+150	°C
Storage Temperature	T <sub>STG</sub>	-55 to +150	°C

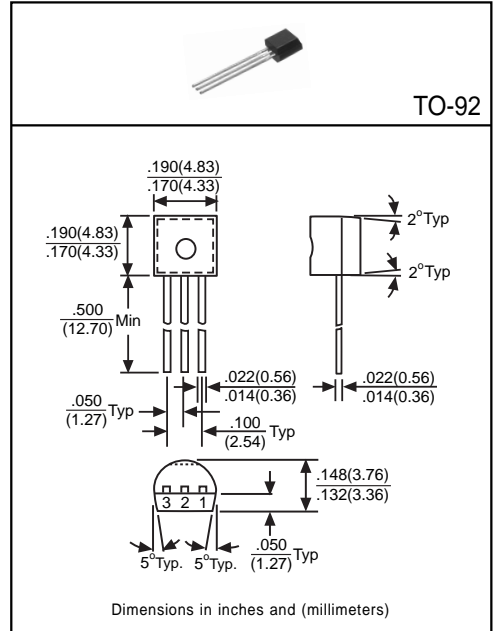

Electrical Characteristics

(Ratings at 25°C ambient temperature unless otherwise specified)

Characteristic	Symbol	Min	Typ	Max	Unit	Test Conditions
Collector-Base Breakdown Voltage	BV <sub>CB0</sub>	60	-	-	V	I <sub>C</sub> =10μA, I <sub>E</sub> =0
Collector-Emitter Breakdown Voltage	BV <sub>CE0</sub>	40	-	-	V	I <sub>C</sub> =1mA, I <sub>B</sub> =0
Emitter-Base Breakdown Voltage	BV <sub>EB0</sub>	6	-	-	V	I <sub>E</sub> =10μA, I <sub>C</sub> =0
Collector Cutoff Current	I <sub>CEX</sub>	-	-	50	nA	V <sub>CE</sub> =30V, V <sub>BE</sub> =3V
Collector-Emitter Saturation Voltage <sup>(1)</sup>	V <sub>CE(sat)1</sub>	-	-	0.2	V	I <sub>C</sub> =10mA, I <sub>B</sub> =1mA
	V <sub>CE(sat)2</sub>	-	-	0.3	V	I <sub>C</sub> =50mA, I <sub>B</sub> =5mA
Base-Emitter Saturation Voltage <sup>(1)</sup>	V <sub>BE(sat)1</sub>	0.65	-	0.85	V	I <sub>C</sub> =10mA, I <sub>B</sub> =1mA
	V <sub>BE(sat)2</sub>	-	-	0.95	V	I <sub>C</sub> =50mA, I <sub>B</sub> =5mA
DC Current Gain <sup>(1)</sup>	h <sub>FE1</sub>	40	-	-	-	I <sub>C</sub> =0.1mA, V <sub>CE</sub> =1V
	h <sub>FE2</sub>	70	-	-	-	I <sub>C</sub> =1mA, V <sub>CE</sub> =1V
	h <sub>FE3</sub>	100	-	300	-	I <sub>C</sub> =10mA, V <sub>CE</sub> =1V
	h <sub>FE4</sub>	60	-	-	-	I <sub>C</sub> =50mA, V <sub>CE</sub> =1V
	h <sub>FE5</sub>	30	-	-	-	I <sub>C</sub> =100mA, V <sub>CE</sub> =1V
Transition Frequency	f <sub>T</sub>	300	-	-	MHz	I <sub>C</sub> =10mA, V <sub>CE</sub> =20V, f=100MHz
Output Capacitance	C <sub>ob</sub>	-	-	4	pF	V <sub>CB</sub> =5V, f=1MHz, I <sub>E</sub> =0

(1) Pulse Test: Pulse Width ≤ 380μs, Duty Cycle ≤ 2%

## Electrical Characteristic Curves

Total Power Dissipation Curve

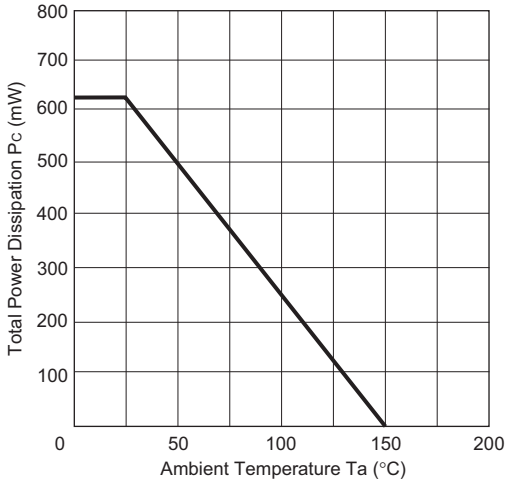

Typical Output Characteristics

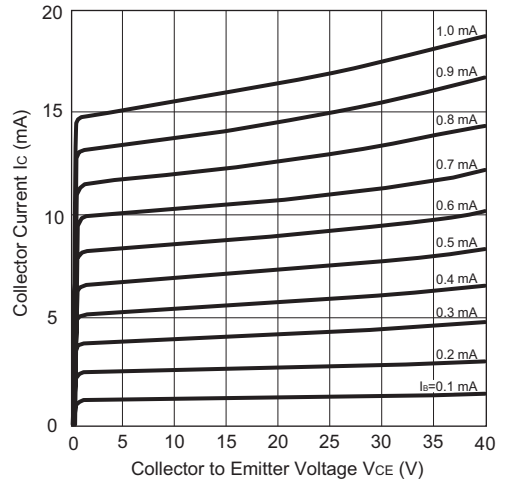

DC Current Transfer Ratio vs. Collector Current

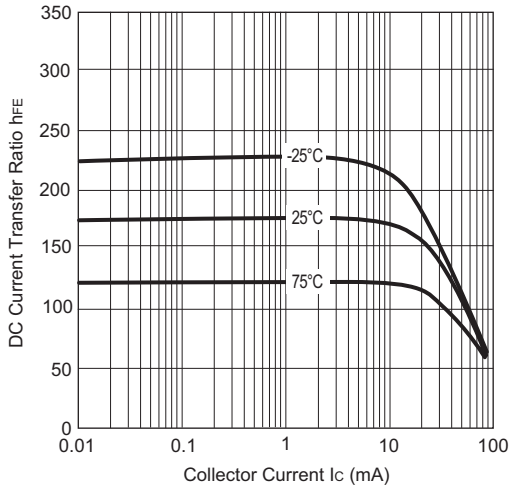

Typical Transfer Characteristics

