

## high-feed milling cutter M370™

for indexable milling inserts WOEJ 0804.., WOEJ 1207..

**WIDIA** 

### Application:

the M370 is designed for high feed rates and high productivity, combining the latest indexable inserts technology with outstanding performance and reliability. the version with double-sided indexable inserts with 6 cutting edges each provides safety, an optimum cutting volume and lower costs per cutting edge.

### Execution:

- extremely high cutting volume
- six cutting edges per indexable insert through double-sided design
- milling cutter body with high stability
- ideal for rough machining with high feed rates
- with internal cooling

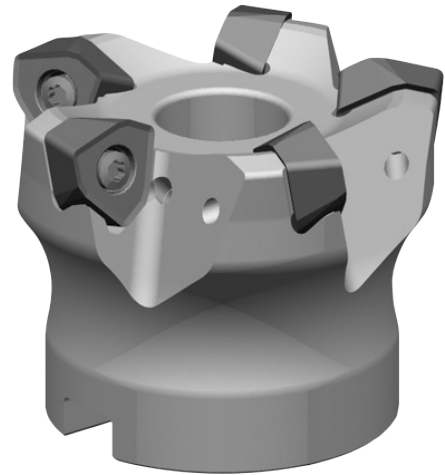

<b>Art. no.</b>	<b>16042 106</b>
<b>Brand</b>	WIDIA
<b>Manufacturer Part Number</b>	53389 16
<b>Max. cutting edge diameter</b>	63 mm
<b>Min. cutting edge diameter</b>	46.09 mm
<b>Length</b>	50 mm
<b>Bore diameter</b>	22 mm
<b>max. ap</b>	2 mm
<b>Number of cutting edges</b>	5 PCS
<b>Gross Weight</b>	0.570 kg
<b>Product Group</b>	1XJ

### EAN

4050839378586