

- 1
- 2
- 3
- 4
- 5
- 6
- 7
- 8
- 9
- 10
- 11
- 12
- 13
- 14
- 15
- 16
- 17
- 18

STANDARD EXECUTIONS

Sintered AISI 316 LHC stainless steel.
 Clamping assembly by means of AISI 304 stainless steel screw, cylindrical head with hexagonal socket.
 Threaded pass-through hole d3 when d1 = 30 ÷ 36.
 Threaded blind hole d3 when d1 ≥ 42.
 - **GN 7062.1-A**: with radial threaded holes.
 - **GN 7062.1-B**: with axial threaded holes.

FEATURES AND APPLICATIONS

GN 7062.1 split set collars are fixed to the shaft by tightening the screw properly. The threaded holes allow to fix brackets for sensor holders GN 7062.10 (see page -) on shafts.
 They can be used not only as end stops, but also for fixing other components, such as end limit switches.
 The clamping screw d3 may be replaced by clamping kit GN 311 (see page -).

TECHNICAL DATA

Assembly on h11 tolerance shafts.

ACCESSORIES

- Dampening washers GN 7062.30 (see page -).
- Sensor holders GN 7062.10 (see page -).



GN 7062.1-A

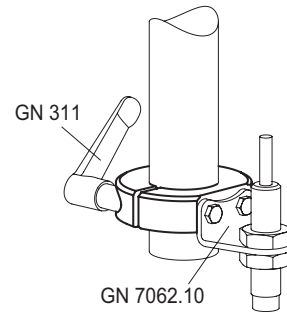
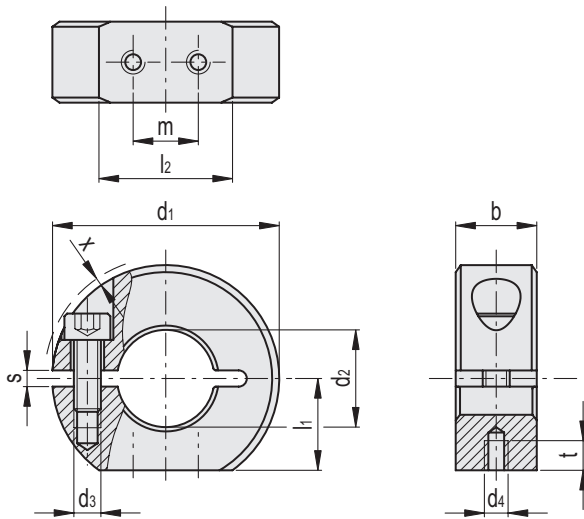

GN 7062.1-A

Code	Description	d1	d2 H10	d3	d4	b±0.2	l1	l2	m	s	t	x*	d3 Clamping kit	⚖
GN.73501	GN 7062.1-30-B12-NI-A	30	12	M4	M3	11	13	15	8	2.1	4	0.7	GN 311-30-M4-12-SW	38
GN.73506	GN 7062.1-32-B14-NI-A	32	14	M4	M3	11	14	15.5	8	2.1	4	0.7	GN 311-30-M4-12-SW	42
GN.73511	GN 7062.1-36-B15-NI-A	36	15	M5	M4	13	15	19.9	10	2.1	5.5	1.4	GN 311-30-M5-13-SW	67
GN.73516	GN 7062.1-36-B16-NI-A	36	16	M5	M4	13	15	19.9	10	2.1	5.5	1.4	GN 311-30-M5-13-SW	61
GN.73521	GN 7062.1-42-B18-NI-A	42	18	M5	M4	15	17	24.7	12	3	5.5	0.6	GN 311-30-M5-15-SW	91
GN.73526	GN 7062.1-42-B20-NI-A	42	20	M5	M4	15	17	24.7	12	3	5.5	0.6	GN 311-30-M5-15-SW	91
GN.73531	GN 7062.1-48-B22-NI-A	48	22	M5	M4	15	20	26.5	12	3	5.5	-	GN 311-45-M5-16-SW	121
GN.73536	GN 7062.1-48-B25-NI-A	48	25	M5	M4	15	20	26.5	12	3	5.5	-	GN 311-45-M5-16-SW	111
GN.73541	GN 7062.1-55-B28-NI-A	55	28	M6	M5	15	22.5	31.6	18	3	7	0.5	GN 311-45-M6-18-SW	145
GN.73546	GN 7062.1-55-B30-NI-A	55	30	M6	M5	15	22.5	31.6	18	3	7	0.5	GN 311-45-M6-18-SW	140
GN.73551	GN 7062.1-60-B32-NI-A	60	32	M6	M5	15	25	33.2	18	4	7	0.4	GN 311-45-M6-19-SW	184
GN.73556	GN 7062.1-60-B35-NI-A	60	35	M6	M5	15	25	33.2	18	4	7	0.4	GN 311-45-M6-19-SW	156
GN.73561	GN 7062.1-65-B40-NI-A	65	40	M6	M5	15	27.5	34.6	18	4	7	0.5	GN 311-45-M6-20-SW	175

Standard machine parts

* Max protrusion of the screw head.



GN 7062.1-B

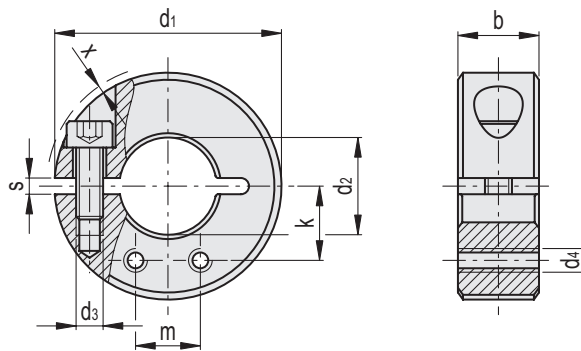

GN 7062.1-B

INOX STAINLESS STEEL

Code	Description	d1	d2 H10	d3	d4	b±0.2	m	k	s	x*	d3 Clamping kit	⚖
GN.73502	GN 7062.1-30-B12-NI-B	30	12	M4	M3	11	8	9.7	2.1	0.7	GN 311-30-M4-12-SW	38
GN.73507	GN 7062.1-32-B14-NI-B	32	14	M4	M3	11	8	10.8	2.1	0.7	GN 311-30-M4-12-SW	42
GN.73512	GN 7062.1-36-B15-NI-B	36	15	M5	M4	13	10	11.7	2.1	1.4	GN 311-30-M5-13-SW	71
GN.73517	GN 7062.1-36-B16-NI-B	36	16	M5	M4	13	10	12	2.1	1.4	GN 311-30-M5-13-SW	63
GN.73522	GN 7062.1-42-B18-NI-B	42	18	M5	M4	15	12	13.7	3	0.6	GN 311-30-M5-15-SW	99
GN.73527	GN 7062.1-42-B20-NI-B	42	20	M5	M4	15	12	14.3	3	0.6	GN 311-30-M5-15-SW	94
GN.73532	GN 7062.1-48-B22-NI-B	48	22	M5	M4	15	12	16.4	3	-	GN 311-45-M5-16-SW	128
GN.73537	GN 7062.1-48-B25-NI-B	48	25	M5	M4	15	12	17.2	3	-	GN 311-45-M5-16-SW	116
GN.73542	GN 7062.1-55-B28-NI-B	55	28	M6	M5	15	18	18.7	3	0.5	GN 311-45-M6-18-SW	158
GN.73547	GN 7062.1-55-B30-NI-B	55	30	M6	M5	15	18	19.3	3	0.5	GN 311-45-M6-18-SW	148
GN.73552	GN 7062.1-60-B32-NI-B	60	32	M6	M5	15	18	21.2	4	0.4	GN 311-45-M6-19-SW	193
GN.73557	GN 7062.1-60-B35-NI-B	60	35	M6	M5	15	18	22	4	0.4	GN 311-45-M6-19-SW	164
GN.73562	GN 7062.1-65-B40-NI-B	65	40	M6	M5	15	18	24.7	4	0.5	GN 311-45-M6-20-SW	184

* Max protrusion of the screw head.