

GN 7072.3 | Dismountable split set collars

with dampening washer, stainless steel



- 1
- 2
- 3
- 4
- 5
- 6
- 7
- 8
- 9
- 10
- 11
- 12
- 13
- 14
- 15
- 16
- 17
- 18

STANDARD EXECUTION

Sintered AISI 316 LHC stainless steel.
Clamping assembly by means of two AISI 304 stainless steel screws, cylindrical head with hexagon socket.
Threaded pass-through hole d3 when d1 = 30 ÷ 36.
Threaded blind hole d3 when d1 ≥ 42.

DAMPENING WASHER

Transparent polyurethane (PUR), hardness 70 Shore A. Resistant up to 80°C.

FEATURES AND APPLICATIONS

GN 7072.3 dismountable split set collars are assembled and fixed to the shaft by tightening the screw properly. They can be used not only as end stops, but also for fixing other components, such as end limit switches.

The dampening washer GN 7072.30 (see page -), supplied already fixed by means of an adhesive film on the semi-split set collar, absorbs light impacts and has a dampening effect when they come into contact with other components.

Compared to the single-body set collars, the dismountable split set collars can be positioned on the shaft without having to insert them from the end.

The clamping screw d3 may be replaced by clamping kit GN 311 (see page -).

TECHNICAL DATA

Assembly on h11 tolerance shafts.

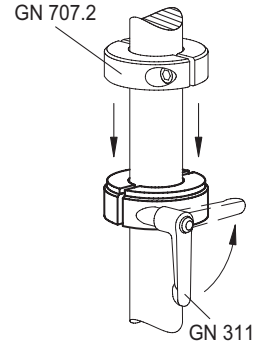
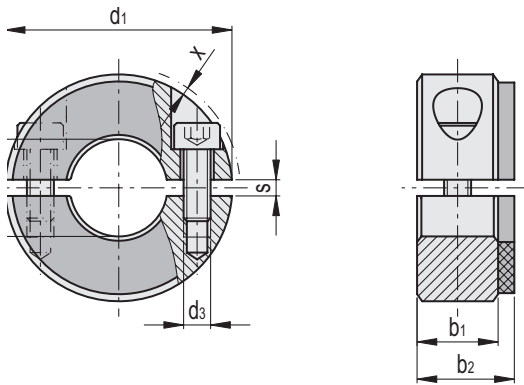

Code	Description	d1	d2 H10	d3	b1	b2	s	x*	d3 Clamping kit	⚖
GN.75401	GN 7072.3-30-B12-NI	30	12	M4	11	13	2.1	0.7	GN 311-30-M4-12-SW	38
GN.75406	GN 7072.3-32-B14-NI	32	14	M4	11	13	2.1	0.7	GN 311-30-M4-12-SW	46
GN.75411	GN 7072.3-36-B15-NI	36	15	M5	13	15	2.1	1.4	GN 311-30-M5-13-SW	113
GN.75412	GN 7072.3-36-B16-NI	36	16	M5	13	15	2.1	1.4	GN 311-30-M5-13-SW	111
GN.75416	GN 7072.3-42-B18-NI	42	18	M5	15	18	3	0.6	GN 311-30-M5-15-SW	103
GN.75417	GN 7072.3-42-B20-NI	42	20	M5	15	18	3	0.6	GN 311-30-M5-15-SW	100
GN.75421	GN 7072.3-48-B22-NI	48	22	M5	15	18	3	-	GN 311-45-M5-16-SW	115
GN.75422	GN 7072.3-48-B25-NI	48	25	M5	15	18	3	-	GN 311-45-M5-16-SW	110
GN.75426	GN 7072.3-55-B28-NI	55	28	M6	15	18	3	0.5	GN 311-45-M6-18-SW	167
GN.75427	GN 7072.3-55-B30-NI	55	30	M6	15	18	3	0.5	GN 311-45-M6-18-SW	160
GN.75431	GN 7072.3-60-B32-NI	60	32	M6	15	18	4	0.4	GN 311-45-M6-19-SW	167
GN.75432	GN 7072.3-60-B35-NI	60	35	M6	15	18	4	0.4	GN 311-45-M6-19-SW	165
GN.75436	GN 7072.3-65-B40-NI	65	40	M6	15	18	4	0.5	GN 311-45-M6-20-SW	185

Standard machine parts

* Max protrusion of the screw head.