



Product Change Notification / SYST-25TIQE746

Date:

26-May-2021

Product Category:

CPU / System Supervisors, Power Management - System Supervisors/Voltage Detectors

PCN Type:

Document Change

Notification Subject:

Data Sheet - TC1270A/TC1270AN/TC1271A Voltage Supervisor with Manual Reset Input Data Sheet Document Revision

Affected CPNs:

[SYST-25TIQE746_Affected_CPN_05262021.pdf](#)

[SYST-25TIQE746_Affected_CPN_05262021.csv](#)

Notification Text:

SYST-25TIQE746

Microchip has released a new Product Documents for the TC1270A/TC1270AN/TC1271A Voltage Supervisor with Manual Reset Input Data Sheet of devices. If you are using one of these devices please read the document located at [TC1270A/TC1270AN/TC1271A Voltage Supervisor with Manual Reset Input Data Sheet](#).

Notification Status: Final

Description of Change:

The following is the list of modifications:

- 1) Updated the Features section.
- 2) Updated the Temperature Characteristics table.
- 3) Updated Section 9.0 "Packaging information" with Automotive examples and current Package Drawings.
- 4) Updated the Product Identification System to include Automotive examples.
- 5) Minor editorial corrections.

Impacts to Data Sheet: None

Reason for Change: To Improve Manufacturability

Change Implementation Status: Complete

Date Document Changes Effective: 26 May 2021

NOTE: Please be advised that this is a change to the document only the product has not been changed.

Markings to Distinguish Revised from Unrevised Devices: N/A

Attachments:

[TC1270A/ TC1270AN/ TC1271A Voltage Supervisor with Manual Reset Input Data Sheet](#)

Please contact your local [Microchip sales office](#) with questions or concerns regarding this notification.

Terms and Conditions:

If you wish to receive Microchip PCNs via email please register for our PCN email service at our [PCN home page](#) select register then fill in the required fields. You will find instructions about registering for Microchips PCN email service in the [PCN FAQ](#) section.

If you wish to change your PCN profile, including opt out, please go to the [PCN home page](#) select login and sign into your myMicrochip account. Select a profile option from the left navigation bar and make the applicable selections.

Affected Catalog Part Numbers (CPN)

TC1270ARVCTTR
TC1270ASVCTTR
TC1270ATVCTTR
TC1270AMVCTTR
TC1270ALVCTTR
TC1270ANRVCTTR
TC1270ANSVCTTR
TC1270ANTVCTTR
TC1270ANMVCTTR
TC1270ANLVCTTR
TC1270ARVRCTR
TC1270ASVRCTR
TC1270ATVRCTR
TC1270AMVRCTR
TC1270ALVRCTR
TC1270ARVRCTRAAA
TC1270ANRVRCTR
TC1270ANSVRCTR
TC1270ANTVRCTR
TC1270ANMVRCTR
TC1270ANLVRCTR
TC1270ARVRCTR-VAO
TC1270ARVRCTR
TC1270ASVRCTR
TC1270ATVRCTR
TC1270AMVRCTR
TC1270ALVRCTR
TC1270ARVRCTRAAA
TC1270ANRVRCTR
TC1270ANSVRCTR
TC1270ANTVRCTR
TC1270ANMVRCTR
TC1270ANLVRCTR
TC1270ARAVCTTR
TC1270ASAVCTTR
TC1270ATAVCTTR
TC1270AMAVCTTR
TC1270ALAVCTTR
TC1270ANRAVCTTR
TC1270ANSAVCTTR
TC1270ANTAVCTTR
TC1270ANMAVCTTR
TC1270ANLAVCTTR
TC1270ATAVCTTR-V01
TC1270ANMAVCTTR-V02
TC1270ARAVRCTR

TC1270ASAVRCTR
TC1270ATAVRCTR
TC1270AMAVRCTR
TC1270ALAVRCTR
TC1270ANRAVRCTR
TC1270ANSAVRCTR
TC1270ANTAVRCTR
TC1270ANMAVRCTR
TC1270ANLAVRCTR
TC1270ARAVRCTR
TC1270ASAVRCTR
TC1270ATAVRCTR
TC1270AMAVRCTR
TC1270ALAVRCTR
TC1270ANRAVRCTR
TC1270ANSAVRCTR
TC1270ANTAVRCTR
TC1270ANMAVRCTR
TC1270ANLAVRCTR
TC1270ARBVCTTR
TC1270ASBVCTTR
TC1270ATBVCTTR
TC1270AMBVCTTR
TC1270ALBVCTTR
TC1270ANRBVCTTR
TC1270ANSBVCTTR
TC1270ANTBVCTTR
TC1270ANMBVCTTR
TC1270ANLBVCTTR
TC1270ANSBVCTTR-V01
TC1270AMBVCTTR-V02
TC1270ASBVCTTRVAO
TC1270AMBVCTTR-VAO
TC1270ANSBVCTTR-VAO
TC1270ARBVRCTR
TC1270ASBVRCTR
TC1270ATBVRCTR
TC1270AMBVRCTR
TC1270ALBVRCTR
TC1270ANRBVRCTR
TC1270ANSBVRCTR
TC1270ANTBVRCTR
TC1270ANMBVRCTR
TC1270ANLBVRCTR
TC1270ARBVRCTR
TC1270ASBVRCTR
TC1270ATBVRCTR
TC1270AMBVRCTR
TC1270ALBVRCTR

TC1270ANRBVRCTR
TC1270ANSBVRCTR
TC1270ANTBVRCTR
TC1270ANMBVRCTR
TC1270ANLBVRCTR
TC1270ANRVCTTR
TC1270ANSVCTTR
TC1270ANTVCTTR
TC1270ANMVCTTR
TC1270ANLVCTTR
TC1270ANRVRCTR
TC1270ANSVRCTR
TC1270ANTVRCTR
TC1270ANMVRCTR
TC1270ANLVRCTR
TC1270ANRVRCTR
TC1270ANSVRCTR
TC1270ANTVRCTR
TC1270ANMVRCTR
TC1270ANLVRCTR
TC1270ANRAVCTTR
TC1270ANSAVCTTR
TC1270ANTAVCTTR
TC1270ANMAVCTTR
TC1270ANLAVCTTR
TC1270ANMAVCTTR-V02
TC1270ANRAVRCTR
TC1270ANSAVRCTR
TC1270ANTAVRCTR
TC1270ANMAVRCTR
TC1270ANLAVRCTR
TC1270ANRAVRCTR
TC1270ANSAVRCTR
TC1270ANTAVRCTR
TC1270ANMAVRCTR
TC1270ANLAVRCTR
TC1270ANRBVCTTR
TC1270ANSBVCTTR
TC1270ANTBVCTTR
TC1270ANMBVCTTR
TC1270ANLBVCTTR
TC1270ANSBVCTTR-V01
TC1270ANSBVCTTR-VAO
TC1270ANRBVRCTR
TC1270ANSBVRCTR
TC1270ANTBVRCTR
TC1270ANMBVRCTR
TC1270ANLBVRCTR
TC1270ANRBVRCTR

TC1270ANSBVRCTR
TC1270ANTBVRCTR
TC1270ANMBVRCTR
TC1270ANLBVRCTR
TC1271ARVCTTR
TC1271ASVCTTR
TC1271ATVCTTR
TC1271AMVCTTR
TC1271ALVCTTR
TC1271ARVRCTR
TC1271ASVRCTR
TC1271ATVRCTR
TC1271AMVRCTR
TC1271ALVRCTR
TC1271ARVRCTR
TC1271ASVRCTR
TC1271ATVRCTR
TC1271AMVRCTR
TC1271ALVRCTR
TC1271ARAVCTTR
TC1271ASAVCTTR
TC1271ATAVCTTR
TC1271AMAVCTTR
TC1271ALAVCTTR
TC1271ARAVRCTR
TC1271ASAVRCTR
TC1271ATAVRCTR
TC1271AMAVRCTR
TC1271ALAVRCTR
TC1271ARAVRCTR
TC1271ASAVRCTR
TC1271ATAVRCTR
TC1271AMAVRCTR
TC1271ALAVRCTR
TC1271ARBVCTTR
TC1271ASBVCTTR
TC1271ATBVCTTR
TC1271AMBVCTTR
TC1271ALBVCTTR
TC1271ARBVRCTR
TC1271ASBVRCTR
TC1271ATBVRCTR
TC1271AMBVRCTR
TC1271ALBVRCTR
TC1271ARBVRCTR
TC1271ASBVRCTR
TC1271ATBVRCTR
TC1271AMBVRCTR
TC1271ALBVRCTR

Voltage Supervisor with Manual Reset Input

Features

- Precision Voltage Monitor
 - 2.63V, 2.93V, 3.08V, 4.38V and 4.63V Trip Points (Typical)
- Manual Reset Input
- Reset Time-Out Delay:
 - Standard: 280 ms (Typical)
 - Optional: 2.19 ms, and 35 ms (Typical)
- Power Consumption $\leq 15 \mu\text{A}$ max
- No glitches on outputs during power-up
- Active Low Output Options:
 - Push-Pull Output and Open-Drain Output
- Active High Output Option:
 - Push-Pull Output
- Replacement for (Specification compatible with):
 - TC1270, TC1271
 - TCM811, TCM812
- Fully Static Design
- Low-Voltage Operation (1.0V)
- ESD Protection:
 - ≥ 4 kV Human Body Model (HBM)
 - ≥ 400 V Machine Model (MM)
- Extended (E) Temperature Range:
 - -40°C to $+125^\circ\text{C}$
- Package Options:
 - 4-Lead SOT-143
 - 5-Lead SOT-23
 - Pb-free Device
- Pass Automotive AEC-Q100 Reliability Testing

Package Types

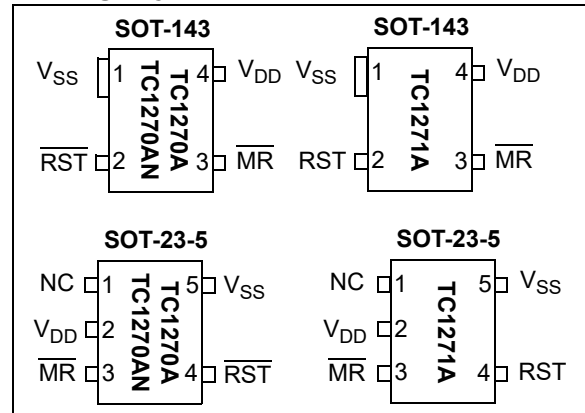

Functional Block Diagram

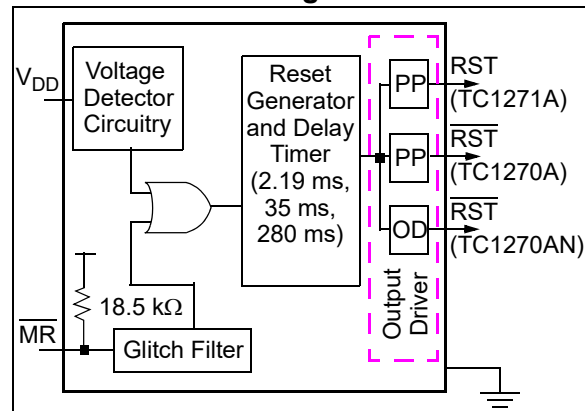

Device Features

Device	Output		Reset Delay (ms) (Typ) ⁽³⁾	Reset Trip Point (V) ⁽³⁾	Voltage Range (V)	Temperature Range	Packages	Comment
	Type	Active Level						
TC1270A	Push-Pull	Low	2.19, 35, 280 ⁽¹⁾	4.63, 4.38, 3.08, 2.93, 2.63 ⁽⁴⁾	1.0V to 5.5V	-40°C to $+125^\circ\text{C}$	SOT-143 ⁽²⁾ , SOT-23-5	Replaces TC1270 and TCM811
TC1270AN	Open-Drain	Low					SOT-143 ⁽²⁾ , SOT-23-5	New Option
TC1271A	Push-Pull	High					SOT-143 ⁽²⁾ , SOT-23-5	Replaces TC1271 and TCM812

- Note**
- The 280 ms Reset delay time-out is compatible with the TC1270, TC1271, TCM811 and TCM812 devices.
 - The SOT-143 package is compatible with the TC1270, TC1271, TCM811 and TCM812 devices.
 - Custom Reset trip points and Reset delays available, contact your local Microchip sales office.
 - The TC1270/1 and TCM811/12 1.75V trip point option is not supported.

TC1270A/70AN/71A

1.0 ELECTRICAL CHARACTERISTICS

Absolute Maximum Ratings †

Supply Voltage (V_{DD} to V_{SS})	+7.0V
Input Current, V_{DD}	10 mA
Output Current, RESET, Reset	10 mA
Voltage on all inputs and outputs w.r.t. V_{SS}	-0.6V to ($V_{DD} + 1.0V$)
Storage Temperature Range	-65°C to +150°C
Operating Temperature Range	-40°C to +125°C
Maximum Junction Temperature, T_J	150°C
ESD protection on all pins	
Human Body Model	≥ 4 kV
Machine Model	≥ 400V

† **Notice:** Stresses above those listed under “Absolute Maximum Ratings” may cause permanent damage to a device. The absolute maximum values are merely stress ratings – functional operation of a device at those, or any other conditions above those indicated in the operational listing of these specifications, is not implied. Exposure to absolute maximum rating conditions for extended periods may affect device reliability.

ELECTRICAL CHARACTERISTICS

Electrical Characteristics: Unless otherwise noted, $V_{DD} = 5V$ for L/M versions, $V_{DD} = 3.3V$ for T/S versions, $V_{DD} = 3V$ for R version, $T_A = -40°C$ to +125°C. Typical values are at $T_A = +25°C$.

Parameter	Sym.	Min.	Typ. ⁽¹⁾	Max.	Units	Test Conditions
Operating Voltage Range	V_{DD}	1.0	—	5.5	V	
Supply Current	I_{DD}	—	7	15	μA	$V_{DD} > V_{TRIP}$, for L/M/R/S/T, $V_{DD} = 5.5V$
		—	4.75	10	μA	$V_{DD} > V_{TRIP}$, for R/S/T, $V_{DD} = 3.6V$
		—	10	15	μA	$V_{DD} < V_{TRIP}$, for L/M/R/S/T
Reset Trip Point Threshold ⁽³⁾	V_{TRIP}	4.54	4.63	4.72	V	TC127xAL: $T_A = +25°C$
		4.50	—	4.75	V	$T_A = -40°C$ to +125°C
		4.30	4.38	4.46	V	TC127xAM: $T_A = +25°C$
		4.25	—	4.50	V	$T_A = -40°C$ to +125°C
		3.03	3.08	3.14	V	TC127xAT: $T_A = +25°C$
		3.00	—	3.15	V	$T_A = -40°C$ to +125°C
		2.88	2.93	2.98	V	TC127xAS: $T_A = +25°C$
		2.85	—	3.00	V	$T_A = -40°C$ to +125°C
		2.72	2.77	2.82	V	TC127xA: ⁽⁵⁾ $T_A = +25°C$
		2.70	—	2.85	V	$T_A = -40°C$ to +125°C
		2.58	2.63	2.68	V	TC127xAR: $T_A = +25°C$
2.55	—	2.70	V	$T_A = -40°C$ to +125°C		

- Note 1:** Data in the Typical (“Typ.”) column is at 5V, +25°C, unless otherwise stated.
- 2:** \overline{RST} output for TC1270A and TC1270AN, RST output for TC1271A.
- 3:** TC127XA refers to the TC1270A, TC1270AN or TC1271A device.
- 4:** Hysteresis is within the $V_{TRIP(MIN)}$ to $V_{TRIP(MAX)}$ window.
- 5:** Custom-ordered voltage trip point. Minimum order volume requirement.
- 6:** This specification allows this device to be used in PIC[®] microcontroller applications that require the In-Circuit Serial Programming™ (ICSP™) feature (see device-specific programming specifications for voltage requirements). The total time that the RST pin can be above the maximum device operational voltage (5.5V) is 100s. Current into the RST pin should be limited to 2 mA. It is recommended that the device operational temperature be maintained between 0°C to +70°C (+25°C preferred). For additional information, refer to [Figure 2-41](#).

TC1270A/70AN/71A

ELECTRICAL CHARACTERISTICS (CONTINUED)

Electrical Characteristics: Unless otherwise noted, $V_{DD} = 5V$ for L/M versions, $V_{DD} = 3.3V$ for T/S versions, $V_{DD} = 3V$ for R version, $T_A = -40^{\circ}C$ to $+125^{\circ}C$. Typical values are at $T_A = +25^{\circ}C$.

Parameter	Sym.	Min.	Typ. ⁽¹⁾	Max.	Units	Test Conditions	
Reset Threshold Tempco		—	±30	—	ppm/°C		
Reset Trip Point Hysteresis ⁽¹⁾	V_{HYS}	—	0.3	—	%	Percentage of V_{TRIP} Voltage	
MR Input High Threshold	V_{IH}	2.3	—	—	V	$V_{DD} > V_{TRIP(MAX)}$, L/M only	
		$0.7 V_{DD}$	—	—	V	$V_{DD} > V_{TRIP(MAX)}$, R/S/T only	
MR Input Low Threshold	V_{IL}	—	—	0.8	V	$V_{DD} > V_{TRIP(MAX)}$, L/M only	
		—	—	$0.25 V_{DD}$	V	$V_{DD} > V_{TRIP(MAX)}$, R/S/T only	
MR Pull-up Resistance		10	18.5	40	kΩ		
Open-Drain High Voltage on Output	V_{ODH}	—	—	13.5	V	Open-Drain Output pin only. $V_{DD} = 3.0V$, Time voltage > 5.5 applied ≤ 100s. Current into pin limited to 2 mA +25°C operation recommended ⁽⁶⁾	
Reset Output Voltage Low ⁽²⁾	TC1270A/TC1270AN	V_{OL}	—	—	0.3	V	R/S/T only, $I_{SINK} = 1.2 mA$, $V_{DD} = V_{TRIP(MIN)}$
	TC1271A		—	—	0.3	V	R/S/T only, $I_{SINK} = 1.2 mA$, $V_{DD} = V_{TRIP(MAX)}$
	TC1270A/TC1270AN		—	—	0.4	V	L/M only, $I_{SINK} = 3.2 mA$, $V_{DD} = V_{TRIP(MIN)}$
	TC1271A		—	—	0.3	V	L/M only, $I_{SINK} = 3.2 mA$, $V_{DD} = V_{TRIP(MAX)}$
	TC1270A/TC1270AN		—	—	0.3	V	L/M only, $I_{SINK} = 50 \mu A$, $V_{DD} > 1.0V$
Reset Output Voltage High ⁽²⁾	TC1270A	V_{OH}	$0.8 V_{DD}$	—	—	V	R/S/T only, $I_{SOURCE} = 500 \mu A$, $V_{DD} = V_{TRIP(MAX)}$
	TC1270A		$V_{DD} - 1.5$	—	—	V	L/M only, $I_{SOURCE} = 800 \mu A$, $V_{DD} = V_{TRIP(MAX)}$
	TC1271A		$0.8 V_{DD}$	—	—	V	$I_{SOURCE} = 500 \mu A$, $V_{DD} \leq V_{TRIP(MIN)}$
Input Leakage Current	I_{IL}	—	—	±1	μA	$V_{PIN} = V_{DD}$	
Open-Drain RST Output Leakage	I_{OLOD}	—	—	1	μA	Open-Drain configuration only.	
Capacitive Loading Specification on Output Pins	C_{IO}	—	—	50	pF		

Note 1: Data in the Typical ("Typ.") column is at 5V, +25°C, unless otherwise stated.

2: RST output for TC1270A and TC1270AN, RST output for TC1271A.

3: TC127XA refers to the TC1270A, TC1270AN or TC1271A device.

4: Hysteresis is within the $V_{TRIP(MIN)}$ to $V_{TRIP(MAX)}$ window.

5: Custom-ordered voltage trip point. Minimum order volume requirement.

6: This specification allows this device to be used in PIC[®] microcontroller applications that require the In-Circuit Serial Programming™ (ICSP™) feature (see device-specific programming specifications for voltage requirements). The total time that the RST pin can be above the maximum device operational voltage (5.5V) is 100s. Current into the RST pin should be limited to 2 mA. It is recommended that the device operational temperature be maintained between 0°C to +70°C (+25°C preferred). For additional information, refer to [Figure 2-41](#).

TC1270A/70AN/71A

1.1 AC CHARACTERISTICS

1.1.1 TIMING PARAMETER SYMBOLOGY

The timing parameter symbols have been created following one of the next formats:

1. TppS2ppS

2. TppS

T			
F	Frequency	T	Time
E	Error		

Lowercase letters (pp) and their meanings:

pp			
io	Input or Output pin	osc	Oscillator
rx	Receive	tx	Transmit
bitclk	RX/TX BITCLK	RST	Reset
drt	Device Reset Timer		

Uppercase letters and their meanings:

S			
F	Fall	P	Period
H	High	R	Rise
I	Invalid (High-impedance)	V	Valid
L	Low	Z	High-impedance

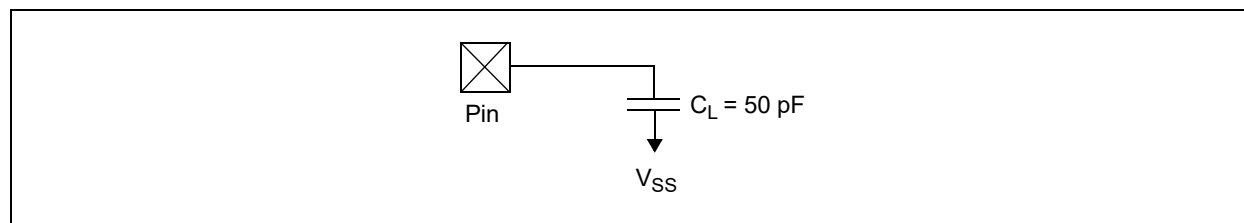
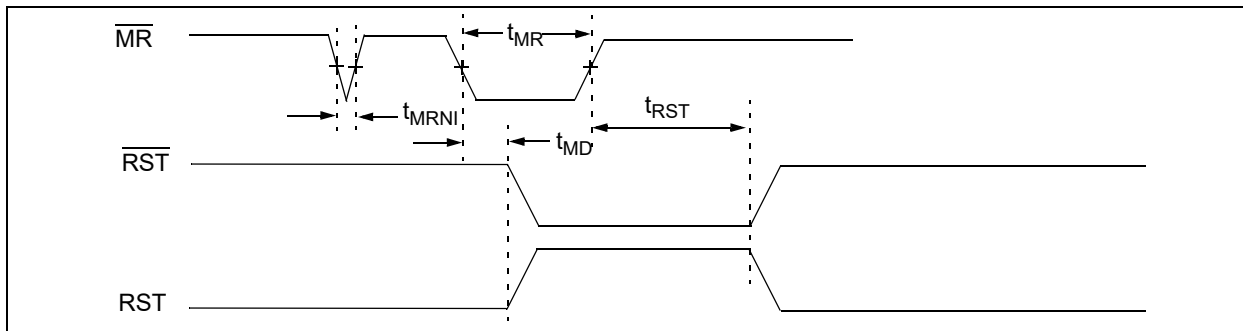

FIGURE 1-1: Test Load Conditions.

TIMING DIAGRAMS AND SPECIFICATIONS

MR Pin and Reset Pin Waveform



Device Voltage and Reset Pin (Active Low) Waveform

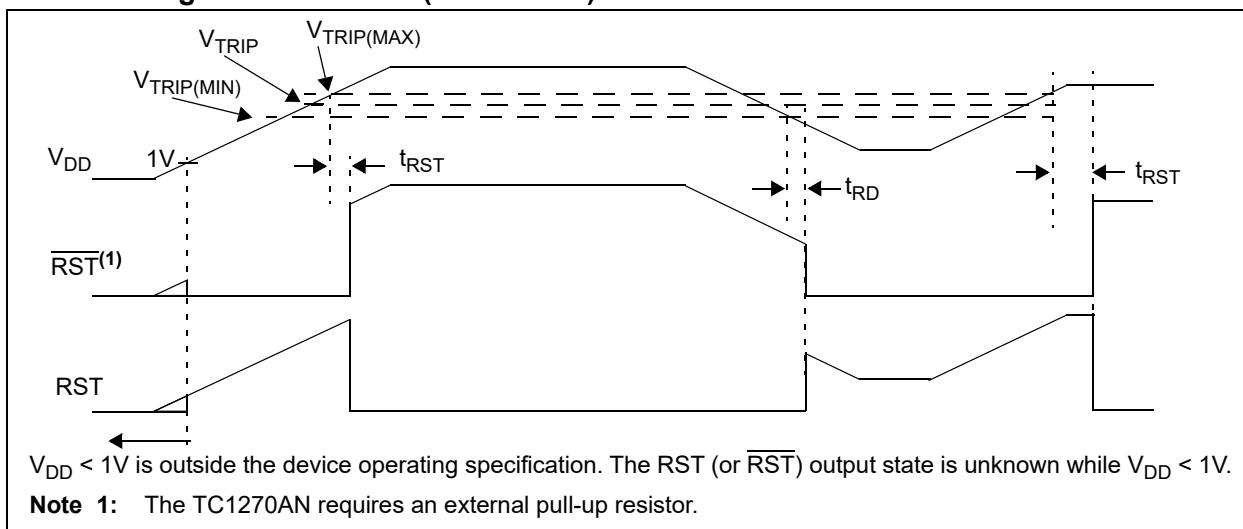

Reset and Device Reset Timer Requirements

Electrical Characteristics: Unless otherwise noted, $V_{DD} = 5V$ for L/M versions, $V_{DD} = 3.3V$ for T/S versions, $V_{DD} = 3V$ for R version, $T_A = -40^\circ C$ to $+125^\circ C$. Typical values are at $T_A = +25^\circ C$.

Parameter		Sym	Min	Typ ⁽¹⁾	Max	Units	Test Conditions
V _{DD} to Reset Delay		t _{RD}	—	50	—	μs	V _{DD} = V _{TRIP(MAX)} to V _{TRIP(MIN)} - 125 mV
Reset Active Time Out Period	TC127XAxBVyy ⁽³⁾	t _{RST}	1.09	2.19	4.38	ms	V _{DD} = V _{TRIP(MAX)}
	TC127XAxAVyy ⁽³⁾		17.5	35	70	ms	V _{DD} = V _{TRIP(MAX)}
	TC127XAxVyy ⁽³⁾		140	280	560	ms	V _{DD} = V _{TRIP(MAX)}
MR Minimum Pulse Width		t _{MR}	10	—	—	μs	
MR Noise Immunity		t _{MRNI}	—	0.1	—	μs	
MR to Reset Propagation Delay		t _{MD}	—	0.2	—	μs	

Note 1: Unless otherwise stated, data in the Typical ("Typ") column is at 5V, +25°C.

2: \overline{RST} output for TC1270A, RST output for TC1271A.

3: TC127XA refers to the TC1270A, TC1270AN or TC1271A device.

"x" indicates the selected voltage trip point, while "yy" indicates the package code.

TC1270A/70AN/71A

TEMPERATURE CHARACTERISTICS

Electrical Specifications: Unless otherwise indicated, $V_{DD} = +1.0V$ to $+5.5V$, $V_{SS} = GND$.						
Parameters	Sym	Min	Typ	Max	Units	Conditions
Temperature Ranges						
Maximum Junction Temperature Range	T_J	-40	—	+150	°C	
Operating Temperature Range	T_A	-40	—	+125	°C	
Storage Temperature Range	T_S	-65	—	+150	°C	
Thermal Package Resistances						
Thermal Resistance, 5L-SOT-23	θ_{JA}	—	256	—	°C/W	
Thermal Resistance, 4L-SOT-143	θ_{JA}	—	426	—	°C/W	

TC1270A/70AN/71A

2.0 TYPICAL PERFORMANCE CURVES

Note: The graphs and tables that follow this note are the result of a statistical summary based on a limited number of samples and are provided for informational purposes only. The performance characteristics listed herein are not tested or guaranteed. In some graphs or tables, the data presented may be outside the specified operating range (e.g., outside specified power supply range) and therefore outside the warranted range.

Note: Unless otherwise indicated, all limits are specified for $V_{DD} = 1V$ to $5.5V$, $T_A = -40^{\circ}C$ to $+125^{\circ}C$.

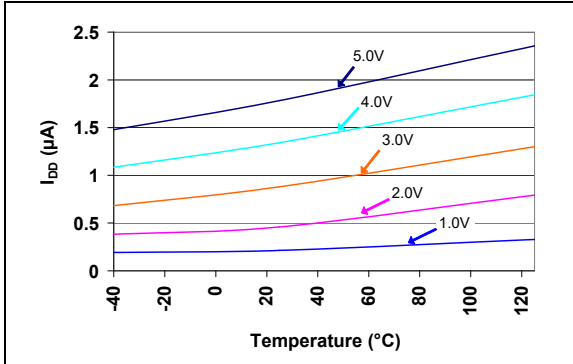

FIGURE 2-1: I_{DD} vs. Temperature (Reset Power-up Timer Inactive)
(TC1270AL, TC1270ANL, TC1271AL
- 4.50V min./4.63V typ./4.75V max.).

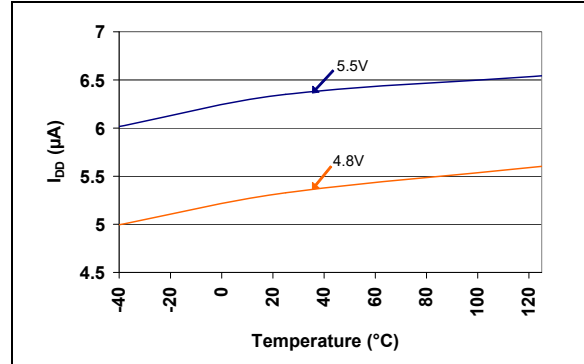

FIGURE 2-4: I_{DD} vs. Temperature (Reset Power-up Timer Active)
(TC1270AL, TC1270ANL, TC1271AL
- 4.50V min./4.63V typ./4.75V max.).

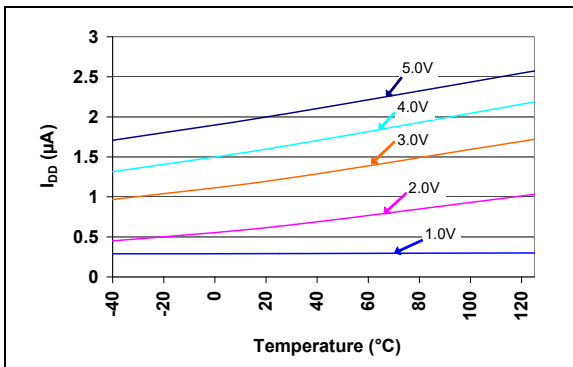

FIGURE 2-2: I_{DD} vs. Temperature (Reset Power-up Timer Inactive)
(TC1270AT, TC1270ANT, TC1271AT
- 3.00V min./3.08V typ./3.15V max.).

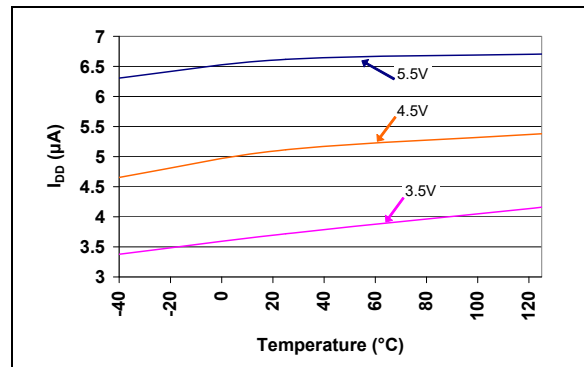

FIGURE 2-5: I_{DD} vs. Temperature (Reset Power-up Timer Active)
(TC1270AT, TC1270ANT, TC1271AT
- 3.00V min./3.08V typ./3.15V max.).

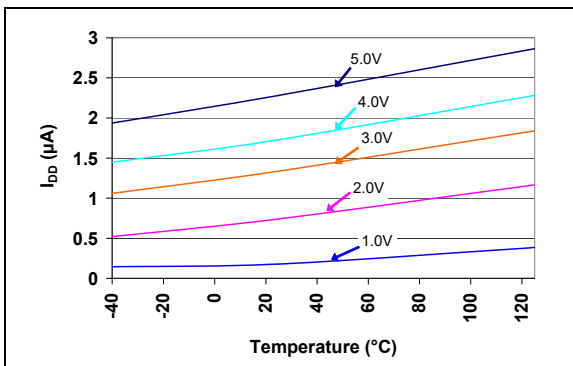

FIGURE 2-3: I_{DD} vs. Temperature (Reset Power-up Timer Inactive)
(TC1270AR, TC1270ANR, TC1271AR
- 2.55V min./2.63V typ./2.70V max.).

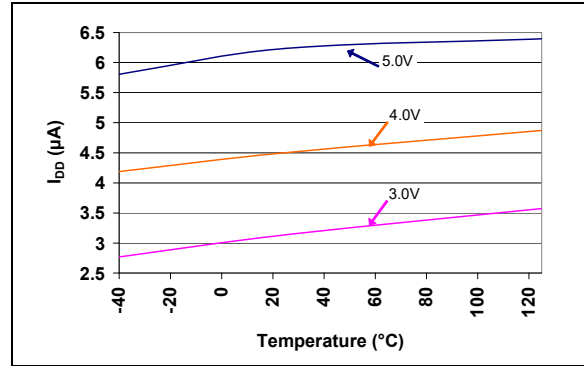

FIGURE 2-6: I_{DD} vs. Temperature (Reset Power-up Timer Active)
(TC1270AR, TC1270ANR, TC1271AR
- 2.55V min./2.63V typ./2.70V max.).

TC1270A/70AN/71A

Note: Unless otherwise indicated, all limits are specified for $V_{DD} = 1V$ to $5.5V$, $T_A = -40^\circ C$ to $+125^\circ C$.

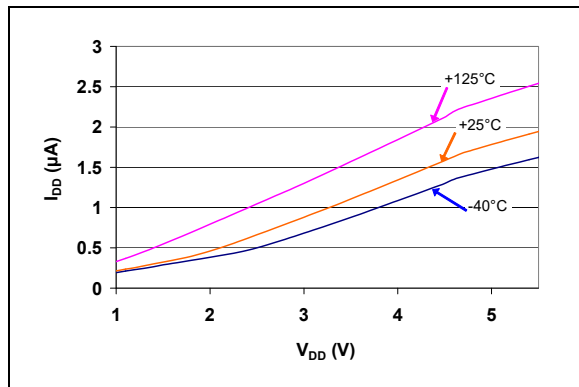

FIGURE 2-7: I_{DD} vs. V_{DD} (Reset Power-up Timer Inactive)
(TC1270AL, TC1270ANL, TC1271AL
- 4.50V min./4.63V typ./4.75V max.).

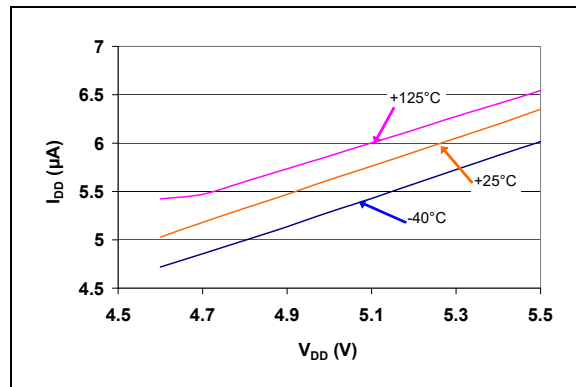

FIGURE 2-10: I_{DD} vs. V_{DD} (Reset Power-up Timer Active)
(TC1270AL, TC1270ANL, TC1271AL
- 4.50V min./4.63V typ./4.75V max.).

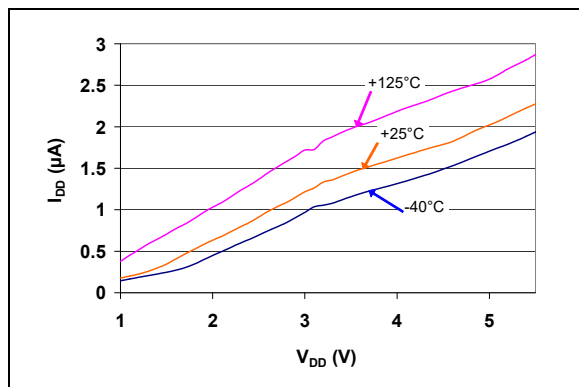

FIGURE 2-8: I_{DD} vs. V_{DD} (Reset Power-up Timer Inactive)
(TC1270AT, TC1270ANT, TC1271AT
- 3.00V min./3.08V typ./3.15V max.).

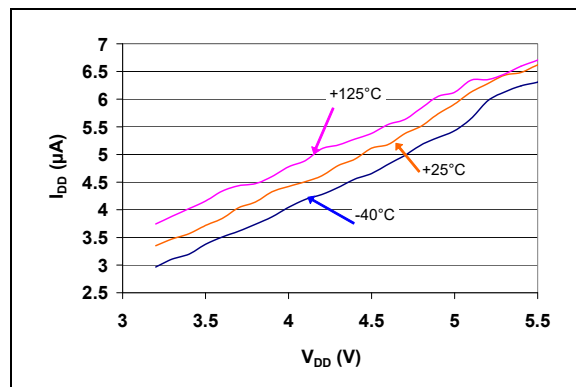

FIGURE 2-11: I_{DD} vs. V_{DD} (Reset Power-up Timer Active)
(TC1270AT, TC1270ANT, TC1271AT
- 3.00V min./3.08V typ./3.15V max.).

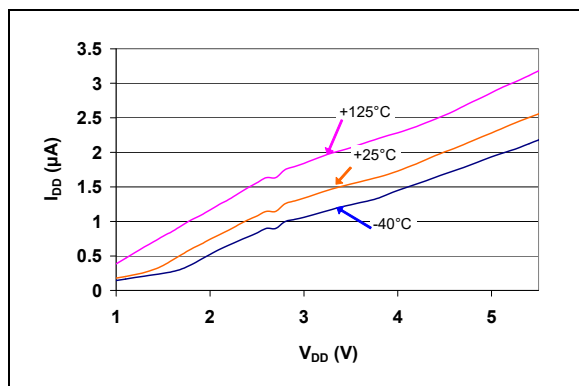

FIGURE 2-9: I_{DD} vs. V_{DD} (Reset Power-up Timer Inactive)
(TC1270AR, TC1270ANR, TC1271AR
- 2.55V min./2.63V typ./2.70V max.).

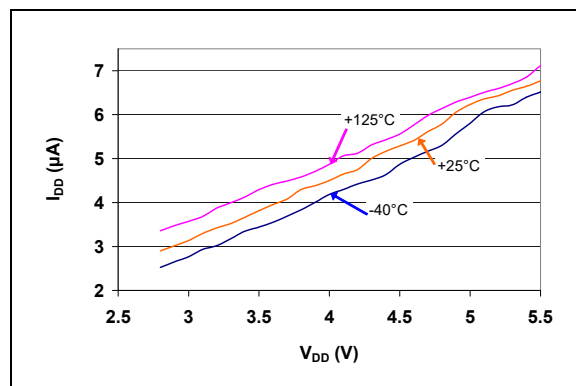

FIGURE 2-12: I_{DD} vs. V_{DD} (Reset Power-up Timer Active)
(TC1270AR, TC1270ANR, TC1271AR
- 2.55V min./2.63V typ./2.70V max.).

TC1270A/70AN/71A

Note: Unless otherwise indicated, all limits are specified for $V_{DD} = 1V$ to $5.5V$, $T_A = -40^{\circ}C$ to $+125^{\circ}C$.

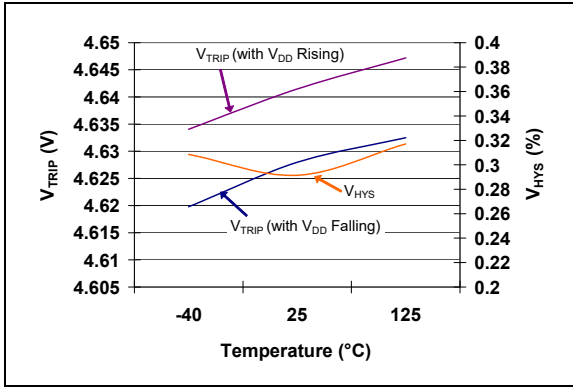

FIGURE 2-13: V_{TRIP} and V_{HYS} vs. Temperature
(TC1270AL, TC1270ANL, TC1271AL
- 4.50V min./4.63V typ./4.75V max.).

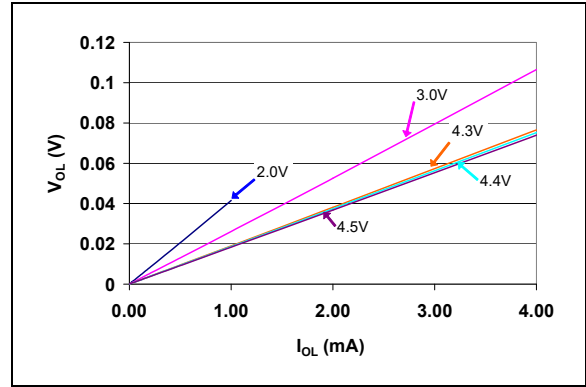

FIGURE 2-16: V_{OL} vs. I_{OL}
(TC1270AL, TC1270ANL, TC1271AL
- 4.50V min./4.63V typ./4.75V max.).

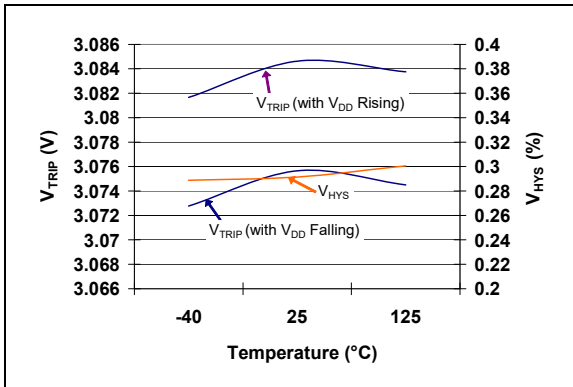

FIGURE 2-14: V_{TRIP} and V_{HYS} vs. Temperature
(TC1270AT, TC1270ANT, TC1271AT
- 3.00V min./3.08V typ./3.15V max.).

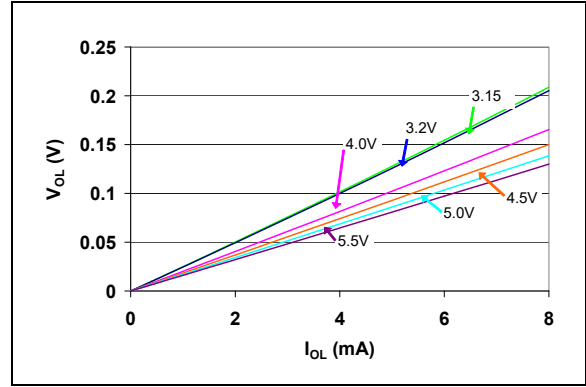

FIGURE 2-17: V_{OL} vs. I_{OL}
(TC1270AT, TC1270ANT, TC1271AT
- 3.00V min./3.08V typ./3.15V max.).

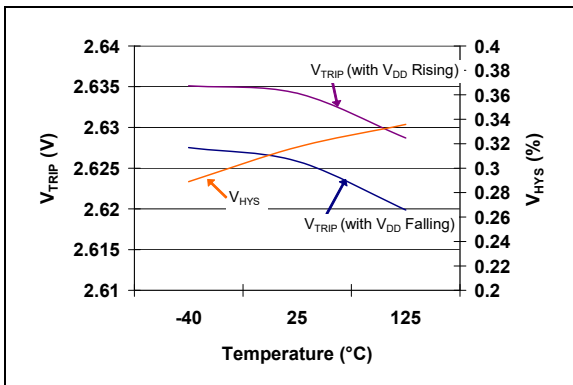

FIGURE 2-15: V_{TRIP} and V_{HYS} vs. Temperature
(TC1270AR, TC1270ANR, TC1271AR
- 2.55V min./2.63V typ./2.70V max.).

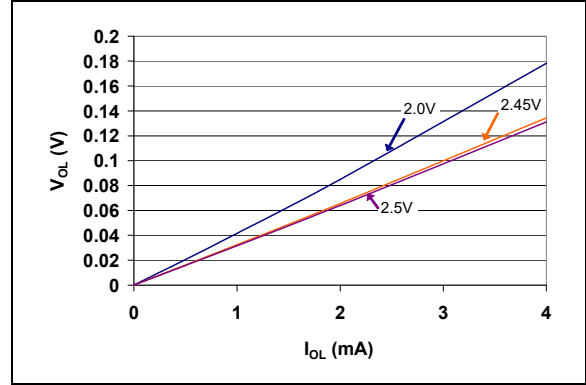

FIGURE 2-18: V_{OL} vs. I_{OL}
(TC1270AR, TC1270ANR, TC1271AR
- 2.55V min./2.63V typ./2.70V max.).

TC1270A/70AN/71A

Note: Unless otherwise indicated, all limits are specified for $V_{DD} = 1V$ to $5.5V$, $T_A = -40^{\circ}C$ to $+125^{\circ}C$.

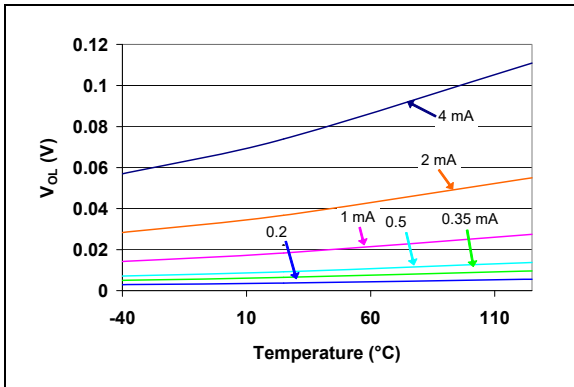

FIGURE 2-19: V_{OL} vs. Temperature
(TC1270AL, TC1270ANL, TC1271AL
- 4.50V min./4.63V typ./4.75V max.).
@ $V_{DD} = 4.5V$.

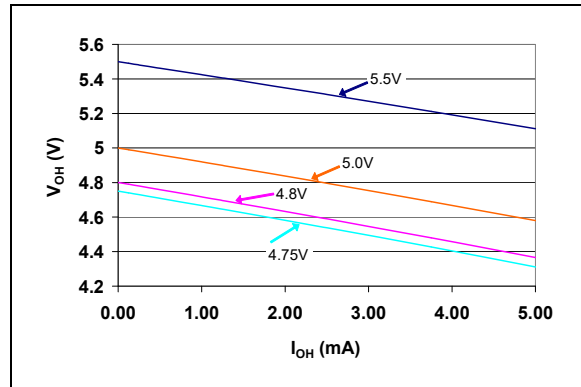

FIGURE 2-22: V_{OH} vs. I_{OH}
(TC1270AL, TC1270ANL, TC1271AL
- 4.50V min./4.63V typ./4.75V max.).
@ $+25^{\circ}C$.

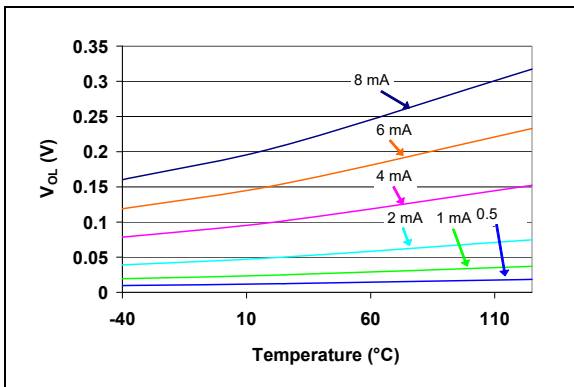

FIGURE 2-20: V_{OL} vs. Temperature
(TC1270AT, TC1270ANT, TC1271AT
- 3.00V min./3.08V typ./3.15V max.).
@ $V_{DD} = 2.7V$.

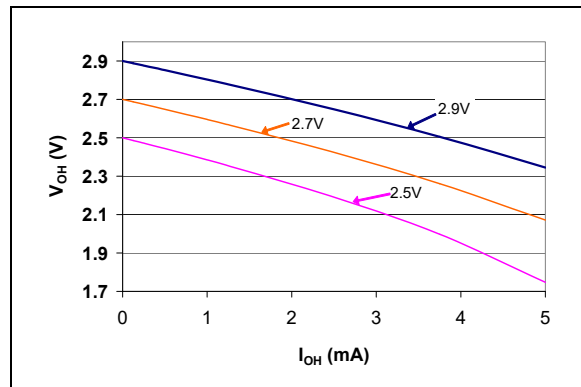

FIGURE 2-23: V_{OH} vs. I_{OH}
(TC1270AT, TC1270ANT, TC1271AT
- 3.00V min./3.08V typ./3.15V max.).
@ $+25^{\circ}C$.

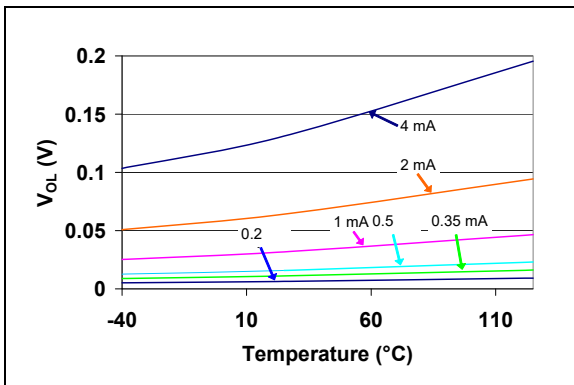

FIGURE 2-21: V_{OL} vs. Temperature
(TC1270AR, TC1270ANR, TC1271AR
- 2.55V min./2.63V typ./2.70V max.).
@ $V_{DD} = 1.8V$.

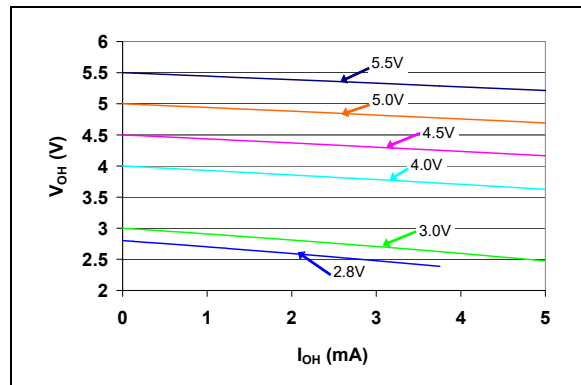

FIGURE 2-24: V_{OH} vs. I_{OH}
(TC1270AR, TC1270ANR, TC1271AR
- 2.55V min./2.63V typ./2.70V max.).
@ $+25^{\circ}C$.

TC1270A/70AN/71A

Note: Unless otherwise indicated, all limits are specified for $V_{DD} = 1V$ to $5.5V$, $T_A = -40^{\circ}C$ to $+125^{\circ}C$.

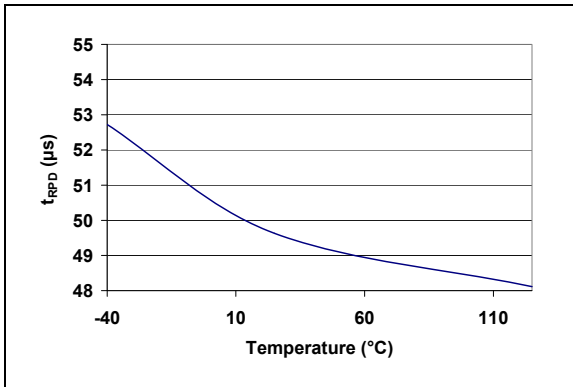

FIGURE 2-25: V_{DD} Falling to Reset Propagation Delay (t_{RPD}) vs. Temperature (TC1270AL, TC1270ANL, TC1271AL - 4.50V min./4.63V typ./4.75V max.).

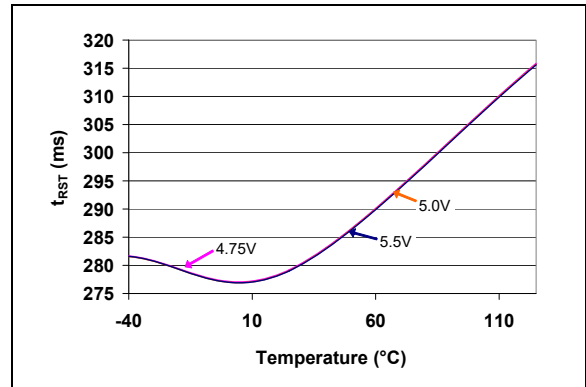

FIGURE 2-28: Reset Time-Out Period (t_{RST}) vs. Temperature (TC1270AL, TC1270ANL, TC1271AL - 4.50V min./4.63V typ./4.75V max.).

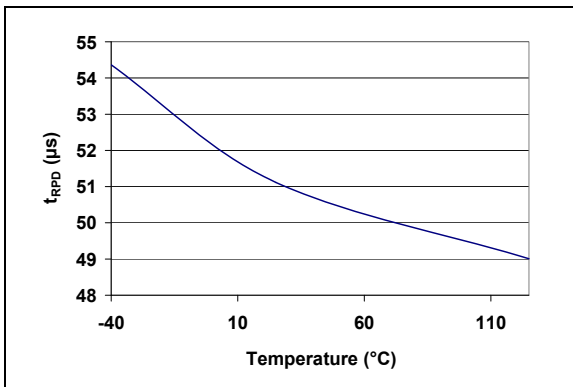

FIGURE 2-26: V_{DD} Falling to Reset Propagation Delay (t_{RPD}) vs. Temperature (TC1270AT, TC1270ANT, TC1271AT - 3.00V min./3.08V typ./3.15V max.).

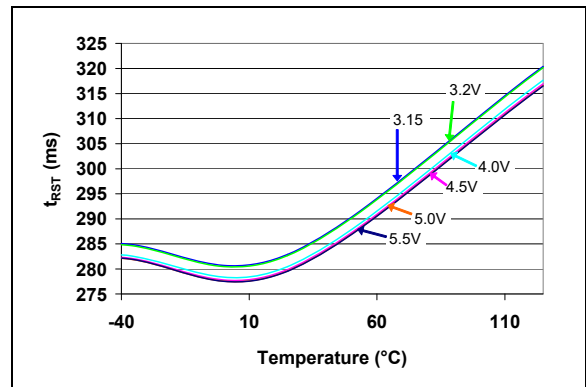

FIGURE 2-29: Reset Time-Out Period (t_{RST}) vs. Temperature (TC1270AT, TC1270ANT, TC1271AT - 3.00V min./3.08V typ./3.15V max.).

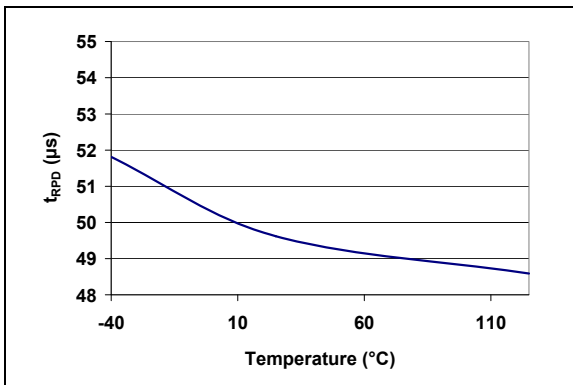

FIGURE 2-27: V_{DD} Falling to Reset Propagation Delay (t_{RPD}) vs. Temperature (TC1270AR, TC1270ANR, TC1271AR - 2.55V min./2.63V typ./2.70V max.).

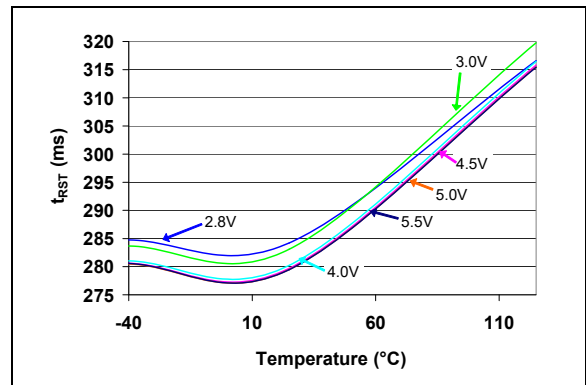

FIGURE 2-30: Reset Time-Out Period (t_{RST}) vs. Temperature (TC1270AR, TC1270ANR, TC1271AR - 2.55V min./2.63V typ./2.70V max.).

TC1270A/70AN/71A

Note: Unless otherwise indicated, all limits are specified for $V_{DD} = 1V$ to $5.5V$, $T_A = -40^{\circ}C$ to $+125^{\circ}C$.

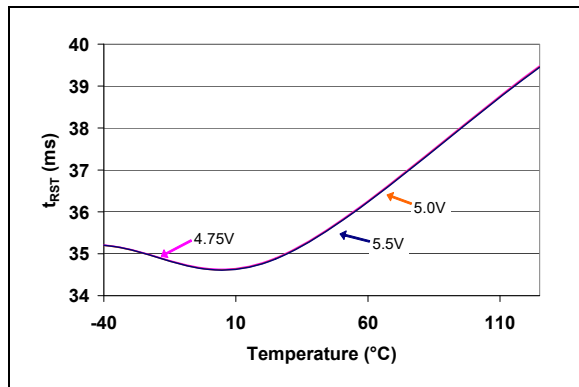

FIGURE 2-31: Reset Time-Out Period (t_{RST}) (C time out option) vs. Temperature (TC1270AL, TC1270ANL, TC1271AL - 4.50V min./4.63V typ./4.75V max.).

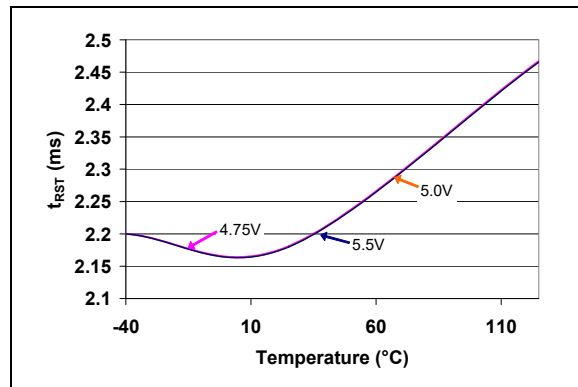

FIGURE 2-34: Reset Time-Out Period (t_{RST}) (B time out option) vs. Temperature (TC1270AL, TC1270ANL, TC1271AL - 4.50V min./4.63V typ./4.75V max.).

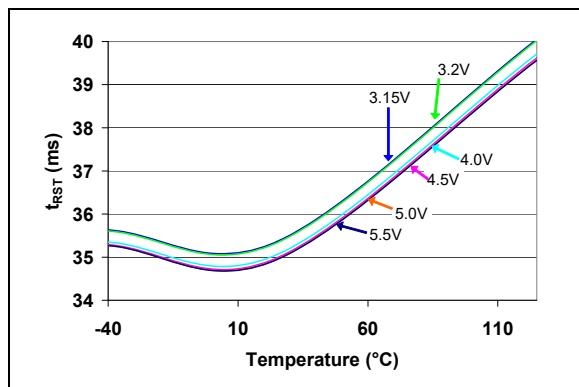

FIGURE 2-32: Reset Time-Out Period (t_{RST}) (C time out option) vs. Temperature (TC1270AT, TC1270ANT, TC1271AT - 3.00V min./3.08V typ./3.15V max.).

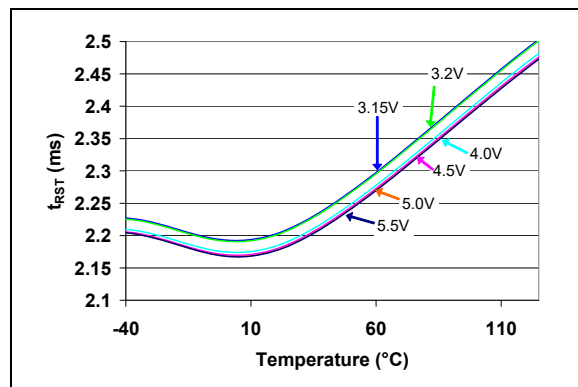

FIGURE 2-35: Reset Time-Out Period (t_{RST}) (B time out option) vs. Temperature (TC1270AT, TC1270ANT, TC1271AT - 3.00V min./3.08V typ./3.15V max.).

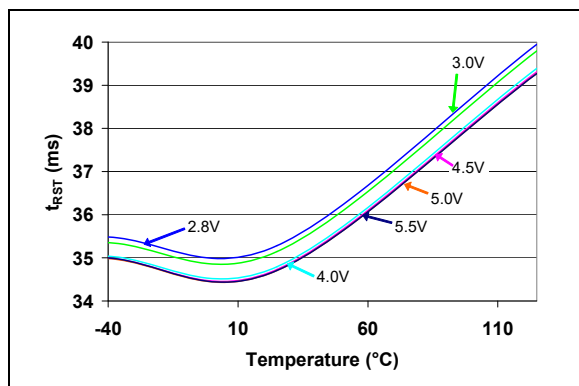

FIGURE 2-33: Reset Time-Out Period (t_{RST}) (C time out option) vs. Temperature (TC1270AR, TC1270ANR, TC1271AR - 2.55V min./2.63V typ./2.70V max.).

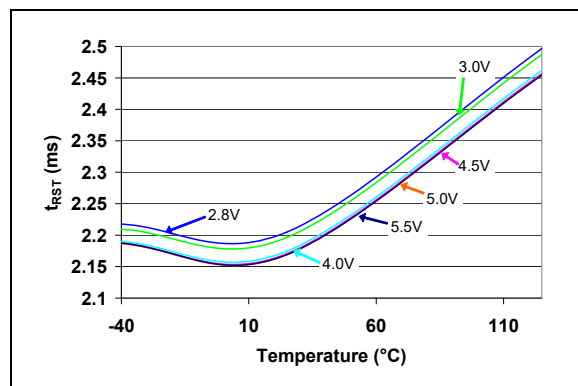

FIGURE 2-36: Reset Time-Out Period (t_{RST}) (B time out option) vs. Temperature (TC1270AR, TC1270ANR, TC1271AR - 2.55V min./2.63V typ./2.70V max.).

TC1270A/70AN/71A

Note: Unless otherwise indicated, all limits are specified for $V_{DD} = 1V$ to $5.5V$, $T_A = -40^{\circ}C$ to $+125^{\circ}C$.

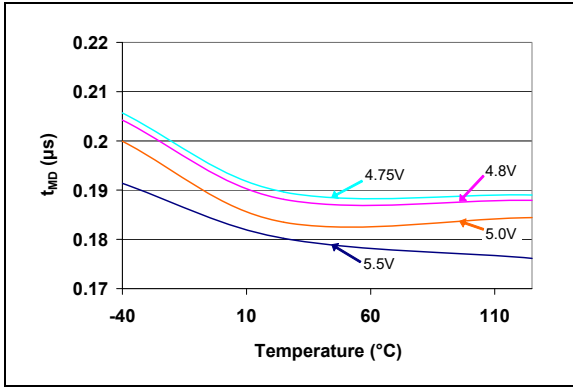

FIGURE 2-37: \overline{MR} Low to Reset Propagation Delay (t_{MD}) vs. Temperature (TC1270AL, TC1270ANL, TC1271AL - 4.50V min./4.63V typ./4.75V max.).

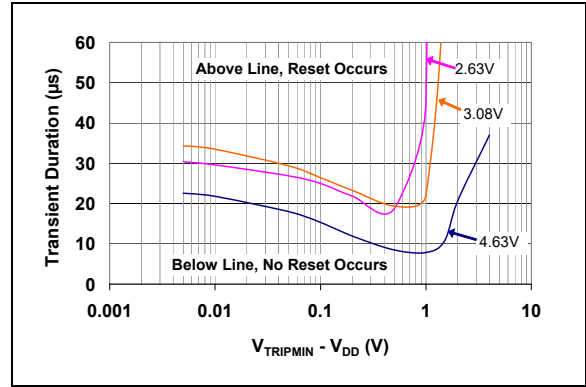

FIGURE 2-40: V_{DD} Transient Duration vs. Reset Threshold Overdrive (V_{TRIP} (minimum) - V_{DD}).

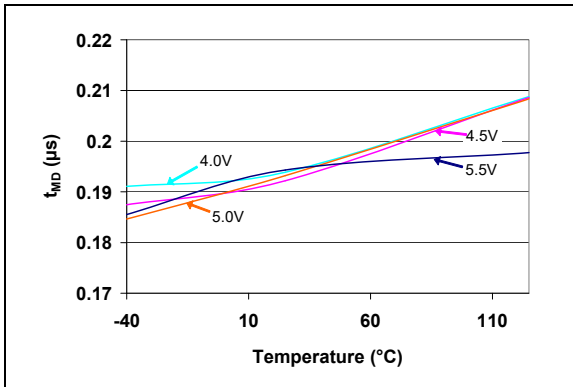

FIGURE 2-38: \overline{MR} Low to Reset Propagation Delay (t_{MD}) vs. Temperature (TC1270AT, TC1270ANT, TC1271AT - 3.00V min./3.08V typ./3.15V max.).

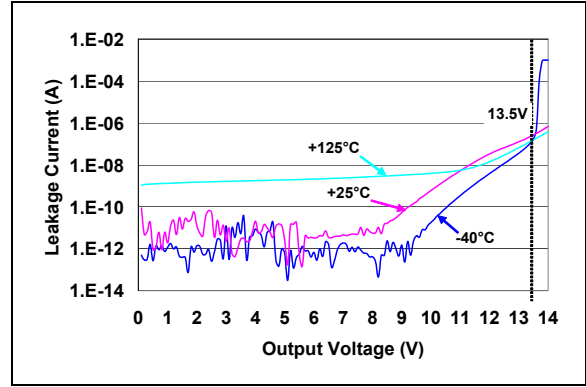

FIGURE 2-41: Open-Drain Leakage Current vs. Voltage Applied to RST Pin (TC1270AR, TC1270ANR, TC1271AR - 2.55V minimum).

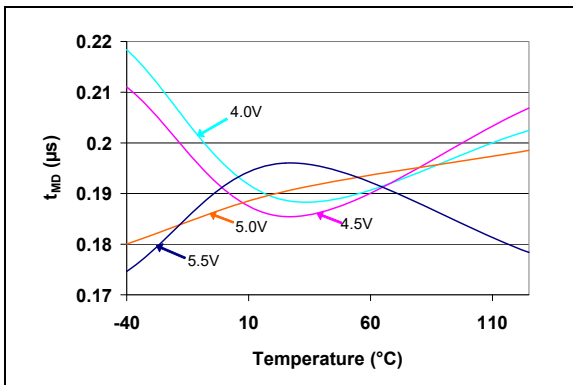

FIGURE 2-39: \overline{MR} Low to Reset Propagation Delay (t_{MD}) vs. Temperature (TC1270AR, TC1270ANR, TC1271AR - 2.55V min./2.63V typ./2.70V max.).

TC1270A/70AN/71A

NOTES:

3.0 PIN DESCRIPTIONS

Descriptions of the pins are listed in [Table 3-1](#).

TABLE 3-1: PINOUT DESCRIPTION

Pin Number						Sym	Pin		Standard Function
TC1270A (Push-Pull, active-low)		TC1270AN (Open-Drain, active-low)		TC1271A (Push-Pull, active-high)			Type	Buffer / Driver	
SOT-23-5	SOT-143-4	SOT-23-5	SOT-143-4	SOT-23-5	SOT-143-4				
5	1		1	5	1	V_{SS}	—	Power	Ground
4	2	—	—	—	—	RST	O	Push-Pull	Reset output (Push-Pull), active-low $H = V_{DD} > V_{TRIP}$, Reset pin is inactive (after Reset Delay Timer completes) $L = V_{DD} < V_{TRIP}$, Reset pin is active Goes active (Low) if one of these conditions occurs: <ol style="list-style-type: none"> If V_{DD} falls below the selected Reset voltage threshold. If the \overline{MR} pin is forced low. During power-up.
—	—	4	2	—	—	\overline{RST}	O	Open-Drain	Reset output (Open-Drain), active-low $Float = V_{DD} > V_{TRIP}$, Reset pin is inactive (after Reset Delay Timer completes) $L = V_{DD} < V_{TRIP}$, Reset pin is active Goes active (Low) if one of these conditions occurs: <ol style="list-style-type: none"> If V_{DD} falls below the selected Reset voltage threshold. If the \overline{MR} pin is forced low. During power-up.
—	—	—	—	4	2	RST	O	Push-Pull	Reset output (Push-Pull), active-high $H = V_{DD} < V_{TRIP}$, Reset pin is active $L = V_{DD} > V_{TRIP}$, Reset pin is inactive (after Reset Delay Timer completes) Goes active (High) if one of these conditions occurs: <ol style="list-style-type: none"> If V_{DD} falls below the selected Reset voltage threshold. If the \overline{MR} pin is forced low. During power-up.

Note 1: The \overline{MR} pin has an internal weak pull-up (18.5 k Ω typical).

TC1270A/70AN/71A

TABLE 3-1: PINOUT DESCRIPTION (CONTINUED)

Pin Number						Sym	Pin		Standard Function
TC1270A (Push-Pull, active-low)		TC1270AN (Open-Drain, active-low)		TC1271A (Push-Pull, active-high)			Type	Buffer/ Driver	
SOT-23-5	SOT-143-4	SOT-23-5	SOT-143-4	SOT-23-5	SOT-143-4				
3	3	3	3	3	3	$\overline{\text{MR}}$	I	ST ⁽¹⁾	Manual Reset Input Pin This input allows a push button switch to be directly connected to a TC1270A/70AN/71A device's $\overline{\text{MR}}$ pin, which can be used to force a system Reset. The input filter ignores noise pulses that occur on the $\overline{\text{MR}}$ pin. H = Switch is open (internal pull-up resistor pulls signal high). State of the $\text{RST}/\overline{\text{RST}}$ pin is determined by other system conditions. L = Switch is depressed (shorted to ground). This forces the $\text{RST}/\overline{\text{RST}}$ pin Active.
2	4	2	4	2	4	V_{DD}	—	Power	Supply Voltage
1	—	1	—	1	—	NC	—	—	No Connection

Note 1: The $\overline{\text{MR}}$ pin has an internal weak pull-up (18.5 k Ω typical).

3.1 Ground Terminal (V_{SS})

V_{SS} provides the negative reference for the analog input voltage. Typically, the circuit ground is used.

3.2 Supply Voltage (V_{DD})

V_{DD} can be used for power supply monitoring or a voltage level that requires monitoring.

3.3 Reset Output (RST and $\overline{\text{RST}}$)

There are three types of Reset output pins. These are:

1. Push-Pull active-low Reset
2. Push-Pull active-high Reset
3. Open-Drain active-low Reset, external pull-up resistor required.

3.3.1 ACTIVE-LOW ($\overline{\text{RST}}$) – PUSH-PULL

The $\overline{\text{RST}}$ push-pull output remains low while V_{DD} is below the Reset voltage threshold (V_{TRIP}). The time that the $\overline{\text{RST}}$ pin is held low after the device voltage (V_{DD}) returns to a high level ($> V_{\text{TRIP}}$) is typically 280 ms. After the Reset Delay Timer expires, the $\overline{\text{RST}}$ pin will be driven to the high state.

3.3.2 ACTIVE-HIGH (RST) – PUSH-PULL

The RST push-pull output remains high while V_{DD} is below the Reset voltage threshold (V_{TRIP}). The time that the RST pin is held high after the device voltage (V_{DD}) returns to a high level ($> V_{\text{TRIP}}$) is typically 280 ms. After the Reset Delay Timer expires, the RST pin will be driven to the low state.

3.3.3 ACTIVE-LOW ($\overline{\text{RST}}$) – OPEN-DRAIN

The $\overline{\text{RST}}$ open-drain output remains low while V_{DD} is below the Reset voltage threshold (V_{TRIP}). The time that the $\overline{\text{RST}}$ pin is held low after the device voltage (V_{DD}) returns to a high level ($> V_{\text{TRIP}}$) depends on the Reset time-out selected. After the Reset Delay Timer expires, the $\overline{\text{RST}}$ pin will float.

3.4 Manual Reset Input ($\overline{\text{MR}}$)

The Manual Reset ($\overline{\text{MR}}$) input pin allows a push button switch to easily be connected to the system. When the push button is depressed, it forces a system Reset. This pin has circuitry that filters noise that may be present on the $\overline{\text{MR}}$ signal.

The $\overline{\text{MR}}$ pin is active-low and has an internal pull-up resistor.

4.0 DEVICE OPERATION

4.1 General Description

For many of today's microcontroller applications, care must be taken to prevent low-power conditions that can cause many different system problems. The most common causes are brown-out conditions, where the system supply drops below the operating level momentarily. The second most common cause is when a slowly decaying power supply causes the microcontroller to begin executing instructions without sufficient voltage to sustain volatile memory (RAM), thus producing indeterminate results.

The TC127XA family (TC1270A, TC1270AN and TC1271A) are cost-effective voltage supervisor devices designed to keep a microcontroller in Reset until the system voltage has reached and stabilized at the proper level for reliable system operation. These devices also operate as protection from brown-out conditions when the system supply voltage drops below a safe operating level.

A Manual Reset input ($\overline{\text{MR}}$ pin) is provided. This allows a push button switch to be directly connected to the TC127XA device, and is suitable for use as a push button Reset. This allows the system to easily be reset from the external control of the push button switch. No external components are required.

The Reset pin ($\overline{\text{RST}}$ or $\overline{\text{RST}}$) will be forced active, if any of the following occur:

- During device power-up
- V_{DD} goes below the device threshold voltage
- The Manual Reset input ($\overline{\text{MR}}$) goes low

Figure 4-1 shows a high level block diagram of the devices. The device can be described with three functional blocks. These are:

- Voltage detect circuit
- Manual Reset with glitch filter circuit
- Reset generator circuit

The Reset generator circuit controls the Reset delay time of the Reset output signal.

There are three Reset Delay Timer options. Depending on the option, the Reset signal ($\overline{\text{RST}}$ / $\overline{\text{RST}}$ pin) will be held active for a minimum of 1.09 ms, 17.5 ms, or 140 ms.

The TC1271A has an active-high $\overline{\text{RST}}$ output while the TC1270A and TC1270AN have an active-low $\overline{\text{RST}}$ output.

The TC1270A and TC1271A have a push-pull output driver, while the TC1270AN has an open-drain output.

Figure 4-2 shows a typical circuit for a push-pull device and Figure 4-3 shows a typical circuit for an open-drain device.

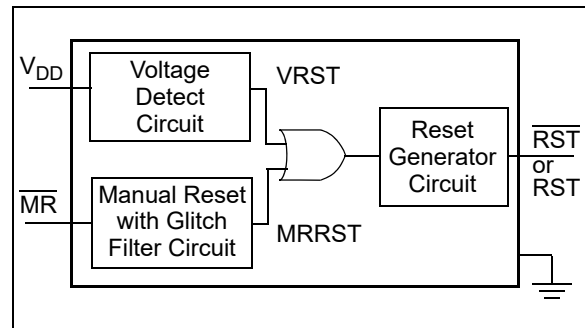

FIGURE 4-1: TC127XA High Level Block Diagram.

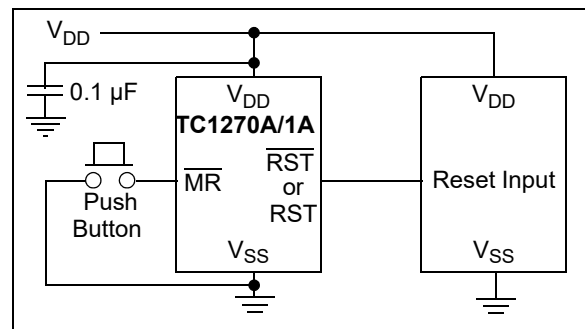

FIGURE 4-2: Typical Push-Pull Application Circuit.

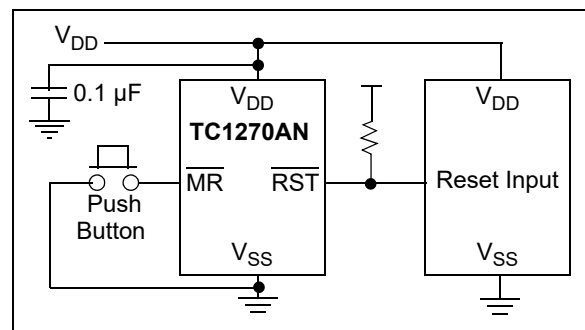

FIGURE 4-3: Typical Open-Drain Application Circuit.

The TC1270A and TC1271A devices are available in a 4-Pin SOT-143 package (to maintain footprint compatibility with the TC1270, TC1271, TCM811 and TCM812 devices) and a SOT-23-5 package. The TC1270AN is only available in the SOT-23-5 package.

Low supply current makes these devices suitable for battery-powered applications.

Device specific block diagrams are presented in Figure 4-4 through Figure 4-6.

TC1270A/70AN/71A

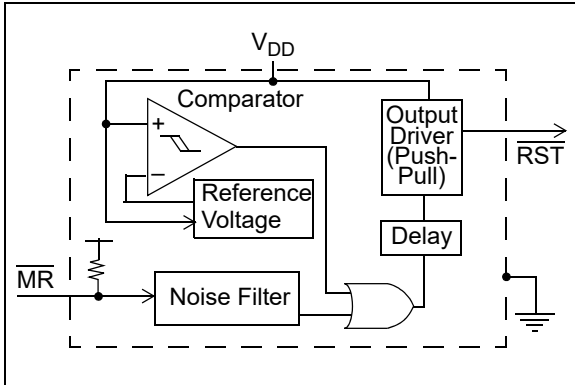

FIGURE 4-4: TC1270A Block Diagram.

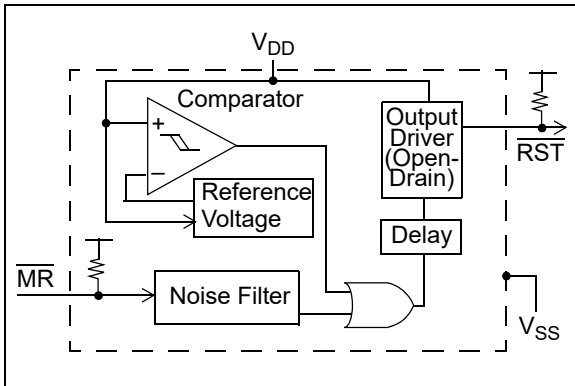

FIGURE 4-5: TC1270AN Block Diagram.

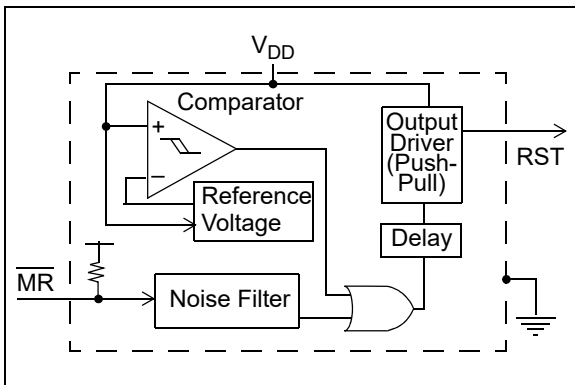

FIGURE 4-6: TC1271A Block Diagram.

4.2 Voltage Detect Circuit

The voltage detect circuit monitors V_{DD} . The device's Reset voltage trip point (V_{TRIP}) is selected when the device is ordered. The voltage on the device's V_{DD} pin determines the output state of the \overline{RST}/RST pin.

V_{DD} voltages above the $V_{TRIP(MAX)}$ force the \overline{RST}/RST pin inactive. V_{DD} voltages below the $V_{TRIP(MIN)}$ force the \overline{RST}/RST pin active. The state of the \overline{RST}/RST pin is unknown for V_{DD} voltages between $V_{TRIP(MAX)}$ and $V_{TRIP(MIN)}$. This is shown in Table 4-1

TABLE 4-1: V_{DD} LEVELS TO \overline{RST}/RST OUTPUT STATES

V_{DD} Voltage Level	Output State	
	\overline{RST}	RST
$V_{DD} \geq V_{TRIP(MAX)}$	H ^(1, 2)	L ⁽¹⁾
$V_{TRIP(MIN)} < V_{DD} < V_{TRIP(MAX)}$	U	U
$V_{DD} \leq V_{TRIP(MIN)}$	L	H

Legend: H = Driven High, L = Driven Low, U = Unknown, driven either High or Low

Note 1: The \overline{RST}/RST pin will be driven inactive after the Reset Delay Timer (t_{RST}) times out.

Note 2: The TC1270AN \overline{RST} pin will be floated after the Reset Delay Timer (t_{RST}) times out.

The term V_{TRIP} will be used as the general term for the trip point voltage where the device actually trips.

In the case where V_{DD} is falling (for voltages starting above $V_{TRIP(MAX)}$):

- Voltages above $V_{TRIP(MAX)}$ will never cause the \overline{RST}/RST output pin to be driven active.
- Voltages below $V_{TRIP(MIN)}$ will always cause the \overline{RST}/RST output pin to be driven active.

In the case where V_{DD} is rising (for voltages starting below $V_{TRIP(MIN)}$):

- Voltages above $V_{TRIP(MAX)}$ will always cause the \overline{RST}/RST output pin to be driven inactive, (or floated, in the TC1270AN) after the Reset Delay Timer (t_{RST}), times out.

Table 4-2 shows the various device trip point options and their $V_{TRIP(MAX)}$ and $V_{TRIP(MIN)}$ voltages. The negative percentage change from common regulated voltages is also shown.

If the V_{DD} is falling from the regulated voltage as it crosses the V_{TRIP} voltage, the \overline{RST}/RST pin is driven active. Then, the desired circuitry is forced into Reset, or the circuitry has the indication that the V_{DD} is below the selected V_{TRIP} .

If the V_{DD} is rising as it crosses the V_{TRIP} voltage, the \overline{RST}/RST pin is driven inactive after the Reset Delay Timer elapses. Then, the desired circuitry is released from Reset and will start to operate in its Normal mode, or the circuitry has the indication that the V_{DD} is above the selected V_{TRIP} .

TABLE 4-2: SELECTING THE TRIP POINT

Trip Voltage Selection	$V_{TRIP(MAX)}^{(1)}$ / $V_{TRIP(MIN)}^{(2)}$	- % From Regulated Voltage		
		5.0V	3.3V	3.0V
L	4.75V	5.0%	—	—
	4.50V	10.0%	—	—
M	4.50V	10.0%	—	—
	4.25V	15.0%	—	—
T	3.15V	—	4.5%	—
	3.00V	—	9.2%	—
S	3.00V	—	9.2%	—
	2.85V	—	13.7%	—
R	2.70V	—	—	10.0%
	2.55V	—	—	15.0%

- Note 1:** Voltage regulator circuit must have tighter tolerance (%) than $V_{TRIP(MAX)}$ % from regulated voltage.
- 2:** Circuitry being reset must have a wider tolerance (%) than $V_{TRIP(MIN)}$ % from regulated voltage.

The TC1270A/TC1270AN/TC1271A devices are optimized to reject fast transient glitches on the V_{DD} line. If the low input signal (which is below V_{TRIP}) is not rejected, the Reset output is driven active within 50 μ s of V_{DD} falling through the Reset voltage threshold.

After the device exits the Reset condition, the delay circuitry will hold the \overline{RST}/RST pin active until the appropriate Reset delay time (t_{RST}) has elapsed.

During device power-up, the input voltage is below the trip point voltage. The device must enter the valid operating range for the device to start operation.

4.2.1 HYSTERESIS

There is also a minimal hysteresis (V_{HYS}) on the trip point. This is so that small noise signals on the device voltage (V_{DD}) do not cause the Reset pin (\overline{RST}/RST) to “jitter” (oscillate between active and inactive levels).

The characterization graphs shown in Figures 2-13 through 2-15 show the device hysteresis as a percentage of the voltage trip point (V_{TRIP}).

The Reset Delay Timer (t_{RST}) gives a time-based hysteresis for the system.

4.2.2 POWER-UP/RISING V_{DD}

As the device V_{DD} rises, the device’s Reset circuit will remain active until the voltage rises above the “actual” trip point (V_{TRIP}).

Figure 4-7 shows a power-up sequence and the waveform of the \overline{RST} and RST pins. As the device powers up, the voltage will start below the valid operating voltage of the device. At this voltage, the \overline{RST}/RST output is not valid. Once the voltage is above the minimum operating voltage (1V) and below the selected V_{TRIP} , the Reset output will be active.

Once the device voltage rises above the V_{TRIP} voltage, the Reset Delay Timer (t_{RST}) starts. When the Reset Delay Timer times out, the Reset output (\overline{RST}/RST) is driven inactive.

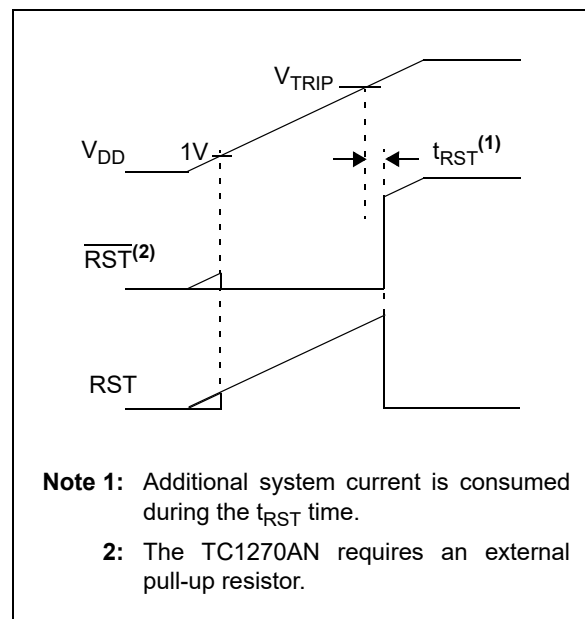

FIGURE 4-7: \overline{RST}/RST Pin Operation Power-up.

TC1270A/70AN/71A

4.2.3 POWER-DOWN/BROWN-OUT

As the device powers-down/browns-out, the V_{DD} falls from a voltage above the devices trip point (V_{TRIP}). The device will trip at a voltage between the maximum trip point ($V_{TRIP(MAX)}$) and the minimum trip point ($V_{TRIP(MIN)}$). Once the device voltage (V_{DD}) goes below this voltage, the \overline{RST}/RST pin will be forced to the active state. Table 4-3 shows the state of the \overline{RST} or RST pins.

Figure 4-8 shows the waveform of the \overline{RST} pin as determined by the V_{DD} voltage. As the V_{DD} voltage falls from the normal operating point, the device “enters” Reset by crossing the V_{TRIP} voltage (between $V_{TRIP(MAX)}$ and $V_{TRIP(MIN)}$). Then, when V_{DD} voltage rises, the device “exits” Reset by crossing the V_{TRIP} voltage (below, or at, $V_{TRIP(MAX)}$). After the “exit” state has been detected, the Reset Delay Timer (t_{RST}) starts. When the t_{RST} time completes, the Reset pin is driven inactive.

TABLE 4-3: RESET PIN STATES

Device	State of \overline{RST} Pin when:		State of RST Pin when:		Output Driver
	$V_{DD} < V_{TRIP}$	$V_{DD} > V_{TRIP}^{(1)}$	$V_{DD} < V_{TRIP}$	$V_{DD} > V_{TRIP}^{(1)}$	
TC1270A	L	H	—	—	Push-Pull
TC1271A	—	—	H	L	Push-Pull

Note 1: The \overline{RST}/RST pin will be driven inactive after the Reset Delay Timer (t_{RST}) times out.

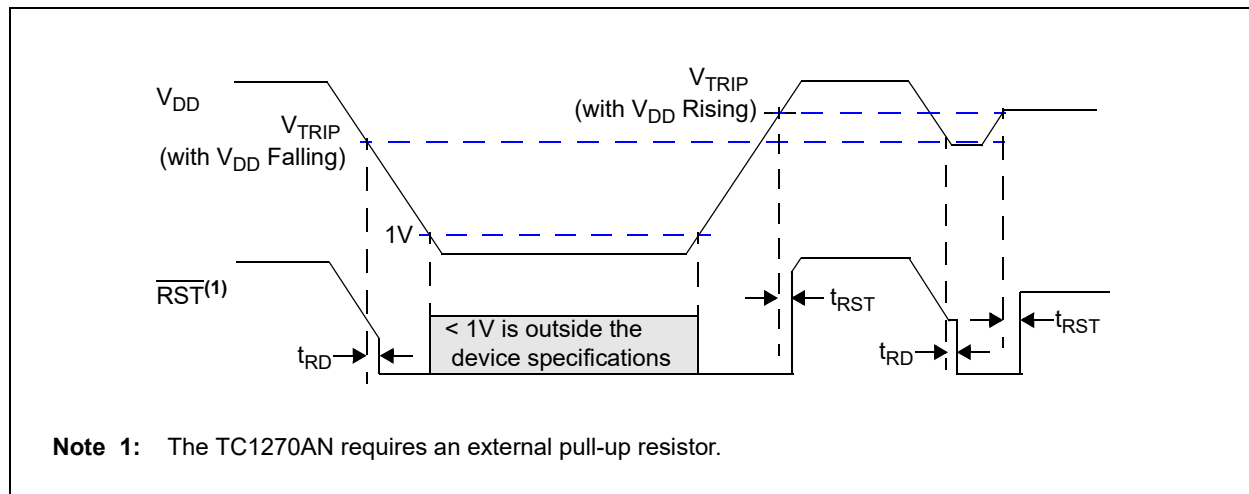

FIGURE 4-8: \overline{RST} Operation as determined by the V_{TRIP} .

4.3 Negative-Going V_{DD} Transients

The minimum pulse width (time) required to cause a Reset may be an important criteria in the implementation of a Power-on Reset (POR) circuit. This time is referred to as transient duration. The TC127XA devices are designed to reject a level of negative-going transients (glitches) on the power supply line.

Transient duration is the amount of time needed for these supervisory devices to respond to a drop in V_{DD} . The transient duration time (t_{TRAN}) is dependent on the magnitude of $V_{TRIP} - V_{DD}$ (overdrive). Any combination of duration and overdrive that lies under the duration/overdrive curve will not generate a Reset signal. Generally speaking, the transient duration time decreases with an increase in the $V_{TRIP} - V_{DD}$ voltage.

Figure 4-9 shows an example transient duration vs. Reset comparator overdrive. It shows that the farther below the trip point the transient pulse goes, the shorter the duration of the pulse required to cause a Reset gets. So, any combination of duration and overdrive that lays **under** the curve will **not** generate a Reset signal. Combinations **above** the curve are detected as a brown-out or power-down.

Transient immunity can be improved by adding a bypass capacitor (typically 0.1 μF) as close as possible to the V_{DD} pin of the TC127XA device.

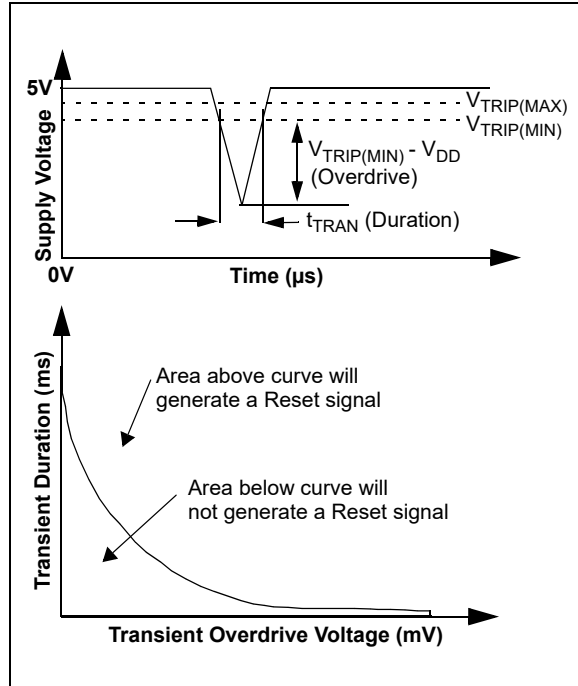

FIGURE 4-9: Example of Typical Transient Duration Waveform.

4.4 Manual Reset with Glitch Filter Circuit

The Manual Reset input pin ($\overline{\text{MR}}$) allows the Reset pins ($\text{RST}/\overline{\text{RST}}$) to be manually forced to their active states. The $\overline{\text{MR}}$ pin has circuitry to filter noise pulses that may be present on the pin. Figure 4-10 shows a block diagram for using the TC127XA with a push button switch. To minimize the required external components, the $\overline{\text{MR}}$ input has an internal pull-up resistor.

A mechanical push button or active logic signal can drive the $\overline{\text{MR}}$ input.

Once $\overline{\text{MR}}$ has been low for a time, t_{MD} (the manual Reset delay time), the Reset output pins are forced active. The Reset output pins will remain in their active states for the Reset Delay Timer time-out period (t_{RST}).

Figure 4-11 shows a waveform for the manual Reset switch input and the Reset pins output.

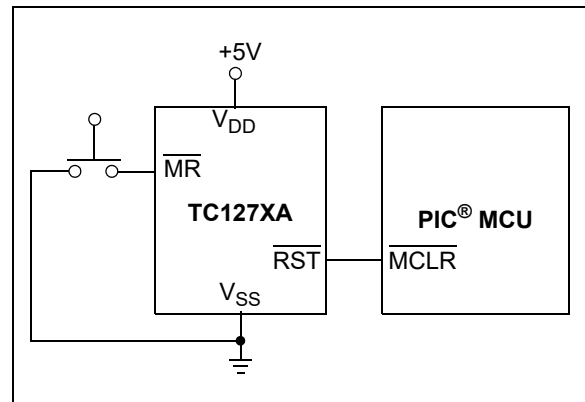

FIGURE 4-10: Push Button Reset.

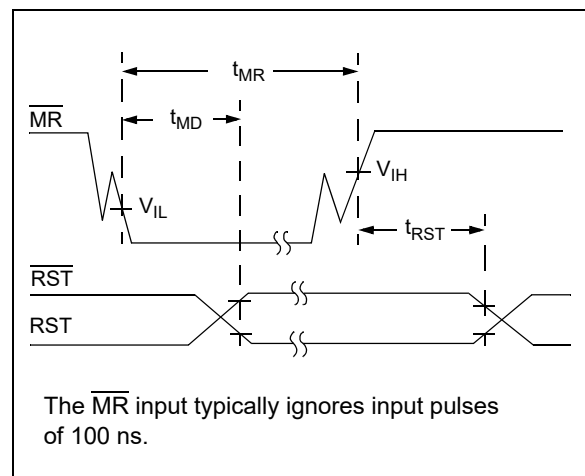

FIGURE 4-11: $\overline{\text{MR}}$ Input – Push Button.

4.4.1 NOISE FILTER

The noise filter filters out noise spikes (glitches) on the Manual Reset pin ($\overline{\text{MR}}$). Noise spikes less than 100 ns (typical) are filtered.

TC1270A/70AN/71A

4.5 Reset Generator Circuit

The output signals from the voltage detect circuit and the manual Reset with glitch filter circuit are OR'd together and used to activate the Reset generator module.

After the Reset conditions have been removed (the \overline{MR} pin is no longer forced low and the input voltage is greater than the trip point voltage), the Reset generator circuit determines the Reset delay time-out required.

There are three options for the delay circuit. These are:

- 2.19 ms (typical) delay
- 35 ms (typical) delay
- 280 ms (typical) delay

4.5.1 RESET DELAY TIMER

The Reset Delay Timer ensures that the TC127XA device will "hold" the embedded system in Reset until the system voltage has stabilized. The Reset Delay Timer time-out is shown in [Table 4-4](#).

The Reset Delay Timer starts when the voltage detect circuit output AND the manual Reset with glitch filter circuit output become inactive. While the Reset Delay Timer is active, the \overline{RST} or RST pin is driven to the active state. When the Reset Delay Timer times out, the \overline{RST} or RST pin is driven inactive.

The Reset Delay Timer (t_{RST}) starts after the device voltage rises above the "actual" trip point (V_{TRIP}). When the Reset Delay Timer times out, the Reset output pin (\overline{RST}/RST) is driven inactive.

The Reset Delay Timer is cleared if either, or both, the voltage detector circuit output and the manual Reset with glitch filter circuit output become active. The \overline{RST} or RST pin continues to be driven to the active state.

[Figure 4-12](#) illustrates when the Reset Delay Timer (t_{RST}) is active or inactive.

4.5.2 EFFECT OF TEMPERATURE ON RESET POWER-UP TIMER (t_{RPU})

The Reset Delay Timer time-out period (t_{RST}) determines how long the device remains in the Reset condition. This time out is affected by the device V_{DD} and the temperature. Typical responses for varying V_{DD} values and temperatures are presented in [Figures 2-28](#), [2-29](#) and [2-30](#).

TABLE 4-4: RESET DELAY TIMER TIME OUTS

t_{RST}			Units
Min	Typ	Max	
1.09	2.19	4.38	ms
17.5	35	70	ms
140	280	560	ms
↑		↑	
This is the minimum time that the Reset Delay Timer will "hold" the Reset pin active after V_{DD} rises above V_{TRIP}		This is the maximum time that the Reset Delay Timer will "hold" the Reset pin active after V_{DD} rises above V_{TRIP}	

Note 1: Shaded rows are custom-ordered time outs.

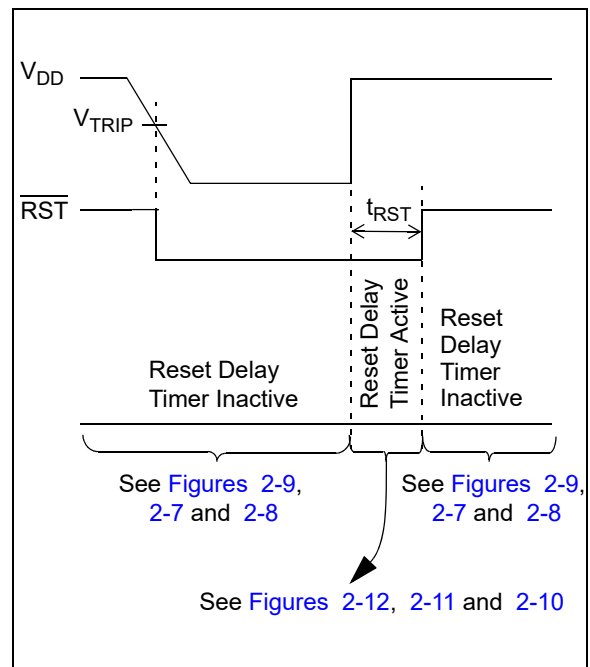

FIGURE 4-12: Reset Power-up Timer Waveform.

5.0 APPLICATION INFORMATION

This section presents application-related information that may be useful for your particular design requirements.

5.1 Supply Monitor Noise Sensitivity

The TC127XA devices are optimized for fast responses to negative-going changes in V_{DD} . A system with an inordinate amount of electrical noise on V_{DD} (such as a system using relays) may require a 0.01 μF or 0.1 μF bypass capacitor to reduce detection sensitivity. This capacitor should be installed as close to the TC127XA as possible to keep the capacitor lead length short.

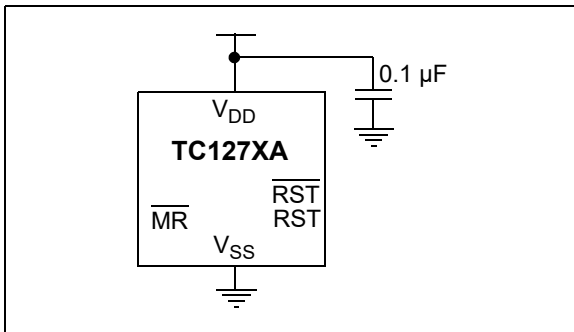

FIGURE 5-1: Typical Application Circuit with Bypass Capacitor.

5.2 Conventional Voltage Monitoring

Figure 5-2 and Figure 5-3 show the TC127XA in conventional voltage monitoring applications.

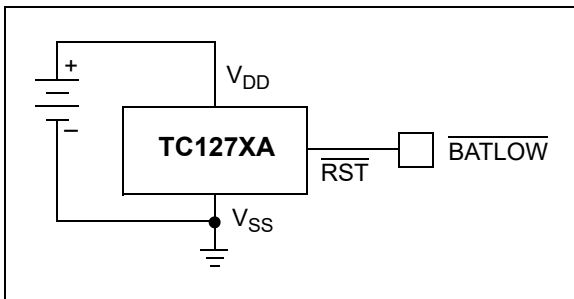

FIGURE 5-2: Battery Voltage Monitor.

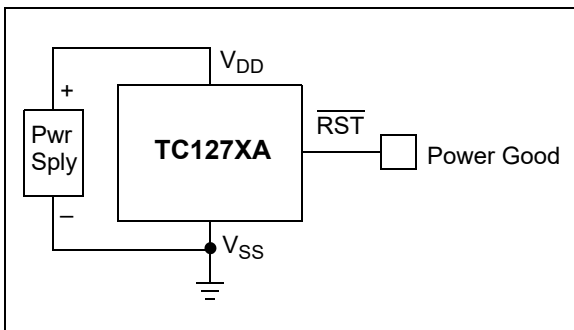

FIGURE 5-3: Power Good Monitor.

5.3 Using in PIC[®] Microcontroller, ICSP[™] Applications

Note: This operation can only be done using the device that has an Open-Drain RST pin (TC1270AN).

Figure 5-4 shows the typical application circuit for using the TC1270AN for voltage supervisory function when the PIC microcontroller will be programmed via the In-Circuit Serial Programming[™] (ICSP[™]) feature. Additional information is available in the Microchip Technical Brief TB087, "Using Voltage Supervisors with PICmicro[®] Microcontroller Systems which Implement In-Circuit Serial Programming[™]" (DS91087).

Note: It is recommended that the current into the RST pin is current that is limited by a 1 k Ω resistor.

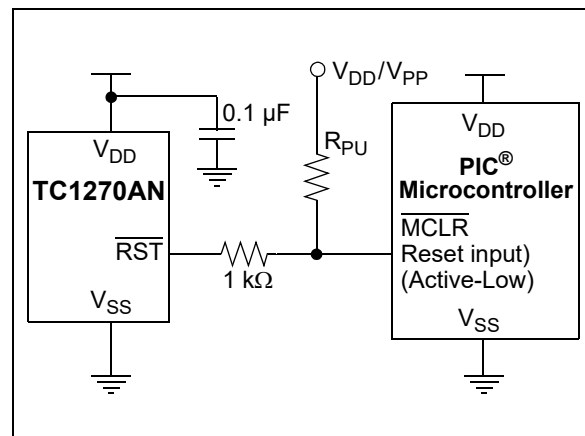

FIGURE 5-4: Typical Application Circuit for PIC Microcontroller with the ICSP Feature.

TC1270A/70AN/71A

5.4 Modifying The Trip Point, V_{TRIP}

Although the TC127XA device has a fixed voltage trip point (V_{TRIP}), it can be necessary to make custom adjustments. This is accomplished by connecting an external resistor divider to the TC127XA V_{DD} pin. This causes the V_{SOURCE} voltage to be higher than it is when the TC127XA input equals its V_{TRIP} voltage (Figure 5-5).

To maintain detector accuracy, the bleeder current through the divider should be significantly higher than the 15 μ A maximum operating current required by the TC127XA. A reasonable value for this bleeder current is 1 mA (67 times the 10 μ A required by the TC127XA). For example, if $V_{TRIP} = 2V$ and the desired trip point is 2.5V, the value of $R_1 + R_2$ is 2.5 k Ω (2.5V/1 mA). The value of $R_1 + R_2$ can be rounded to the nearest standard value and plugged into the equation shown in Figure 5-5 to calculate values for R_1 and R_2 .

1% tolerance resistors are recommended.

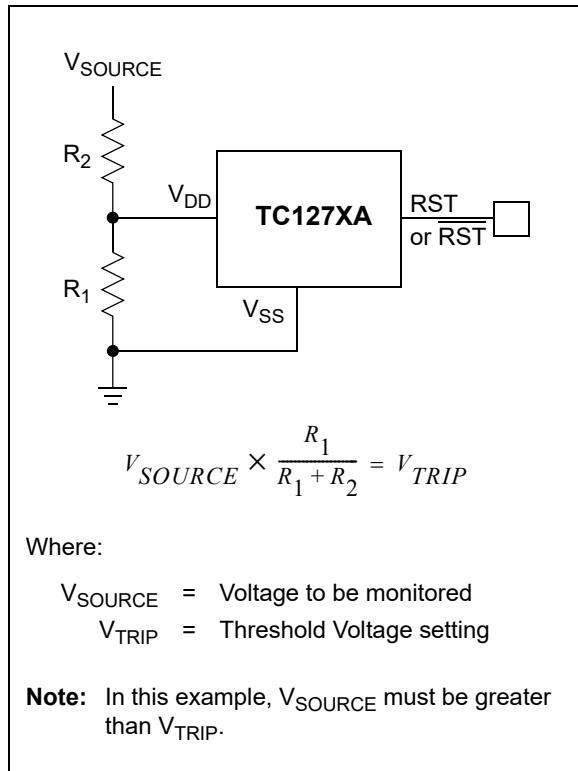

FIGURE 5-5: Modifying Trip-Point using External Resistor Divider.

5.5 MOSFET Low-Drive Protection

Low operating power and small physical size make the TC1270AN series ideal for many voltage detector applications. Figure 5-6 shows a low-voltage gate drive protection circuit that prevents the logic-level MOSFET from overheating due to insufficient gate voltage. When the input signal is below the threshold of the TC1270AN, its output grounds the gate of the MOSFET.

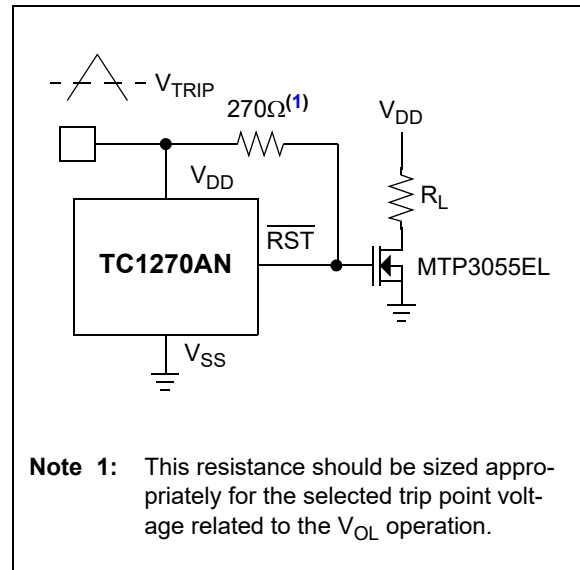

FIGURE 5-6: MOSFET Low-Drive Protection.

5.6 Controllers and Processors With Bidirectional I/O Pins

Some microcontrollers have bidirectional Reset pins. Depending on the current drive capability of the controller pin, an indeterminate logic level may result if there is a logic conflict. This can be avoided by adding a 4.7 kΩ resistor in series with the output of the TC127XA (Figure 5-7). If there are other components in the system that require a Reset signal, they should be buffered so as not to load the Reset line. If the other components are required to follow the Reset I/O of the microcontroller, the buffer should be connected as shown with the solid line.

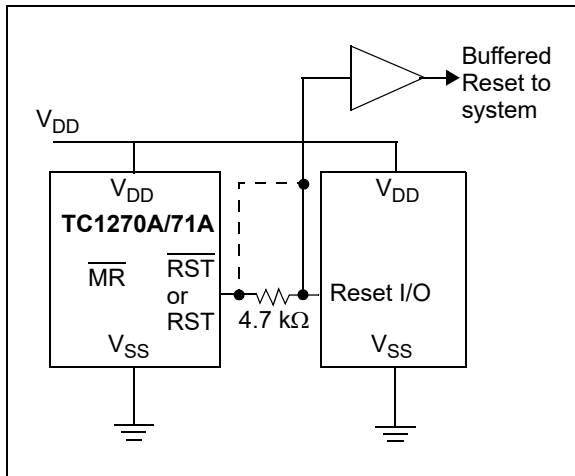

FIGURE 5-7: Interfacing the TC1270A or TC1271A Push-Pull Output to a Bidirectional Reset I/O pin.

5.7 Migration Paths

Figure 5-8 shows the 5-pin SOT-23 footprint of the TC1270A, TC1270AN and TC1271A devices. Devices that are in the 3-pin SOT-23 package could be used in that circuit with the loss of manual Reset functionality. Examples of compatible footprint devices in the SOT-23-3 package are the MCP111, MCP112, TC54 and TC51 devices. This allows the system to be designed to offer a “base” functionality and a higher end system with the “enhanced” functionality, which includes a manual Reset.

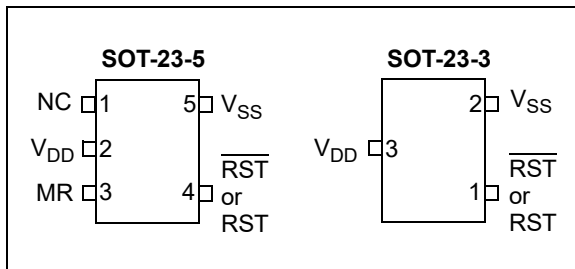

FIGURE 5-8: SOT-23 5-pin to 3-pin Comparison.

5.8 Reset Signal Integrity During Power-Down

The TC1270A and TC1271A Reset output is valid down to $V_{DD} = 1.0V$. Below this voltage the output becomes an “open circuit” and does not sink current. This means CMOS logic inputs to the microcontroller will be floating at an undetermined voltage. Most digital systems are completely shut down well above this voltage. However, in situations where the Reset signal must be maintained valid to $V_{DD} = 0V$, external circuitry is required.

For devices where the Reset signal is active-low, a pull-down resistor must be connected from the TC1270A RST pin to ground to discharge stray capacitances and hold the output low (Figure 5-9).

Similarly for devices where the Reset signal is active-high, a pull-up resistor to V_{DD} is required to ensure a valid high RST signal for V_{DD} below 1.0V (Figure 5-10).

This resistor value, though not critical, should be chosen such that it does not appreciably load the Reset pin under normal operation (100 kΩ should be suitable for most applications).

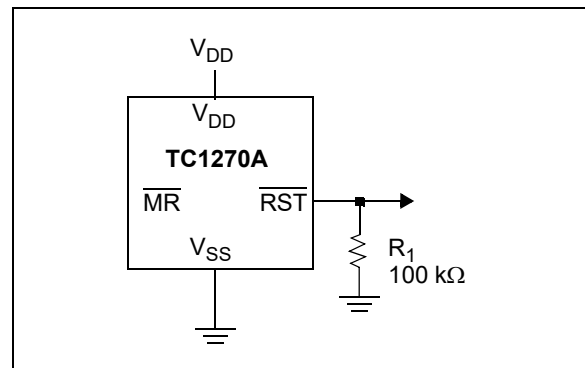

FIGURE 5-9: Ensuring a valid active-low Reset pin output state as V_{DD} approaches 0V.

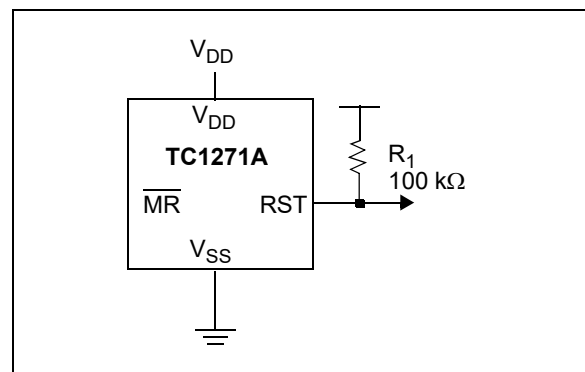

FIGURE 5-10: Ensuring a valid active-high Reset pin output state as V_{DD} approaches 0V.

TC1270A/70AN/71A

NOTES:

TC1270A/70AN/71A

6.0 STANDARD DEVICES

Configurations can include the following options:

Table 6-1 shows the standard devices, with order numbers, as well as the corresponding configurations.

- Voltage Trip Point (V_{TRIP})
- Reset Time Out (t_{RST})

TABLE 6-1: STANDARD VERSIONS

Device	Reset Threshold (V)				Reset Time Out (ms)				Package	Order Number	Replaces
	Minimum	Typical	Maximum	Code	Minimum	Typical	Maximum	Code ⁽¹⁾			
TC1270A	4.50	4.63	4.75	L	140	280	560	"blank"	SOT-23-5	TC1270ALVCTTR	—
									SOT-143	TC1270ALVRCTR	TC1270LERC/ TCM811LERC
TC1270A	4.25	4.38	4.50	M	140	280	560	"blank"	SOT-23-5	TC1270AMVCTTR	—
									SOT-143	TC1270AMVRCTR	TC1270MERC/ TCM811MERC
TC1270A	3.00	3.08	3.15	T	140	280	560	"blank"	SOT-23-5	TC1270ATVCTTR	—
									SOT-143	TC1270ATVRCTR	TC1270TERC/ TCM811TERC
TC1270A	2.85	2.93	3.00	S	140	280	560	"blank"	SOT-23-5	TC1270ASVCTTR	—
									SOT-143	TC1270ASVRCTR	TC1270SERC/ TCM811SERC
TC1270A	2.55	2.63	2.70	R	140	280	560	"blank"	SOT-23-5	TC1270ARVCTTR	—
									SOT-143	TC1270ARVRCTR	TC1270RERC/ TCM811RERC
TC1270AN	4.50	4.63	4.75	L	140	280	560	"blank"	SOT-23-5	TC1270ANLVCTTR	—
									SOT-143	TC1270ANLVRCTR	—
TC1270AN	4.25	4.38	4.50	M	140	280	560	"blank"	SOT-23-5	TC1270ANMVCTTR	—
									SOT-143	TC1270ANMVRCTR	—
TC1270AN	3.00	3.08	3.15	T	140	280	560	"blank"	SOT-23-5	TC1270ANTVCTTR	—
									SOT-143	TC1270ANTVRCTR	—
TC1270AN	2.85	2.93	3.00	S	140	280	560	"blank"	SOT-23-5	TC1270ANSVCTTR	—
									SOT-143	TC1270ANSVRCTR	—
TC1270AN	2.55	2.63	2.70	R	140	280	560	"blank"	SOT-23-5	TC1270ANRVCTTR	—
									SOT-143	TC1270ANRVRCTR	—
TC1271A	4.50	4.63	4.75	L	140	280	560	"blank"	SOT-23-5	TC1271ALVCTTR	—
									SOT-143	TC1271ALVRCTR	TC1271LERC/ TCM812LERC
TC1271A	4.25	4.38	4.50	M	140	280	560	"blank"	SOT-23-5	TC1271AMVCTTR	—
									SOT-143	TC1271AMVRCTR	TC1271MERC/ TCM812MERC
TC1271A	3.00	3.08	3.15	T	140	280	560	"blank"	SOT-23-5	TC1271ATVCTTR	—
									SOT-143	TC1271ATVRCTR	TC1271TERC/ TCM812TERC
TC1271A	2.85	2.93	3.00	S	140	280	560	"blank"	SOT-23-5	TC1271ASVCTTR	—
									SOT-143	TC1271ASVRCTR	TC1271SERC/ TCM812SERC
TC1271A	2.55	2.63	2.70	R	140	280	560	"blank"	SOT-23-5	TC1271ARVCTTR	—
									SOT-143	TC1271ARVRCTR	TC1271RERC/ TCM812RERC

Note 1: "A" time-out delay options are only standard in the SOT-23-5 package. SOT-143 package is a custom request.

TC1270A/70AN/71A

NOTES:

7.0 CUSTOM CONFIGURATIONS

The following Custom Reset Trip Point is available (see [Table 7-1](#)).

TABLE 7-1: CUSTOM TRIP POINT

Trip Voltage Selection	$V_{TRIP(MAX)}/V_{TRIP(MIN)}$	- % From Regulated Voltage
		3.0V
(1)	2.85V	5.0%
	2.70V	10.0%

Note 1: Contact your local Microchip sales office for additional information.

[Table 7-2](#) shows the codes that specify the desired Reset time out (t_{RST}) for custom devices.

TABLE 7-2: DELAY TIME OUT ORDERING CODES

Code	Reset Delay Time (Typ) (ms)	Comment
A	35	Note 1
B	2.19	Note 1
"blank"	280	Delay timings for standard device offerings

Note 1: This delay timing option is not the standard offering. For information on ordering devices with these delay times, contact your local Microchip sales office. Minimum purchase volumes are required.

TC1270A/70AN/71A

NOTES:

8.0 DEVELOPMENT TOOLS

8.1 Evaluation/Demonstration Boards

The SOT-23-5/6 Evaluation Board (VSUPEV2) can be used to evaluate the characteristics of the TC127XA devices.

This blank PCB has footprints for:

- Pull-up Resistor
- Pull-down Resistor
- Loading Capacitor
- In-line Resistor

There is also a power supply filtering capacitor.

For evaluating the TC127XA devices, the selected device should be installed into the Option A footprint.

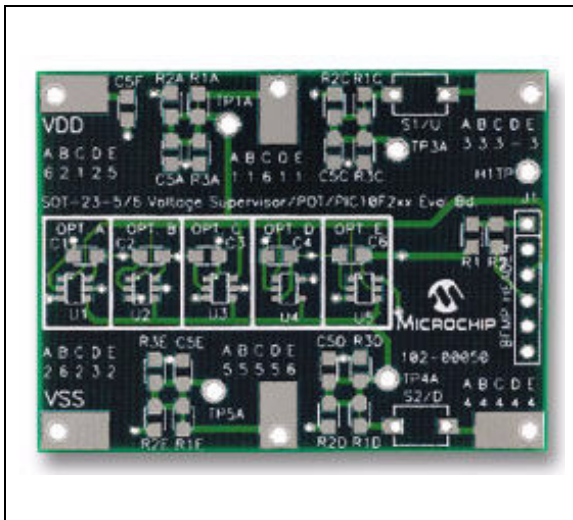

FIGURE 8-1: SOT-23-5/6 Voltage Supervisor Evaluation Board (VSUPEV2).

The SOIC-14 Evaluation Board (SOIC14EV) has a SOT-23-6 footprint that can be jumpered into any portion of the circuit. This will allow any footprint that the TC1270A requires in the SOT-23-5 package.

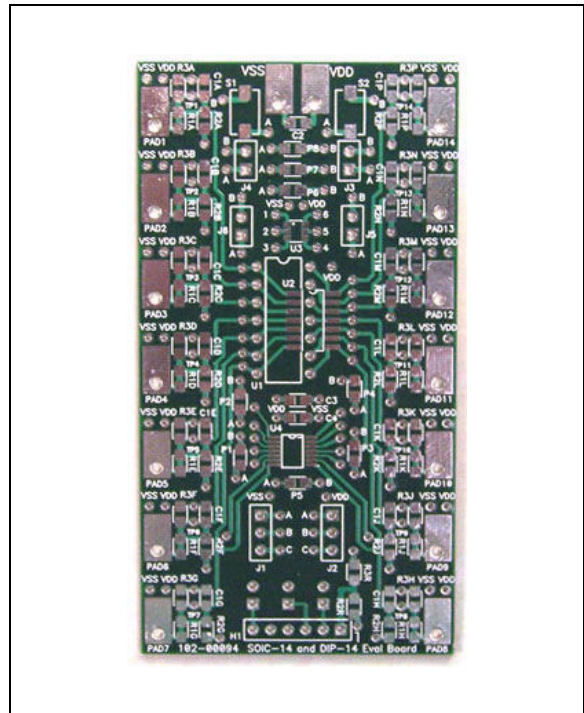

FIGURE 8-2: SOIC-14 Evaluation Board (Microchip Part Number SOIC14EV).

The PCB number, 102-00094, appears on the lower left side of the board. These evaluation boards can be purchased directly from the Microchip web site at www.microchip.com.

TC1270A/70AN/71A

NOTES:

9.0 PACKAGING INFORMATION

9.1 Package Marking Information

5-Pin SOT-23

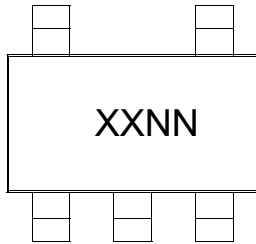

Part Number	Code	Part Number	Code
TC1270ALVCTTR	F1NN	TC1271ALVCTTR	J1NN
TC1270AMVCTTR	F2NN	TC1271AMVCTTR	J2NN
TC1270ATVCTTR	F3NN	TC1271ATVCTTR	J3NN
TC1270ASVCTTR	F4NN	TC1271ASVCTTR	J4NN
TC1270ARVCTTR	F5NN	TC1271ARVCTTR	J5NN
TC1270ANLVCTTR	FSNN	TC1270ATAVCTTR-V01	G7NN
TC1270ANMVCTTR	FTNN	TC1270ANMAVCTTR-V02	H8NN
TC1270ANTVCTTR	FUNN	TC1270ANSBVCTTR-V01	PLNN
TC1270ANSVCTTR	FVNN	TC1270AMBVCTTR-V02	LRNN
TC1270ANRVCTTR	FWNN	TC1270ASBVCTTRVAO	LPNN

Example:

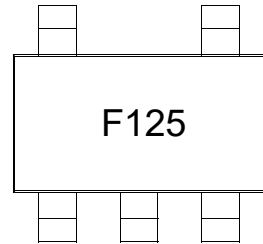

4-Lead SOT-143

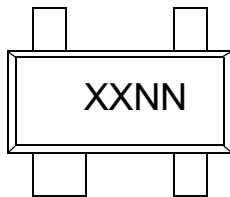

Part Number	Code	Part Number	Code
TC1270ALVRCTR	D1NN	TC1271ALVRCTR	C1NN
TC1270AMVRCTR	D2NN	TC1271AMVRCTR	C2NN
TC1270ATVRCTR	D3NN	TC1271ATVRCTR	C3NN
TC1270ASVRCTR	D4NN	TC1271ASVRCTR	C4NN
TC1270ARVRCTR	D5NN	TC1271ARVRCTR	C5NN
TC1270ANLVRCTR	E1NN	TC1270ARVRCTR-VAO	D5NN
TC1270ANMVRCTR	E2NN		
TC1270ANTVRCTR	E3NN		
TC1270ANSVRCTR	E4NN		
TC1270ANRVRCTR	E5NN		

Example:

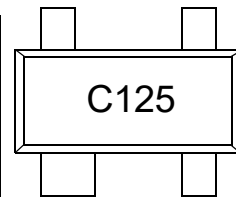

Legend: XX...X Customer-specific information
 Y Year code (last digit of calendar year)
 YY Year code (last 2 digits of calendar year)
 WW Week code (week of January 1 is week '01')
 NN Alphanumeric traceability code
 Ⓜ Pb-free JEDEC designator for Matte Tin (Sn)
 * This package is Pb-free. The Pb-free JEDEC designator Ⓜ can be found on the outer packaging for this package.

Note: In the event the full Microchip part number cannot be marked on one line, it will be carried over to the next line, thus limiting the number of available characters for customer-specific information.

TC1270A/70AN/71A

5-Lead Plastic Small Outline Transistor (CT) [SOT23]

Note: For the most current package drawings, please see the Microchip Packaging Specification located at <http://www.microchip.com/packaging>

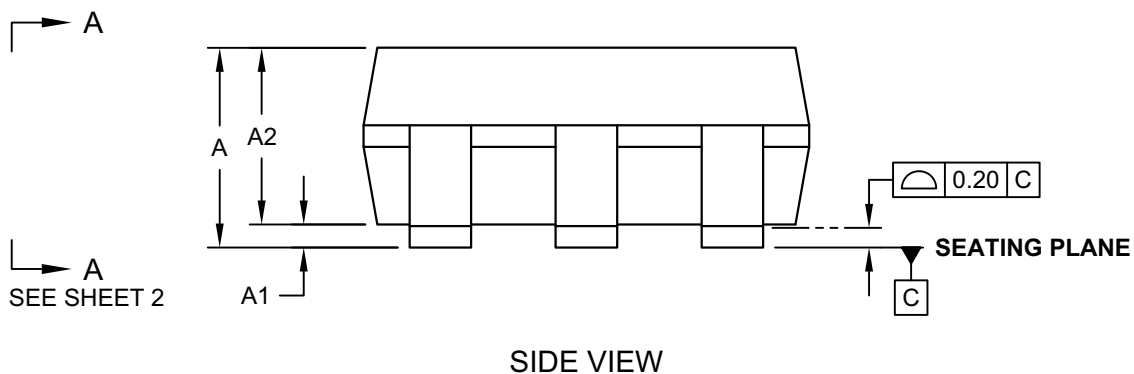
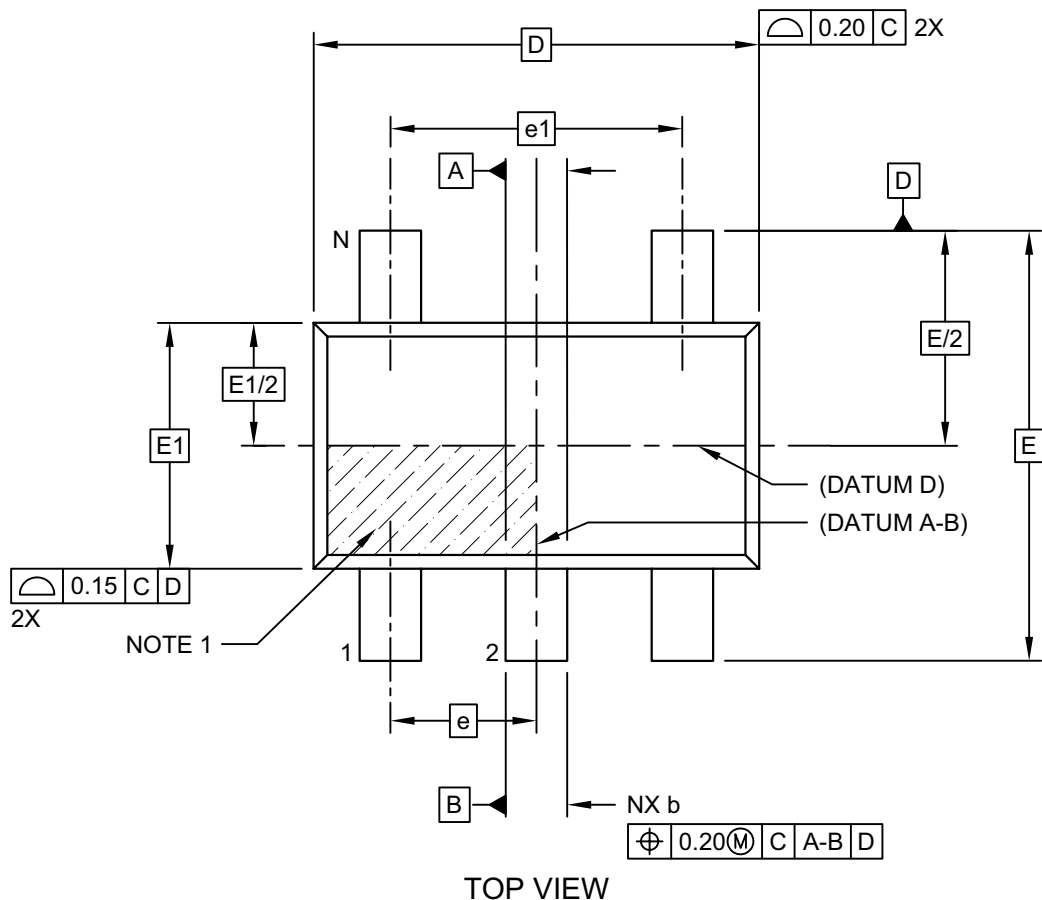

Microchip Technology Drawing C04-091-CT Rev F Sheet 1 of 2

TC1270A/70AN/71A

5-Lead Plastic Small Outline Transistor (CT) [SOT23]

Note: For the most current package drawings, please see the Microchip Packaging Specification located at <http://www.microchip.com/packaging>

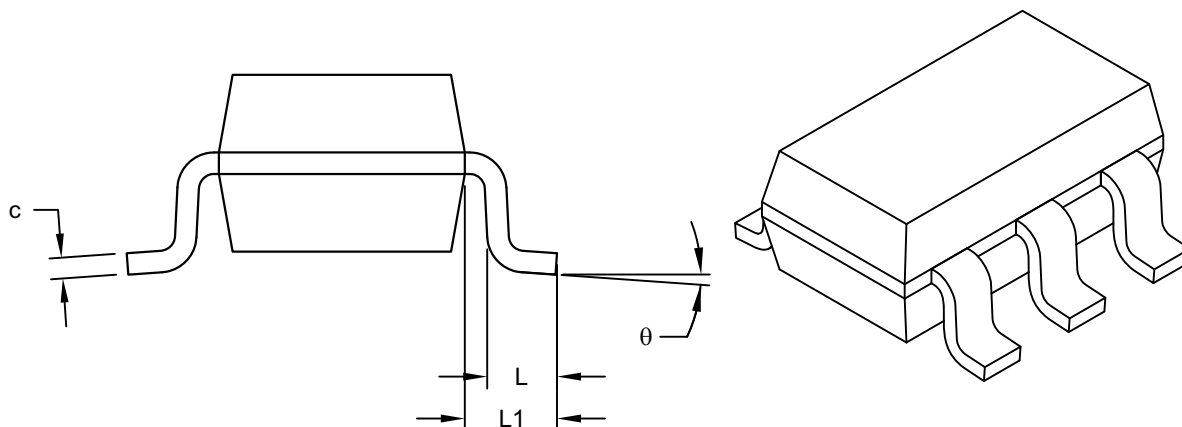

VIEW A-A
SHEET 1

Dimension Limits	Units	MILLIMETERS		
		MIN	NOM	MAX
Number of Pins	N	5		
Pitch	e	0.95 BSC		
Outside lead pitch	e1	1.90 BSC		
Overall Height	A	0.90	-	1.45
Molded Package Thickness	A2	0.89	-	1.30
Standoff	A1	-	-	0.15
Overall Width	E	2.80 BSC		
Molded Package Width	E1	1.60 BSC		
Overall Length	D	2.90 BSC		
Foot Length	L	0.30	-	0.60
Footprint	L1	0.60 REF		
Foot Angle	φ	0°	-	10°
Lead Thickness	c	0.08	-	0.26
Lead Width	b	0.20	-	0.51

Notes:

- Dimensions D and E1 do not include mold flash or protrusions. Mold flash or protrusions shall not exceed 0.25mm per side.
- Dimensioning and tolerancing per ASME Y14.5M
BSC: Basic Dimension. Theoretically exact value shown without tolerances.
REF: Reference Dimension, usually without tolerance, for information purposes only.

Microchip Technology Drawing C04-091-CT Rev F Sheet 2 of 2

TC1270A/70AN/71A

5-Lead Plastic Small Outline Transistor (CT) [SOT23]

Note: For the most current package drawings, please see the Microchip Packaging Specification located at <http://www.microchip.com/packaging>

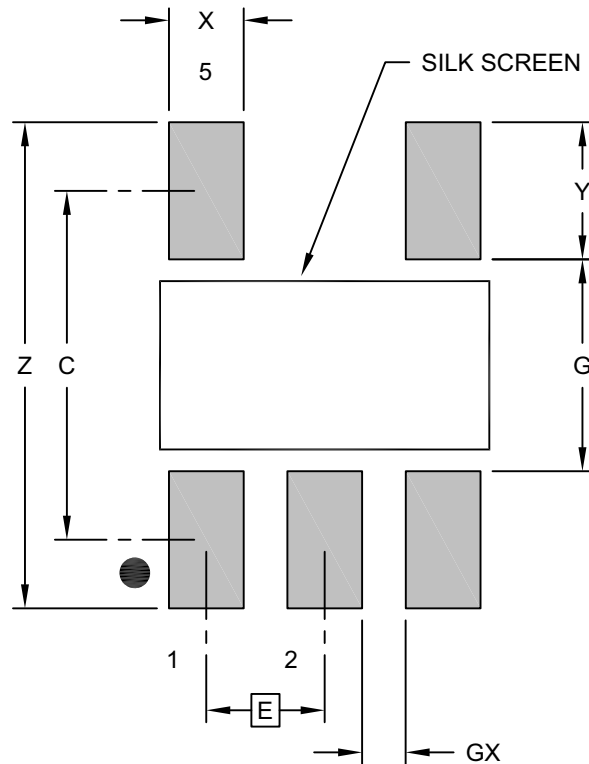

RECOMMENDED LAND PATTERN

Dimension Limits	Units	MILLIMETERS		
		MIN	NOM	MAX
Contact Pitch	E	0.95 BSC		
Contact Pad Spacing	C		2.80	
Contact Pad Width (X5)	X			0.60
Contact Pad Length (X5)	Y			1.10
Distance Between Pads	G	1.70		
Distance Between Pads	GX	0.35		
Overall Width	Z			3.90

Notes:

1. Dimensioning and tolerancing per ASME Y14.5M

BSC: Basic Dimension. Theoretically exact value shown without tolerances.

Microchip Technology Drawing No. C04-2091-CT Rev F

TC1270A/70AN/71A

4-Lead Plastic Small Outline Transistor (RC) [SOT-143]

Note: For the most current package drawings, please see the Microchip Packaging Specification located at <http://www.microchip.com/packaging>

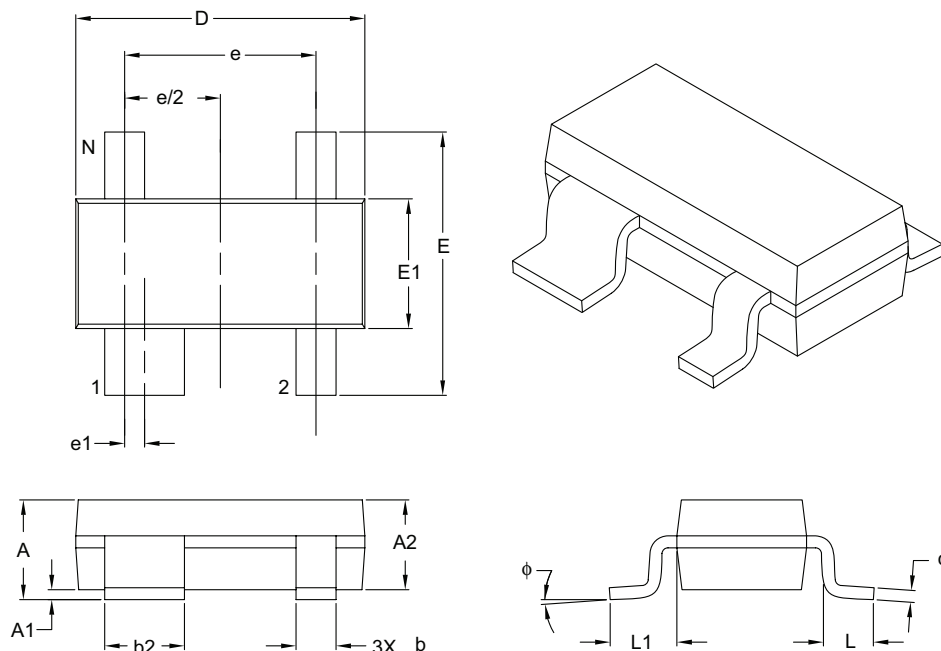

Dimension Limits	Units	MILLIMETERS		
		MIN	NOM	MAX
Number of Pins	N	4		
Pitch	e	1.92 BSC		
Lead 1 Offset	e1	0.20 BSC		
Overall Height	A	0.80	–	1.22
Molded Package Thickness	A2	0.75	0.90	1.07
Standoff §	A1	0.01	–	0.15
Overall Width	E	2.10	–	2.64
Molded Package Width	E1	1.20	1.30	1.40
Overall Length	D	2.67	2.90	3.05
Foot Length	L	0.13	0.50	0.60
Footprint	L1	0.54 REF		
Foot Angle	ϕ	0°	–	8°
Lead Thickness	c	0.08	–	0.20
Lead 1 Width	b1	0.76	–	0.94
Leads 2, 3 & 4 Width	b	0.30	–	0.54

Notes:

- § Significant Characteristic.
- Dimensions D and E1 do not include mold flash or protrusions. Mold flash or protrusions shall not exceed 0.25 mm per side.
- Dimensioning and tolerancing per ASME Y14.5M.

BSC: Basic Dimension. Theoretically exact value shown without tolerances.

REF: Reference Dimension, usually without tolerance, for information purposes only.

Microchip Technology Drawing C04-031B

TC1270A/70AN/71A

4-Lead Plastic Small Outline Transistor (RC) [SOT-143]

Note: For the most current package drawings, please see the Microchip Packaging Specification located at <http://www.microchip.com/packaging>

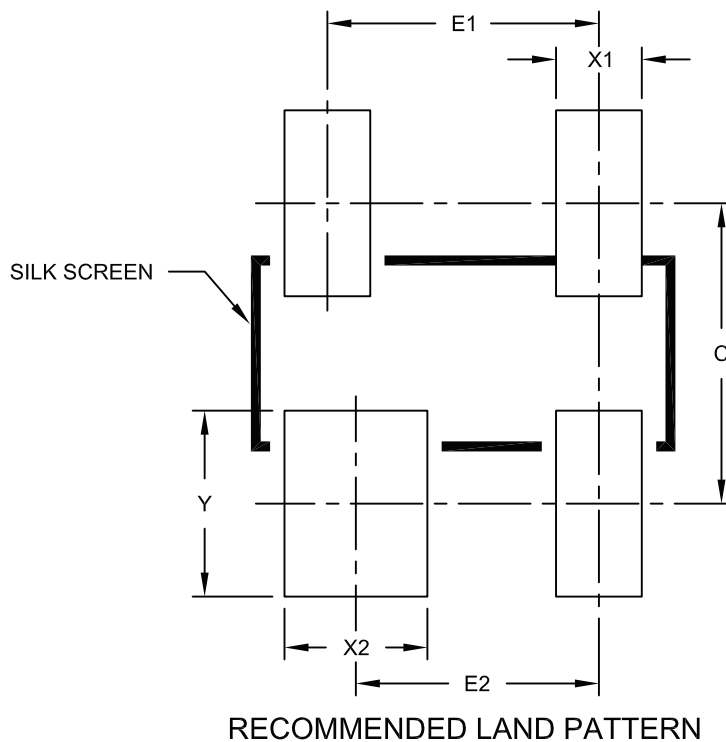

Dimension Limits	Units	MILLIMETERS		
		MIN	NOM	MAX
Contact Pitch	E1	1.90 BSC		
Contact Pitch	E2	1.60 BSC		
Contact Width	X1			0.60
Contact Width	X2			1.00
Contact Length	Y			1.30
Contact Pad Spacing	C		2.10	

Notes:

1. Dimensioning and tolerancing per ASME Y14.5M

BSC: Basic Dimension. Theoretically exact value shown without tolerances.

Microchip Technology Drawing No. C04-2031A

9.2 Product Tape and Reel Specifications

FIGURE 9-1: EMBOSSED CARRIER DIMENSIONS (8 MM TAPE ONLY)

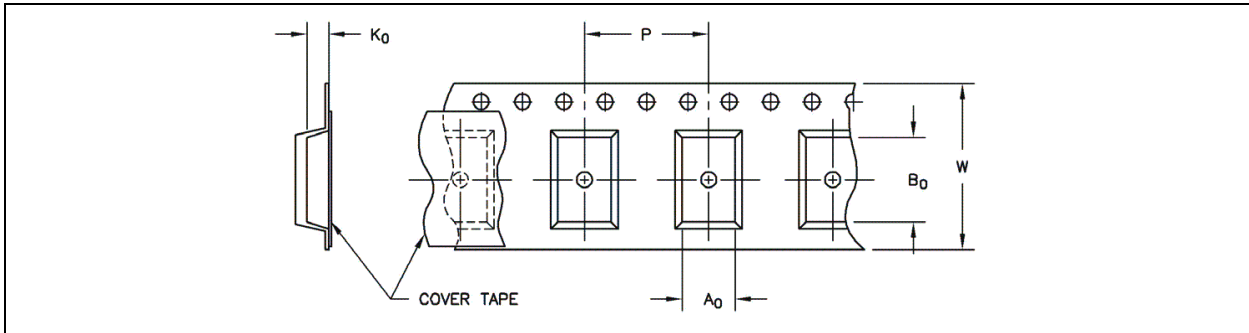
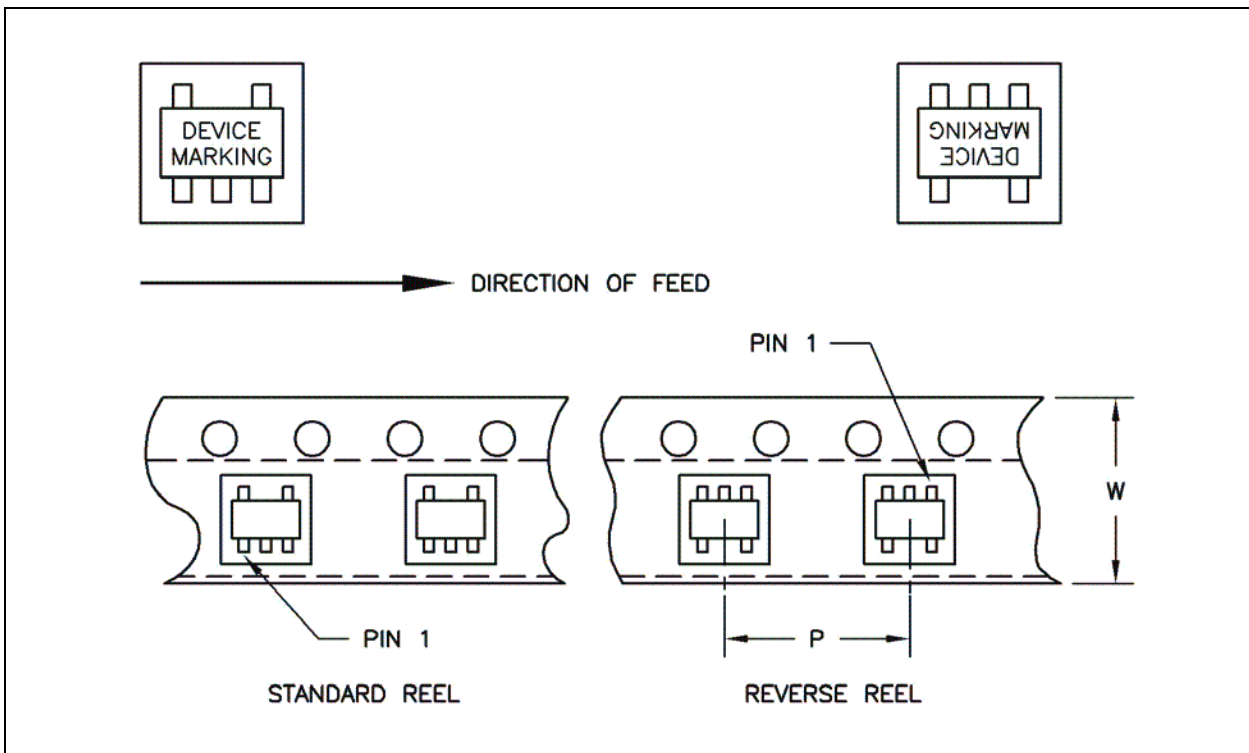

TABLE 1: CARRIER TAPE/CAVITY DIMENSIONS

Case Outline	Package Type		Carrier Dimensions		Cavity Dimensions			Output Quantity Units	Reel Diameter in mm
			W mm	P mm	A0 mm	B0 mm	K0 mm		
CT	SOT-23	5L	8	4	3.23	3.17	1.37	3000	180
RC	SOT-143	4L	8	4	3.1	2.69	1.3	3000	330

FIGURE 9-2: 5-LEAD SOT-23 DEVICE TAPE AND REEL SPECIFICATIONS



TC1270A/70AN/71A

FIGURE 9-3: 4-LEAD SOT-143 DEVICE TAPE AND REEL SPECIFICATIONS

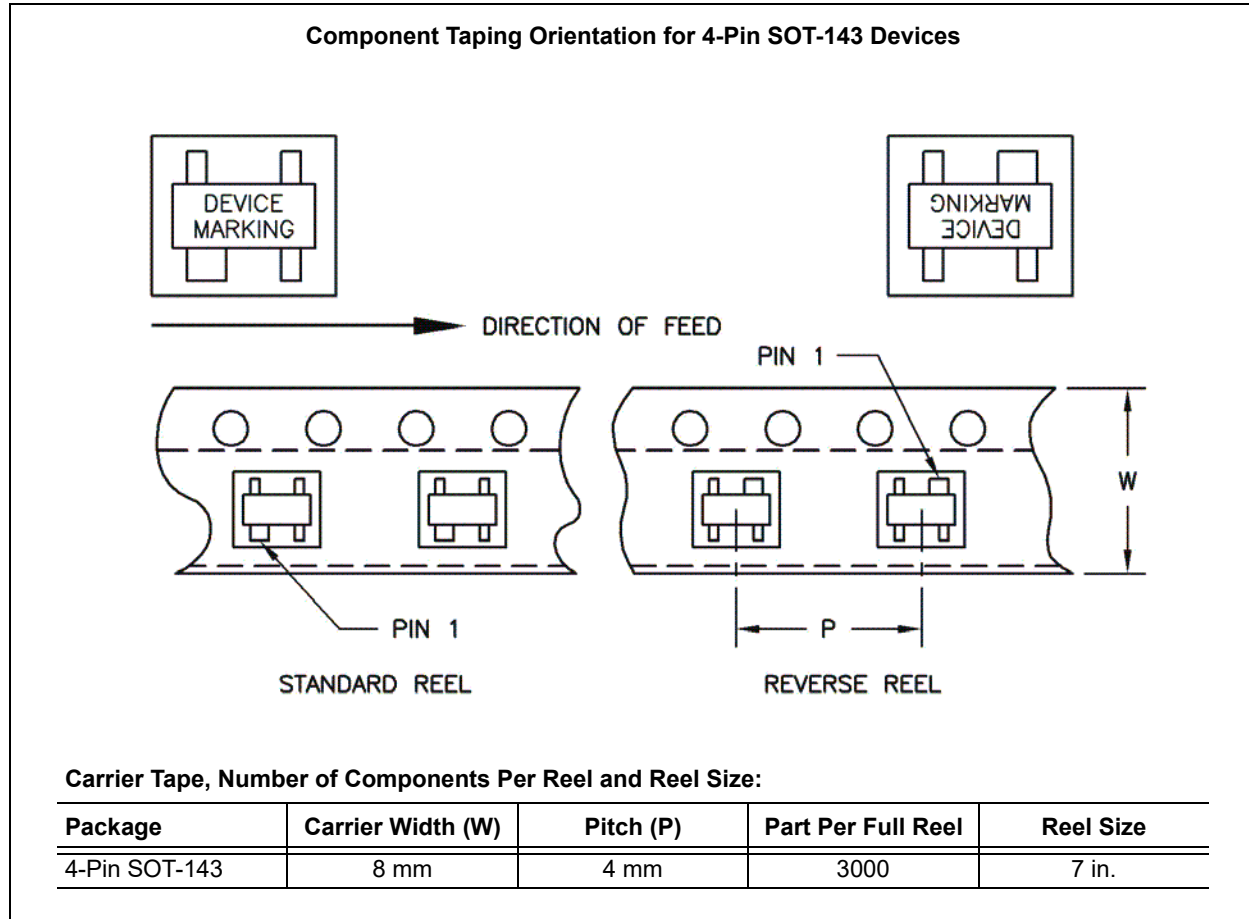

APPENDIX A: REVISION HISTORY

Revision E (May 2021)

The following is the list of modifications:

- Updated the [Features](#) section.
- Updated the [Temperature Characteristics](#) table.
- Updated [Section 9.0 “Packaging information”](#) with Automotive examples and current Package Drawings.
- Updated the [Product Identification System](#) to include Automotive examples.
- Minor editorial corrections.

Revision D (August 2011)

The following is the list of modifications:

- Added the SOT-143 package to the TC1270AN device and related information throughout the document.

Revision C (October 2010)

The following is the list of modifications:

- Modified the [Product Identification System](#) section to reflect the custom manufacturing code used for devices with a Reset Delay time out of 35 ms (was a “C”, now is an “A”).
- Clarified information presented in [Section 4.2 “Voltage Detect Circuit”](#).

Revision B (June 2007)

The following is the list of modifications:

- Added new options:
 - Open-Drain output
 - New Reset Delay time outs.
- Updated Package Outline Drawings.
- Added new options to the [Product Identification System](#) section.

Revision A (March 2007)

- Original Release of this Document.

NOTES:

TC1270A/70AN/71A

PRODUCT IDENTIFICATION SYSTEM

To order or obtain information, e.g., on pricing or delivery, refer to the factory or the listed sales office.

PART NO.	XX	X	X	XX	X
Device	V _{TRIP} Options	Reset Delay Options	Temperature Range	Package	Tape/Reel Option
Device: TC1270A: Voltage Supervisor with Manual Reset TC1270AN: Voltage Supervisor with Manual Reset TC1271A: Voltage Supervisor with Manual Reset					
V_{TRIP} Options: R = 2.55V (min.) / 2.63V (typ.) / 2.70V (max.) S = 2.85V (min.) / 2.93V (typ.) / 3.00V (max.) T = 3.00V (min.) / 3.08V (typ.) / 3.15V (max.) M = 4.25V (min.) / 4.38V (typ.) / 4.50V (max.) L = 4.50V (min.) / 4.63V (typ.) / 4.75V (max.)					
Time-Out Options: "blank" = t _{RST} = 280 ms (typ) A = t _{RST} = 35 ms (typ) B = t _{RST} = 2.19 ms (typ)					
Temperature Range: V = -40°C to +125°C					
Package: CT = Plastic Small Outline Transistor, SOT-23, 5-lead RC = Plastic Small Outline Transistor, SOT-143, 4-lead					
Tape/Reel Option: TR = Tape and Reel					
Automotive Option VAO V01 V02					
Examples: a) TC1270ASVCTTR: 2.85V min./2.93V typ./3.00V max. voltage trip point, Push-pull active-low Reset, Reset Delay Timer = 280 ms, 5-LD SOT-23, Tape and Reel, -40°C to +125°C b) TC1270ALVRCR: 4.50V min./4.63V typ./4.75V max. voltage trip point, Push-pull active-low Reset, Reset Delay Timer = 280 ms, 4-LD SOT-143, Tape and Reel, -40°C to +125°C c) TC1270ANMBVCTTR: 4.25V min./4.38V typ./4.50V max. Open-drain active-low Reset, Reset Delay Timer = 2.19 ms, 5-Lead SOT-23, Tape and Reel, -40°C to +125°C d) TC1270ANLAVCT: 4.50V min./4.63V typ./4.75V max. Open-drain active-low Reset, Reset Delay Timer = 35 ms, 5-Lead SOT-23, -40°C to +125°C e) TC1271ARVCTTR: 2.55V min./2.63V typ./2.70V max. voltage trip point, Push-pull active-high Reset, Reset Delay Timer = 280 ms, 5-LD SOT-23, Tape and Reel, -40°C to +125°C f) TC1271ATVRCR: 3.00V min./3.08V typ./3.15V max. voltage trip point, Push-pull active-high Reset, Reset Delay Timer = 280 ms, 4-LD SOT-143, Tape and Reel, -40°C to +125°C g) TC1270ARVRCR-VAO: 2.55V min./2.63V typ./2.70V max. voltage trip point, Push-pull active-high Reset, Reset Delay Timer = 280 ms, 4-LD SOT-143, Tape and Reel, -40°C to +125°C, Automotive h) TC1270ATAVCTTR-V01: 3.00V min./3.08V typ./3.15V max. voltage trip point, Push-pull active-high Reset, Reset Delay Timer = 35 ms, 5-LD SOT-23, Tape and Reel, -40°C to +125°C, Automotive i) TC1270ANMAVCTTR-V02: 4.25V min./4.38V typ./4.50V max. voltage trip point, Push-pull active-high Reset, Reset Delay Timer = 35 ms, 5-LD SOT-23, Tape and Reel, -40°C to +125°C, Automotive j) TC1270ASBVCTTRVAO: 2.85V min./2.93V typ./3.00V max. voltage trip point, Push-pull active-high Reset, Reset Delay Timer = 2.19 ms, 5-LD SOT-23, Tape and Reel, -40°C to +125°C, Automotive k) TC1270AMBVCTTR-VAO: 4.25V min./4.38V typ./4.50V max. voltage trip point, Push-pull active-high Reset, Reset Delay Timer = 2.19 ms, 5-LD SOT-23, Tape and Reel, -40°C to +125°C, Automotive					

TC1270A/70AN/71A

NOTES:

Note the following details of the code protection feature on Microchip devices:

- Microchip products meet the specifications contained in their particular Microchip Data Sheet.
- Microchip believes that its family of products is secure when used in the intended manner and under normal conditions.
- There are dishonest and possibly illegal methods being used in attempts to breach the code protection features of the Microchip devices. We believe that these methods require using the Microchip products in a manner outside the operating specifications contained in Microchip's Data Sheets. Attempts to breach these code protection features, most likely, cannot be accomplished without violating Microchip's intellectual property rights.
- Microchip is willing to work with any customer who is concerned about the integrity of its code.
- Neither Microchip nor any other semiconductor manufacturer can guarantee the security of its code. Code protection does not mean that we are guaranteeing the product is "unbreakable." Code protection is constantly evolving. We at Microchip are committed to continuously improving the code protection features of our products. Attempts to break Microchip's code protection feature may be a violation of the Digital Millennium Copyright Act. If such acts allow unauthorized access to your software or other copyrighted work, you may have a right to sue for relief under that Act.

Information contained in this publication is provided for the sole purpose of designing with and using Microchip products. Information regarding device applications and the like is provided only for your convenience and may be superseded by updates. It is your responsibility to ensure that your application meets with your specifications.

THIS INFORMATION IS PROVIDED BY MICROCHIP "AS IS". MICROCHIP MAKES NO REPRESENTATIONS OR WARRANTIES OF ANY KIND WHETHER EXPRESS OR IMPLIED, WRITTEN OR ORAL, STATUTORY OR OTHERWISE, RELATED TO THE INFORMATION INCLUDING BUT NOT LIMITED TO ANY IMPLIED WARRANTIES OF NON-INFRINGEMENT, MERCHANTABILITY, AND FITNESS FOR A PARTICULAR PURPOSE OR WARRANTIES RELATED TO ITS CONDITION, QUALITY, OR PERFORMANCE.

IN NO EVENT WILL MICROCHIP BE LIABLE FOR ANY INDIRECT, SPECIAL, PUNITIVE, INCIDENTAL OR CONSEQUENTIAL LOSS, DAMAGE, COST OR EXPENSE OF ANY KIND WHATSOEVER RELATED TO THE INFORMATION OR ITS USE, HOWEVER CAUSED, EVEN IF MICROCHIP HAS BEEN ADVISED OF THE POSSIBILITY OR THE DAMAGES ARE FORESEEABLE. TO THE FULLEST EXTENT ALLOWED BY LAW, MICROCHIP'S TOTAL LIABILITY ON ALL CLAIMS IN ANY WAY RELATED TO THE INFORMATION OR ITS USE WILL NOT EXCEED THE AMOUNT OF FEES, IF ANY, THAT YOU HAVE PAID DIRECTLY TO MICROCHIP FOR THE INFORMATION. Use of Microchip devices in life support and/or safety applications is entirely at the buyer's risk, and the buyer agrees to defend, indemnify and hold harmless Microchip from any and all damages, claims, suits, or expenses resulting from such use. No licenses are conveyed, implicitly or otherwise, under any Microchip intellectual property rights unless otherwise stated.

Trademarks

The Microchip name and logo, the Microchip logo, Adaptec, AnyRate, AVR, AVR logo, AVR Freaks, BesTime, BitCloud, chipKIT, chipKIT logo, CryptoMemory, CryptoRF, dsPIC, FlashFlex, flexPWR, HELDO, IGL00, JukeBlox, KeeLoq, Kleer, LANCheck, LinkMD, maXStylus, maXTouch, MediaLB, megaAVR, Microsemi, Microsemi logo, MOST, MOST logo, MPLAB, OptoLyzer, PackeTime, PIC, picoPower, PICSTART, PIC32 logo, PolarFire, Prochip Designer, QTouch, SAM-BA, SenGenuity, SpyNIC, SST, SST Logo, SuperFlash, Symmetricom, SyncServer, Tachyon, TimeSource, tinyAVR, UNI/O, Vectron, and XMEGA are registered trademarks of Microchip Technology Incorporated in the U.S.A. and other countries.

AgileSwitch, APT, ClockWorks, The Embedded Control Solutions Company, EtherSynch, FlashTec, Hyper Speed Control, HyperLight Load, IntelliMOS, Libero, motorBench, mTouch, Powermite 3, Precision Edge, ProASIC, ProASIC Plus, ProASIC Plus logo, Quiet-Wire, SmartFusion, SyncWorld, Temux, TimeCesium, TimeHub, TimePictra, TimeProvider, WinPath, and ZL are registered trademarks of Microchip Technology Incorporated in the U.S.A.

Adjacent Key Suppression, AKS, Analog-for-the-Digital Age, Any Capacitor, AnyIn, AnyOut, Augmented Switching, BlueSky, BodyCom, CodeGuard, CryptoAuthentication, CryptoAutomotive, CryptoCompanion, CryptoController, dsPICDEM, dsPICDEM.net, Dynamic Average Matching, DAM, ECAN, Espresso T1S, EtherGREEN, IdealBridge, In-Circuit Serial Programming, ICSP, INICnet, Intelligent Paralleling, Inter-Chip Connectivity, JitterBlocker, maxCrypto, maxView, memBrain, Mindi, MiWi, MPASM, MPF, MPLAB Certified logo, MPLIB, MPLINK, MultiTRAK, NetDetach, Omniscient Code Generation, PICDEM, PICDEM.net, PICkit, PICtail, PowerSmart, PureSilicon, QMatrix, REAL ICE, Ripple Blocker, RTAX, RTG4, SAM-ICE, Serial Quad I/O, simpleMAP, SimpliPHY, SmartBuffer, SMART-I.S., storClad, SQI, SuperSwitcher, SuperSwitcher II, Switchtec, SynchroPHY, Total Endurance, TSHARC, USBCheck, VariSense, VectorBlox, VeriPHY, ViewSpan, WiperLock, XpressConnect, and ZENA are trademarks of Microchip Technology Incorporated in the U.S.A. and other countries.

SQTP is a service mark of Microchip Technology Incorporated in the U.S.A.

The Adaptec logo, Frequency on Demand, Silicon Storage Technology, and Symmcom are registered trademarks of Microchip Technology Inc. in other countries.

GestIC is a registered trademark of Microchip Technology Germany II GmbH & Co. KG, a subsidiary of Microchip Technology Inc., in other countries.

All other trademarks mentioned herein are property of their respective companies.

© 2007-2021, Microchip Technology Incorporated, All Rights Reserved.

ISBN: 978-1-5224-8200-0

For information regarding Microchip's Quality Management Systems, please visit www.microchip.com/quality.



MICROCHIP

Worldwide Sales and Service

AMERICAS

Corporate Office
2355 West Chandler Blvd.
Chandler, AZ 85224-6199
Tel: 480-792-7200
Fax: 480-792-7277
Technical Support:
<http://www.microchip.com/support>
Web Address:
www.microchip.com

Atlanta

Duluth, GA
Tel: 678-957-9614
Fax: 678-957-1455

Austin, TX

Tel: 512-257-3370

Boston

Westborough, MA
Tel: 774-760-0087
Fax: 774-760-0088

Chicago

Itasca, IL
Tel: 630-285-0071
Fax: 630-285-0075

Dallas

Addison, TX
Tel: 972-818-7423
Fax: 972-818-2924

Detroit

Novi, MI
Tel: 248-848-4000

Houston, TX

Tel: 281-894-5983

Indianapolis

Noblesville, IN
Tel: 317-773-8323
Fax: 317-773-5453
Tel: 317-536-2380

Los Angeles

Mission Viejo, CA
Tel: 949-462-9523
Fax: 949-462-9608
Tel: 951-273-7800

Raleigh, NC

Tel: 919-844-7510

New York, NY

Tel: 631-435-6000

San Jose, CA

Tel: 408-735-9110
Tel: 408-436-4270

Canada - Toronto

Tel: 905-695-1980
Fax: 905-695-2078

ASIA/PACIFIC

Australia - Sydney
Tel: 61-2-9868-6733

China - Beijing
Tel: 86-10-8569-7000

China - Chengdu
Tel: 86-28-8665-5511

China - Chongqing
Tel: 86-23-8980-9588

China - Dongguan
Tel: 86-769-8702-9880

China - Guangzhou
Tel: 86-20-8755-8029

China - Hangzhou
Tel: 86-571-8792-8115

China - Hong Kong SAR
Tel: 852-2943-5100

China - Nanjing
Tel: 86-25-8473-2460

China - Qingdao
Tel: 86-532-8502-7355

China - Shanghai
Tel: 86-21-3326-8000

China - Shenyang
Tel: 86-24-2334-2829

China - Shenzhen
Tel: 86-755-8864-2200

China - Suzhou
Tel: 86-186-6233-1526

China - Wuhan
Tel: 86-27-5980-5300

China - Xian
Tel: 86-29-8833-7252

China - Xiamen
Tel: 86-592-2388138

China - Zhuhai
Tel: 86-756-3210040

ASIA/PACIFIC

India - Bangalore
Tel: 91-80-3090-4444

India - New Delhi
Tel: 91-11-4160-8631

India - Pune
Tel: 91-20-4121-0141

Japan - Osaka
Tel: 81-6-6152-7160

Japan - Tokyo
Tel: 81-3-6880-3770

Korea - Daegu
Tel: 82-53-744-4301

Korea - Seoul
Tel: 82-2-554-7200

Malaysia - Kuala Lumpur
Tel: 60-3-7651-7906

Malaysia - Penang
Tel: 60-4-227-8870

Philippines - Manila
Tel: 63-2-634-9065

Singapore
Tel: 65-6334-8870

Taiwan - Hsin Chu
Tel: 886-3-577-8366

Taiwan - Kaohsiung
Tel: 886-7-213-7830

Taiwan - Taipei
Tel: 886-2-2508-8600

Thailand - Bangkok
Tel: 66-2-694-1351

Vietnam - Ho Chi Minh
Tel: 84-28-5448-2100

EUROPE

Austria - Wels
Tel: 43-7242-2244-39
Fax: 43-7242-2244-393

Denmark - Copenhagen
Tel: 45-4485-5910
Fax: 45-4485-2829

Finland - Espoo
Tel: 358-9-4520-820

France - Paris
Tel: 33-1-69-53-63-20
Fax: 33-1-69-30-90-79

Germany - Garching
Tel: 49-8931-9700

Germany - Haan
Tel: 49-2129-3766400

Germany - Heilbronn
Tel: 49-7131-72400

Germany - Karlsruhe
Tel: 49-721-625370

Germany - Munich
Tel: 49-89-627-144-0
Fax: 49-89-627-144-44

Germany - Rosenheim
Tel: 49-8031-354-560

Israel - Ra'anana
Tel: 972-9-744-7705

Italy - Milan
Tel: 39-0331-742611
Fax: 39-0331-466781

Italy - Padova
Tel: 39-049-7625286

Netherlands - Drunen
Tel: 31-416-690399
Fax: 31-416-690340

Norway - Trondheim
Tel: 47-7288-4388

Poland - Warsaw
Tel: 48-22-3325737

Romania - Bucharest
Tel: 40-21-407-87-50

Spain - Madrid
Tel: 34-91-708-08-90
Fax: 34-91-708-08-91

Sweden - Gothenberg
Tel: 46-31-704-60-40

Sweden - Stockholm
Tel: 46-8-5090-4654

UK - Wokingham
Tel: 44-118-921-5800
Fax: 44-118-921-5820