

ADA4945-1CP-EBZ Differential Amplifier Evaluation Board

FEATURES

Enables quick breadboarding and prototyping
User defined circuit configuration

GENERAL DESCRIPTION

The Analog Devices, Inc., ADA4945-1CP-EBZ evaluation board allows the user to evaluate the performance of the [ADA4945-1](#) fully differential amplifier. The ADA4945-1CP-EBZ evaluation board can be configured to accept either a single-ended or differential input signal.

The ADA4945-1CP-EBZ evaluation board uses several 2-pin and 3-pin headers to control various features of the [ADA4945-1](#). Apply the proper jumpers to set the [ADA4945-1](#) high and low output clamp levels, set the [ADA4945-1](#) output common-mode voltage, choose high or low power mode for the [ADA4945-1](#), and set the [ADA4945-1](#) digital ground level.

Optimized power and ground planes ensure low noise and high speed operation. Component placement and power supply bypassing provide maximum circuit flexibility and performance. The ADA4945-1CP-EBZ evaluation board accepts 0402 surface mount technology (SMT) components, 0805 bypass capacitors, and 2.54 mm headers.

Input and output signals are brought to and from the board via 50 Ω, side launch Subminiature Version A (SMA) connectors.

Full specifications on the [ADA4945-1](#) are available in the [ADA4945-1](#) data sheet. Consult the data sheet in conjunction with this user guide when working with the ADA4945-1CP-EBZ evaluation board.

EVALUATION BOARD PHOTOGRAPH



Figure 1.

16885-001

TABLE OF CONTENTS

Features	1	Setting the Digital Ground (DGND) Level	3
General Description	1	Output Common-Mode Voltage	3
Evaluation Board Photograph.....	1	Evaluation Board Schematic and Artwork.....	4
Revision History	2	Ordering Information.....	5
Functionality and Control.....	3	Bill of Materials.....	5
Output Clamps.....	3		

REVISION HISTORY

8/2020—Rev. 0 to Rev. A	
Changes to Figure 2.....	4

3/2019—Revision 0: Initial Version

FUNCTIONALITY AND CONTROL

OUTPUT CLAMPS

Use the 3-pin P4 and P5 headers to set the [ADA4945-1](#) output clamp voltage levels at the $+V_{CLAMP}$ pin and the $-V_{CLAMP}$ pin (see Figure 2 and Figure 3). To set the $+V_{CLAMP}$ voltage level to the positive supply (VCC), place a jumper across Pin 1 and Pin 2 of the P5 header. To set the $+V_{CLAMP}$ voltage level to any user defined level, apply an external voltage at Pin 2 of the P5 header. Pin 3 is connected to analog ground (AGND). Use the P4 header to set the $-V_{CLAMP}$ voltage level to the negative supply (VEE) or a user defined level.

SETTING THE DIGITAL GROUND (DGND) LEVEL

Use the 3-pin P2 header to set the logic reference (DGND) level to VEE, AGND, or a user defined level. To set the DGND level to VEE, place a jumper across Pin 1 and Pin 2 of the P2 header. To set the DGND level to AGND, place a jumper across Pin 2 and Pin 3 of the P2 header. If a different logic reference level is required, apply the desired voltage directly to Pin 2.

SUPPLIES, POWER MODES, AND DISABLE

The VCC and VEE power supplies are connected at the 3-pin P1 header.

Use the 3-pin P3 header to select full power operating mode or low power operating mode. Short Pin 1 and Pin 2 to place the [ADA4945-1](#) in full power operating mode. Short Pin 2 and Pin 3 to place the [ADA4945-1](#) in low power operating mode.

Short across the 2-pin PD header to place the [ADA4945-1](#) in disable mode.

OUTPUT COMMON-MODE VOLTAGE

To set the output common-mode voltage (V_{OCM}) to a user defined level, apply the desired voltage to the loop style VOXM test point. When no voltage is applied to the VOXM test point, the [ADA4945-1](#) V_{OCM} defaults to an internally generated level midway between $+V_{CLAMP}$ and $-V_{CLAMP}$.

EVALUATION BOARD SCHEMATIC AND ARTWORK

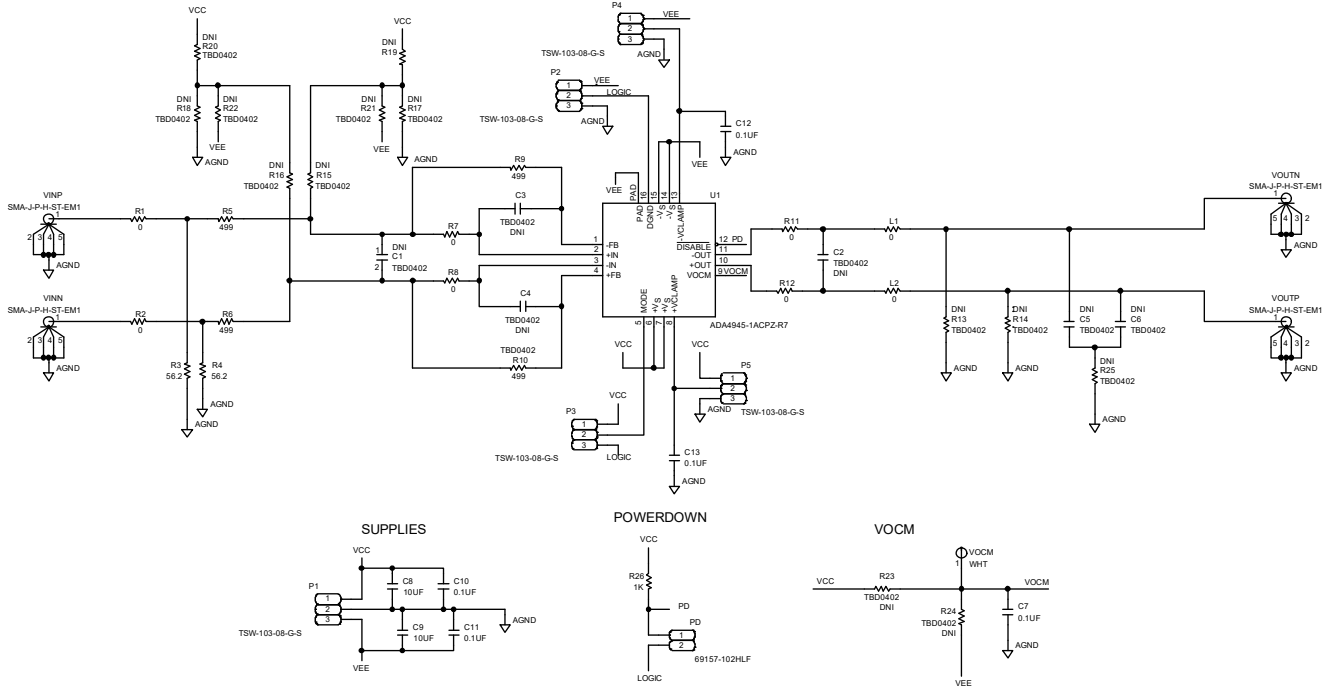

Figure 2. ADA4945-1CP-EBZ Evaluation Board Schematic

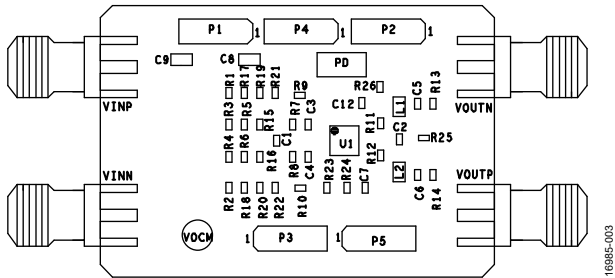

Figure 3. ADA4945-1CP-EBZ Evaluation Board Assembly Drawing, Primary Side

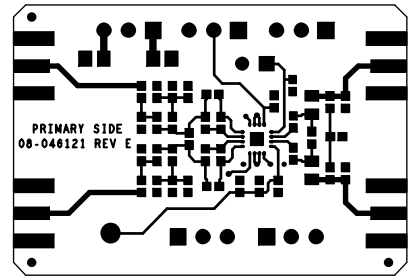

Figure 4. ADA4945-1CP-EBZ Evaluation Board Layout Pattern, Primary Side

ORDERING INFORMATION

BILL OF MATERIALS

Table 1. ADA4945-1CP-EBZ Bill of Materials

Quantity	Description	Reference Designation	Manufacturer	Part Number
1	High speed, ±0.1 μV/°C offset drift, fully differential ADC driver	U1	Analog Devices	ADA4945-1
5	0.1 μF ceramic capacitors, 0402	C7, C10 to C13	TDK	CGA2B1X7R1C104K050BC
2	10 μF tantalum capacitors, 0805	C8, C9	Taiyo Yuden	JMK212BJ106MG-T
6	0 Ω chip resistors, 0402	R1, R2, R7, R8, R11, R12	Panasonic	ERJ-2GE0R00X
4	499 Ω chip resistors, 0402	R5, R6, R9, R10	Panasonic	ERJ-2RKF4990X
2	56.2 Ω chip resistors, 0402	R3, R4	Panasonic	ERJ-2RKF56R2X
1	1 kΩ chip resistor, 0402	R26	Panasonic	ERJ-2RKF1001X
2	0 Ω chip resistors, 0805	L1, L2	Panasonic	ERJ-6GEY0R00V
1	Berg 2-pin header	PD	Amphenol	69157-102HLF
5	Berg 3-pin headers	P1 to P5	Samtec	TSW-103-08-G-S
2	Test point loops	VOCM	Components Corp.	TP-104-01-09
4	Connectors, side launch SMA	VINN, VINP, VOUTN, VOUTP	Samtec	SMA-J-P-H-ST-EM1
13	Chip resistors, 0402, do not install (DNI)	R13 to R25	Not applicable	Not applicable
6	Ceramic capacitors, 0402, DNI	C1 to C6	Not applicable	Not applicable



ESD Caution

ESD (electrostatic discharge) sensitive device. Charged devices and circuit boards can discharge without detection. Although this product features patented or proprietary protection circuitry, damage may occur on devices subjected to high energy ESD. Therefore, proper ESD precautions should be taken to avoid performance degradation or loss of functionality.

Legal Terms and Conditions

By using the evaluation board discussed herein (together with any tools, components documentation or support materials, the "Evaluation Board"), you are agreeing to be bound by the terms and conditions set forth below ("Agreement") unless you have purchased the Evaluation Board, in which case the Analog Devices Standard Terms and Conditions of Sale shall govern. Do not use the Evaluation Board until you have read and agreed to the Agreement. Your use of the Evaluation Board shall signify your acceptance of the Agreement. This Agreement is made by and between you ("Customer") and Analog Devices, Inc. ("ADI"), with its principal place of business at One Technology Way, Norwood, MA 02062, USA. Subject to the terms and conditions of the Agreement, ADI hereby grants to Customer a free, limited, personal, temporary, non-exclusive, non-sublicensable, non-transferable license to use the Evaluation Board FOR EVALUATION PURPOSES ONLY. Customer understands and agrees that the Evaluation Board is provided for the sole and exclusive purpose referenced above, and agrees not to use the Evaluation Board for any other purpose. Furthermore, the license granted is expressly made subject to the following additional limitations: Customer shall not (i) rent, lease, display, sell, transfer, assign, sublicense, or distribute the Evaluation Board; and (ii) permit any Third Party to access the Evaluation Board. As used herein, the term "Third Party" includes any entity other than ADI, Customer, their employees, affiliates and in-house consultants. The Evaluation Board is NOT sold to Customer; all rights not expressly granted herein, including ownership of the Evaluation Board, are reserved by ADI. CONFIDENTIALITY. This Agreement and the Evaluation Board shall all be considered the confidential and proprietary information of ADI. Customer may not disclose or transfer any portion of the Evaluation Board to any other party for any reason. Upon discontinuation of use of the Evaluation Board or termination of this Agreement, Customer agrees to promptly return the Evaluation Board to ADI. ADDITIONAL RESTRICTIONS. Customer may not disassemble, decompile or reverse engineer chips on the Evaluation Board. Customer shall inform ADI of any occurred damages or any modifications or alterations it makes to the Evaluation Board, including but not limited to soldering or any other activity that affects the material content of the Evaluation Board. Modifications to the Evaluation Board must comply with applicable law, including but not limited to the RoHS Directive. TERMINATION. ADI may terminate this Agreement at any time upon giving written notice to Customer. Customer agrees to return to ADI the Evaluation Board at that time. LIMITATION OF LIABILITY. THE EVALUATION BOARD PROVIDED HEREUNDER IS PROVIDED "AS IS" AND ADI MAKES NO WARRANTIES OR REPRESENTATIONS OF ANY KIND WITH RESPECT TO IT. ADI SPECIFICALLY DISCLAIMS ANY REPRESENTATIONS, ENDORSEMENTS, GUARANTEES, OR WARRANTIES, EXPRESS OR IMPLIED, RELATED TO THE EVALUATION BOARD INCLUDING, BUT NOT LIMITED TO, THE IMPLIED WARRANTY OF MERCHANTABILITY, TITLE, FITNESS FOR A PARTICULAR PURPOSE OR NON-INFRINGEMENT OF INTELLECTUAL PROPERTY RIGHTS. IN NO EVENT WILL ADI AND ITS LICENSORS BE LIABLE FOR ANY INCIDENTAL, SPECIAL, INDIRECT, OR CONSEQUENTIAL DAMAGES RESULTING FROM CUSTOMER'S POSSESSION OR USE OF THE EVALUATION BOARD, INCLUDING BUT NOT LIMITED TO LOST PROFITS, DELAY COSTS, LABOR COSTS OR LOSS OF GOODWILL. ADI'S TOTAL LIABILITY FROM ANY AND ALL CAUSES SHALL BE LIMITED TO THE AMOUNT OF ONE HUNDRED US DOLLARS (\$100.00). EXPORT. Customer agrees that it will not directly or indirectly export the Evaluation Board to another country, and that it will comply with all applicable United States federal laws and regulations relating to exports. GOVERNING LAW. This Agreement shall be governed by and construed in accordance with the substantive laws of the Commonwealth of Massachusetts (excluding conflict of law rules). Any legal action regarding this Agreement will be heard in the state or federal courts having jurisdiction in Suffolk County, Massachusetts, and Customer hereby submits to the personal jurisdiction and venue of such courts. The United Nations Convention on Contracts for the International Sale of Goods shall not apply to this Agreement and is expressly disclaimed.

©2019–2020 Analog Devices, Inc. All rights reserved. Trademarks and registered trademarks are the property of their respective owners. UG16985-8/20(A)



www.analog.com