

DO NOT SCALE DRAWING

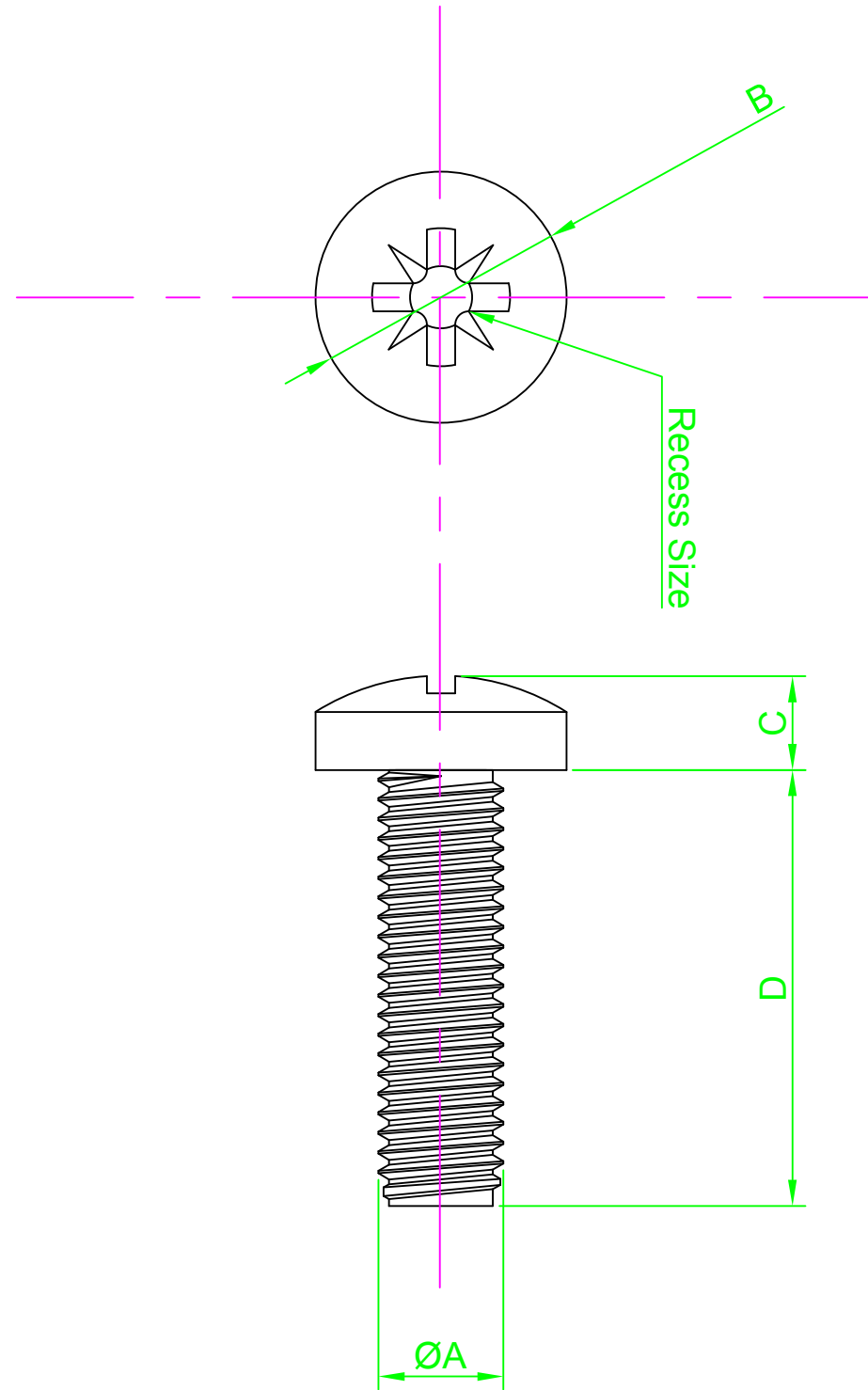
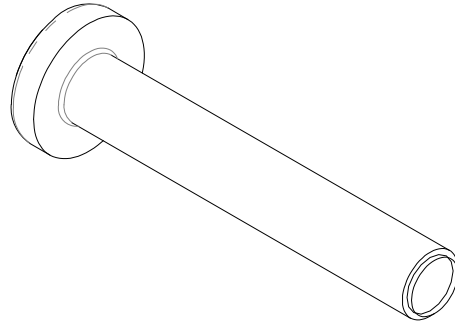

REVISION

A INITIAL DRAWING 21.9.15

Part Number	ØA	B Nom	C Nom	D Length	Recess Size
M2 6 PRA2MC S100	M2-0.4	4.0	1.6	6	Pozi #1
M2 12 PRA2MC S100				12	
M2.5 6 PRA2MC S100	M2.5-0.45	5.0	2.0	6	Pozi #1
M2.5 12 PRA2MC S100				12	
M3 6 PRA2MC S100	M3-0.5	6.0	2.4	6	Pozi #1
M3 10 PRA2MC S100				10	
M3 12 PRA2MC S100				12	
M3 16 PRA2MC S100				16	
M3 20 PRA2MC S100				20	
M4 6 PRA2MC S100	M4-0.7	8.0	3.1	6	Pozi #2
M4 10 PRA2MC S100				10	
M4 12 PRA2MC S100				12	
M4 16 PRA2MC S100				16	
M4 20 PRA2MC S100				20	
M4 25 PRA2MC S100				25	
M5 12 PRA2MC S100	M5-0.8	10.0	3.8	12	Pozi #2
M5 16 PRA2MC S100				16	
M5 20 PRA2MC S100				20	
M5 25 PRA2MC S100				25	
M6 12 PRA2MC S100	M6-1.0	12.0	4.8	12	Pozi #3
M6 16 PRA2MC S100				16	
M6 20 PRA2MC S100				20	
M6 25 PRA2MC S100				25	

NOTES:



UNLESS OTHERWISE SPECIFIED:
DIMENSIONS ARE IN MM (MILLIMETERS).
SURFACE FINISH:
TOLERANCES: DIN 7985

MATERIAL:
Stainless Steel A2

TITLE:
Pozi Pan Head Machine Screw DIN 7985

	NAME	DATE
DRAWN	Darryl Wilson	21.09.15
CHK'D		
APPVD		

HEAT TREATMENT:

DESIGN RIGHT. TR FASTENINGS LTD, 2003
UNDER NO CIRCUMSTANCES MUST THIS
DRAWING BE COPIED OR DISCLOSED
WITHOUT FIRST OBTAINING WRITTEN
AUTHORITY.

CUSTOMER PART NUMBER:
N/A

FINISH:
Self Finish

DRAWING NUMBER:
TR32PRA2MC

A4

PROJECTION

