

High-feed milling cutter

For indexable milling inserts: XCNT 120520..

ATORN®

Application

Dramatically increase your productivity and make great cost-savings – with the high-feed milling cutters. The unique cutting geometries provide extremely smooth running and low cutting forces at maximum feed rates. Our extensive program offers solutions for a wide range of applications in modern machine tools, whether in die and mould making or in general mechanical engineering.

Version

- Wear-resistant, nickel-plated version
- Robust supports
- With internal cooling
- Variable pitch
- Tightening torque (indexable insert) M3.5 = 3.5 Nm

Advantage

- Broad range of application
- Minimum-vibration milling even for long mounting lengths
- Optimum roughing tool
- Tooth feed possible up to 3 mm
- Reduces production times

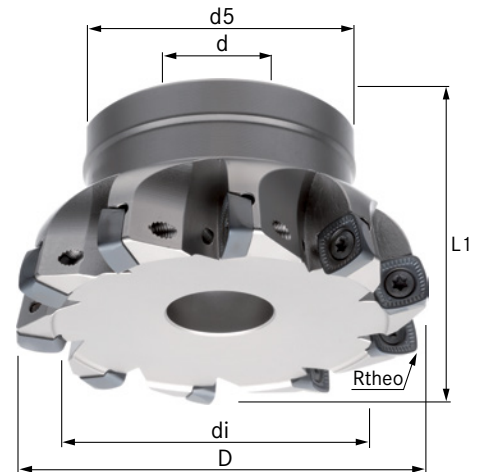

Art. No.	16026 261
Max. cutting edge diameter	42 mm
Min. cutting edge diameter	23 mm
Length	40 mm
Bore diameter	16 mm
Radius, theoretical	3.5 mm
max. ap	1.9 mm
Number of cutting edges	4 PCS
Suitable indexable insert no.	3

EAN-Code

4050293348637

