

NOTES:

1. RECOMMENDED SOLDER INSTRUCTION SEE SHEET 2
2. IP RATING: IP 67
3. SEALED TO WITHSTAND PRESSURE UP TO 1,45 PSI FOR 30 MINUTES AFTER SOLDERING
4. METAL SHELL: ZINC DIE CAST; min. 50µin NICKEL PLATING over COPPER
5. INSULATORS: PBT GF UL 94 V-0, BLACK
6. O-RING: SILICONE PER ASTM D2000 70 SHORE A
7. SEALING COMPOUND: EPOXY RESIN UL 94 V-0; BLACK
8. CONTACTS: COPPER ALLOY
PLATING (SEE PART NO):
 PLEASE ADD 1 for 30µin HARD GOLD over min. 50µin NICKEL
 PLEASE ADD 3 for 8µin HARD GOLD over min. 50µin NICKEL
 SOLDER CUP ACCEPTS CABLE AWG 20
9. HEXLOCKING SCREWS: STAINLESS STEEL
10. RECOMMENDED PANEL CUT-OUT ON SHEET 2
11. RECOMMENDED TORQUE FOR MOUNTING SCREW
35Ncm (3.1 in.LB) / max.67Ncm (6 in.LB)
12. CONNECTOR IS PART MARKED: 15-00063 CONEC ABC

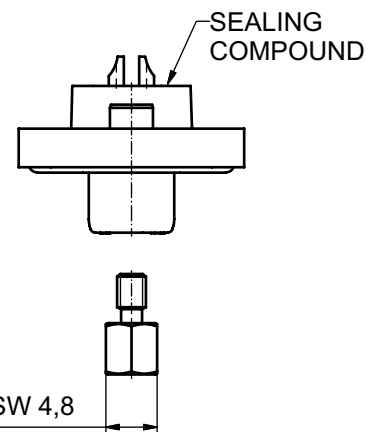

(b) AT ALL TIMES WATER RESISTANT CONNECTORS NOT IN USE SHOULD BE COVERED WITH A CONEC WATER RESISTANT CAP OR WATER TIGHT HOOD.

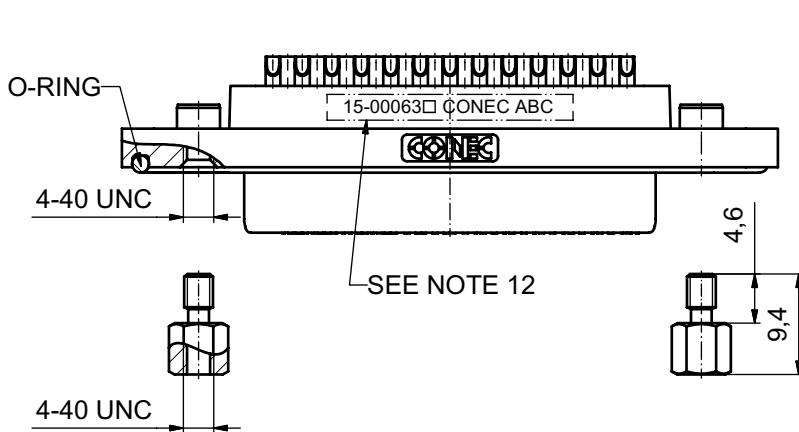
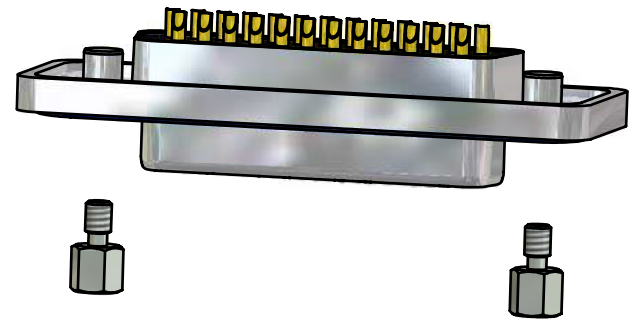
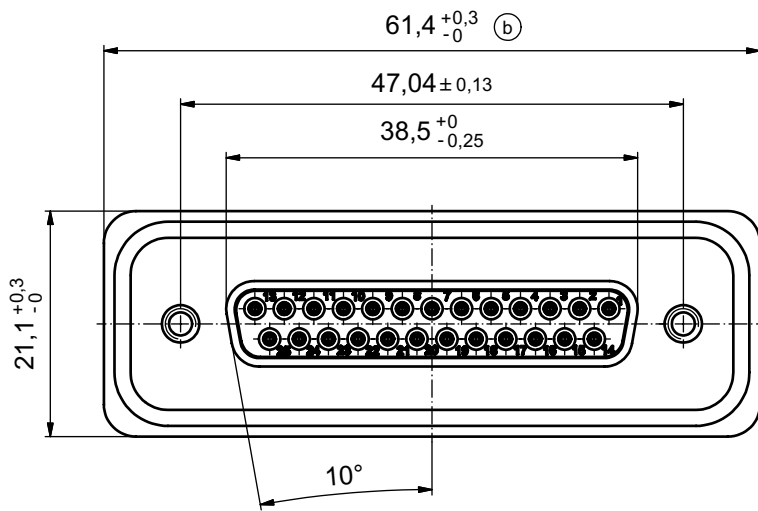
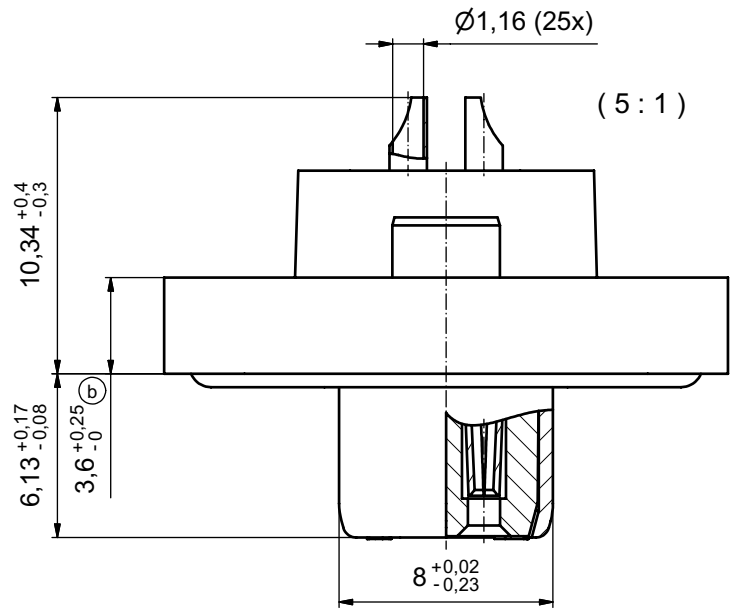

| | |
|---|--------|
| APPROVAL # FREIGABE # DEBLOCAGE # AUTORIZACION # APPROVAL | |
| CUSTOMER APPROVAL DATE: | |
| NAME: | TITLE: |
| COMPANY NAME: | |
| APPROVAL # FREIGABE # DEBLOCAGE # AUTORIZACION # APPROVAL | |

| | | | | | | | | |
|--|-------------|----------|------|--------------|----------|------------|--|--------|
| THIS DRAWING MAY NOT BE COPIED OR REPRODUCED IN ANY WAY, AND MAY NOT BE PASSED ON TO A THIRD PARTY WITHOUT WRITTEN PERMISSION. OWNERSHIP AND COPYRIGHT OF CONEC GmbH | | | | tolerance | | dim. in mm | scale: 2:1 (5:1) | |
| DO NOT ALTER CAD DRAWING BY HAND | | | | date | | | material: see notes | |
| 3 x b | A 3435 | 30.09.09 | HS | drawn | 17.10.08 | Petker | title: D-SUB FEMALE 25pos. SOLDER CUP with hexlocking screw | |
| a | Origin | | | appd. | 22.10.08 | Fischer | | |
| rev. | description | date | name | norm | | | | |
| | | | | d-old | | | dwg no: Inventor 10 | DIN-A3 |
| | | | | CONEC | | | sh: 1 | |
| | | | | | | | part no: 15-00063 <input type="checkbox"/> (see note 8) | |

| | | |
|---|--|--------|
| dwg no: Inventor 10 | | DIN-A3 |
| 15K1A294 | | sh: 1 |
| part no: 15-00063 <input type="checkbox"/> (see note 8) | | |

Solder Instruction

1. Cable should be prepared for soldering. The cable/wires must be pretinned.
2. Insert cable/wire into solder cup.
3. Operate the soldering iron at 350°C, 50 Watt max. and use a pencil tip.
4. Put tip to wire in solder cup.
5. After 1 second bring in solder.
6. Heat for 3 seconds longer. Do not heat contact more than 4 seconds in total.
7. Remove soldering iron.
8. Wait until solder gets rigid again.
9. Do not solder adjacent contacts consecutively, alternate position within the connector to minimize heat build up.

RECOMMENDED PANEL CUT-OUT

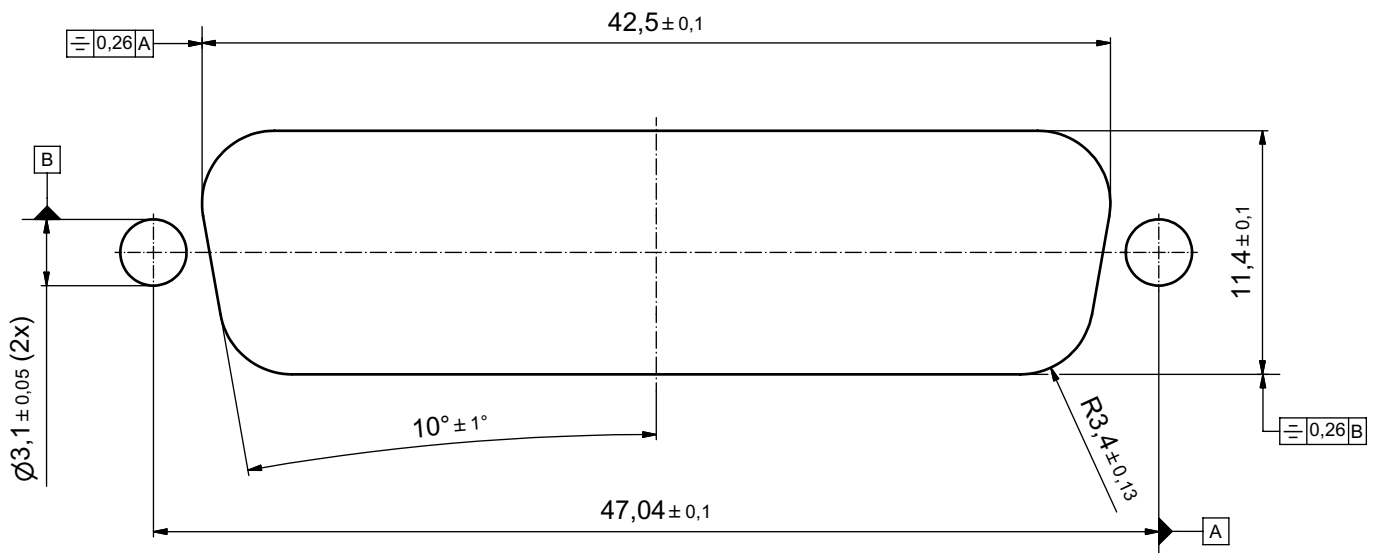

| | |
|---|--------|
| APPROVAL # FREIGABE # DEBLOCAGE # AUTORIZACION # APPROVAL | |
| CUSTOMER APPROVAL DATE: | |
| NAME: | TITLE: |
| COMPANY NAME: | |
| APPROVAL # FREIGABE # DEBLOCAGE # AUTORIZACION # APPROVAL | |

| | | | | | | |
|--|-------------|------|------|-----------|------------------|------------|
| THIS DRAWING MAY NOT BE COPIED OR REPRODUCED IN ANY WAY, AND MAY NOT BE PASSED ON TO A THIRD PARTY WITHOUT WRITTEN PERMISSION. OWNERSHIP AND COPYRIGHT OF CONEC GmbH DO NOT ALTER CAD DRAWING BY HAND | | | | tolerance | | dim. in mm |
| | | | | date | name | |
| | | | | drawn | 17.10.08 Petker | |
| | | | | appd. | 22.10.08 Fischer | |
| norm | | | | | | |
| d-old | | | | | | |
| a | Origin | | | | | |
| rev. | description | date | name | | | |

| | |
|---|--------|
| scale: 4:1 | |
| material: see sheet 1 | |
| title: PANEL CUT-OUT D-SUB FEMALE 25pos. SOLDER CUP with hexlocking screw | |
| dwg no: Inventor 10 | DIN-A3 |
| 15K1A294 | |
| part no: see sheet 1 | sh: 2 |

