

DO NOT SCALE DRAWING

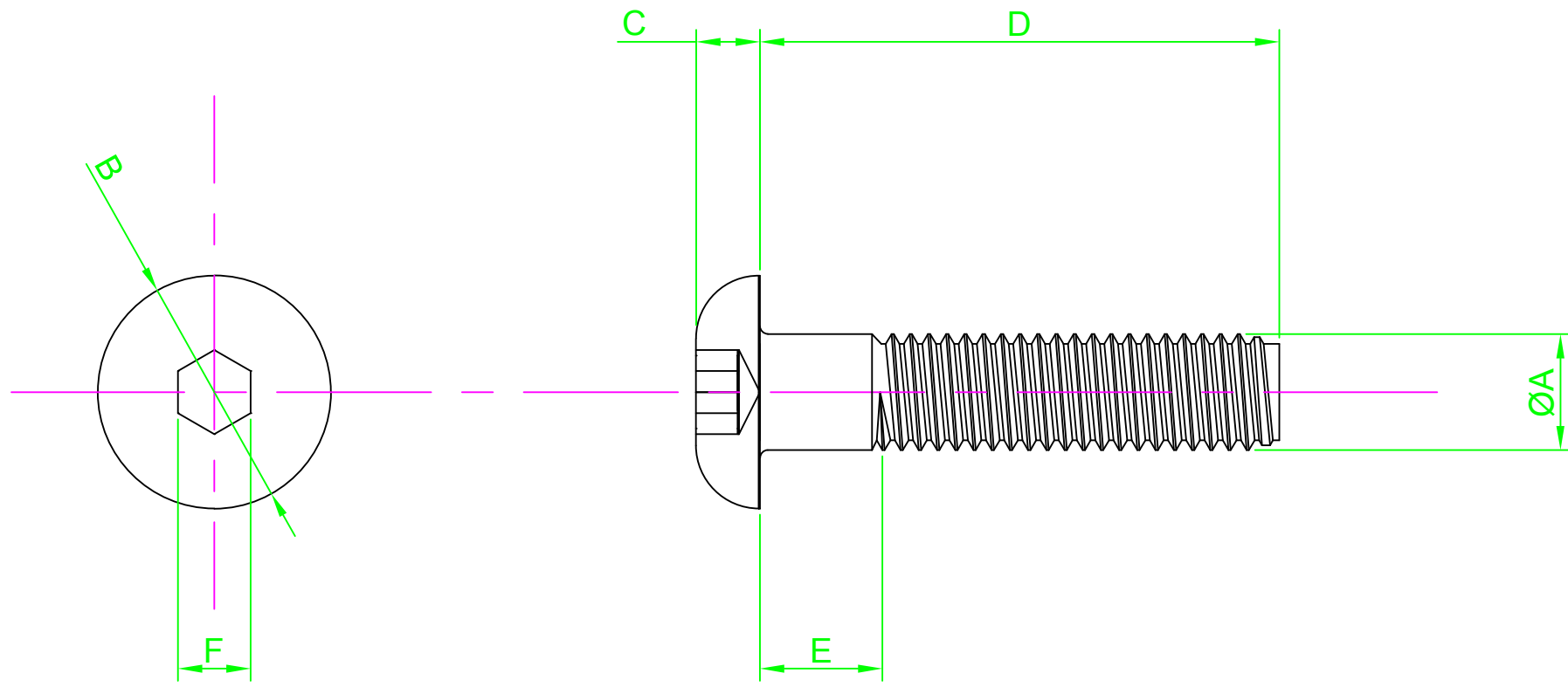

REVISION

A INITIAL DRAWING 08.01.2016

Part Number	ØA	B Max	C Max	D Length	E Max	F Ref
M3 5 BH10MC S100	M3-0.5	5.7	1.65	5	1.5	2
M3 8 BH10MC S100				8		
M3 10 BH10MC S100				10		
M3 12 BH10MC S100				12		
M4 6 BH10MC S100	M4-0.7	7.6	2.2	6	2.1	2.5
M4 8 BH10MC S100				8		
M4 10 BH10MC S100				10		
M4 12 BH10MC S100				12		
M4 16 BH10MC S100				16		
M4 20 BH10MC S100	20					
M5 8 BH10MC S100	M5-0.8	9.5	2.75	8	2.4	3
M5 10 BH10MC S100				10		
M5 12 BH10MC S100				12		
M5 16 BH10MC S100				16		
M5 20 BH10MC S100	20					
M6 10 BH10MC S100	M6-1.0	10.5	3.3	10	3.0	4
M6 12 BH10MC S100				12		
M6 16 BH10MC S100				16		
M6 20 BH10MC S100				20		
M6 30 BH10MC S100				30		

NOTES:



DESIGN RIGHT. TR FASTENINGS LTD, 2003
 UNDER NO CIRCUMSTANCES MUST THIS
 DRAWING BE COPIED OR DISCLOSED
 WITHOUT FIRST OBTAINING WRITTEN
 AUTHORITY.

UNLESS OTHERWISE SPECIFIED:
 DIMENSIONS ARE IN MM (MILLIMETERS).
 SURFACE FINISH:
 TOLERANCES: ISO 7380

	NAME	DATE
DRAWN	Darryl Wilson	08.01.16
CHK'D		
APPV'D		

MATERIAL:
 Steel

HEAT TREATMENT:
 Grade 10.9

FINISH:
 Self Finish

TITLE:
 Socket Button Head Machine Screw ISO7380

DRAWING NUMBER:
 TR32BH10MC-S100

A4

