

LEGRABOX pure  
LEGRABOX free

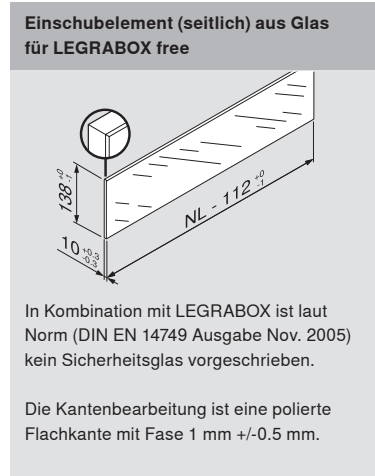

## Frontauszug – Höhe C

### Planung

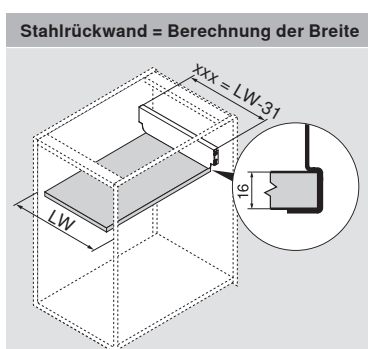
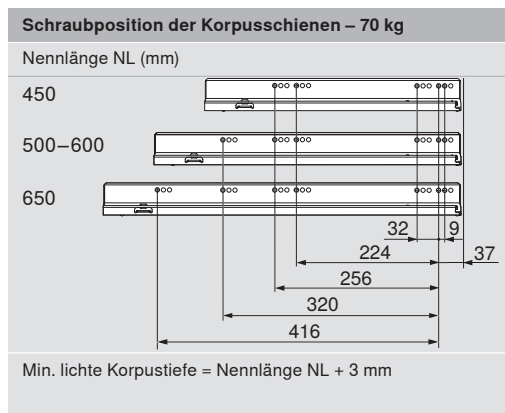
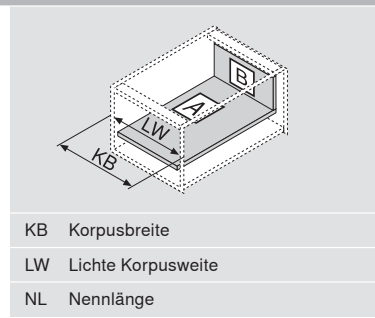
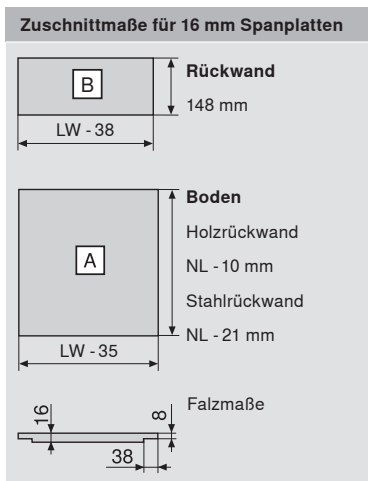
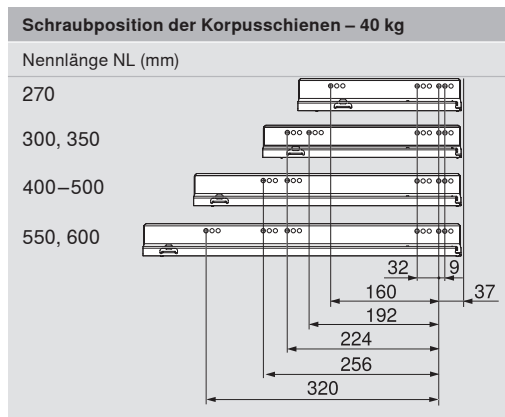
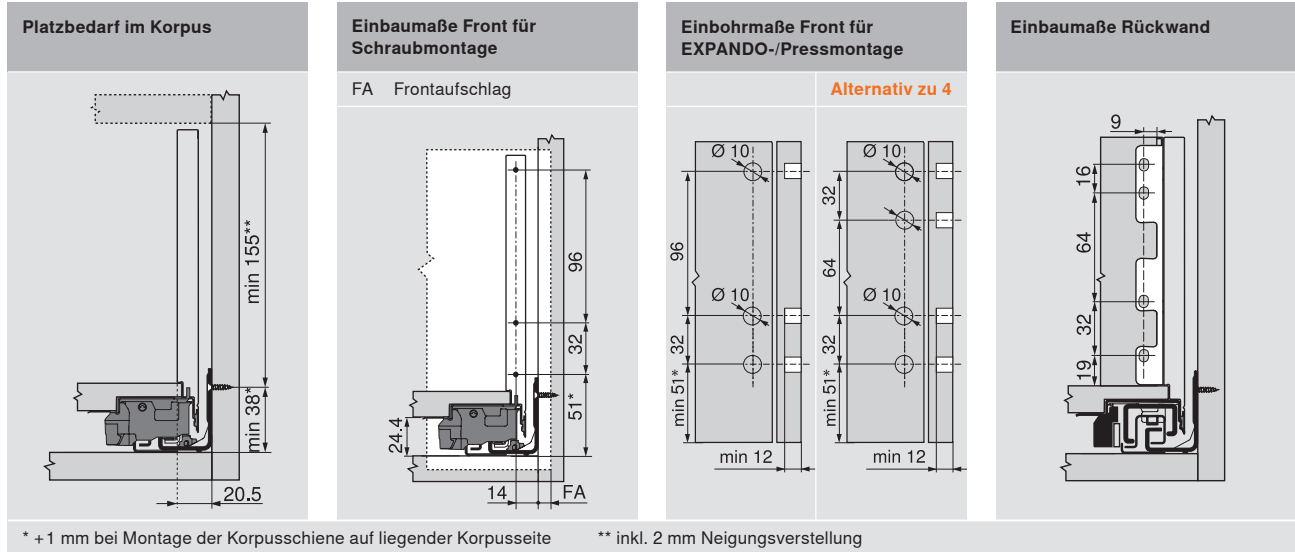

Seitenhinweise			
Zubehör – Synchronisierung für TIP-ON	53	Zubehör – TORX-Schraubendreher	55
Zubehör – Seitenstabilisierung	54	Befestigung der Korpuschiene	56
Zubehör – Frontstabilisierung	54	Montage, Demontage und Einstellung	58