

Features

- Push switch option
- Compact, rugged design
- High reliability
- Metal bushing/shaft



PEC11R Series - 12 mm Incremental Encoder

Electrical Characteristics

Output.....	2-bit quadrature code
Contact Rating.....	10 mA @ 5 VDC
Insulation Resistance.....	100 megohms @ 250 VDC
Dielectric Withstanding Voltage	
Sea Level.....	300 VAC minimum
Electrical Travel.....	Continuous
Contact Bounce (15 RPM).....	2.0 ms maximum**
RPM (Operating).....	60 maximum**

Environmental Characteristics

Operating Temperature Range.....	-30 °C to +70 °C (-22 °F to +158 °F)
Storage Temperature Range.....	-40 °C to +85 °C (-40 °F to +185 °F)
Humidity.....	MIL-STD-202, Method 103B, Condition B
Vibration.....	10~55~10 Hz / 1 min. / Amplitude 1.5 mm
Shock.....	100 G
Rotational Life.....	30,000 cycles minimum
Switch Life.....	20,000 cycles minimum
IP Rating.....	IP 40

Mechanical Characteristics

Mechanical Angle.....	360 ° continuous
Torque	
Detent.....	30 to 90 gf-cm (0.41 to 1.25 oz-in)
Running.....	10 to 70 gf-cm (0.14 to 0.97 oz-in)
Mounting.....	10.2 kgf.cm (8.83 lb.-in.) maximum
Shaft Side Load (Static).....	2.04 kgf (4.5 lbs.) minimum
Weight.....	5 gm (0.17 oz.) maximum
Terminals.....	Printed circuit board terminals
Soldering Condition	
Wave Soldering.....	Sn95.5/Ag2.8/Cu0.7 solder with no-clean flux: 260 °C max. for 3 ±1 sec.
Hand Soldering.....	Not recommended
Hardware.....	One flat washer and one mounting nut supplied with each encoder

Switch Characteristics

Switch Type.....	Contact Push ON Momentary SPST
Power Rating (Resistive Load).....	10 mA at 5 V DC
Switch Travel.....	0.5 ± 0.3 mm
Switch Actuation Force.....	610 ± 306 gf (8.47 ± 4.24 oz.-in.)
Contact Resistance.....	100 milliohms @ 5 VDC

How To Order

PEC11R - 4 0 20 F - S 0012

Model.....	PEC11R - 4 0 20 F - S 0012
Terminal Configuration.....	4 = PC Pin Horizontal/Rear Facing
Detent Option.....	0 = No Detents (12, 18, 24 pulses) 1 = 18 Detents (18 pulses) 2 = 24 Detents (12, 24 pulses) 3 = 12 Detents (12, 24 pulses)
Standard Shaft Length.....	15 = 15.0 mm 20 = 20.0 mm 25 = 25.0 mm 30 = 30.0 mm
Shaft Style.....	F = Metal Flatted Shaft K = Metal Knurled Shaft ¹
Switch Configuration.....	S = Push Momentary Switch N = No Switch
Resolution.....	0012 = 12 Pulses per 360 ° Rotation 0018 = 18 Pulses per 360 ° Rotation 0024 = 24 Pulses per 360 ° Rotation

¹ Metal knurled shaft without switch is available in 15, 20 and 30 mm shaft lengths.
Metal knurled shaft with push momentary switch is available in 15 and 20 mm shaft lengths.

Quadrature Output Table

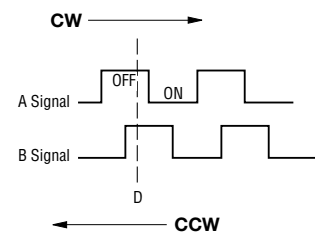

*RoHS Directive 2002/95/EC Jan. 27, 2003 including annex and RoHS Recast 2011/65/EU June 8, 2011.

**Devices are tested using standard noise reduction filters. For optimum performance, designers should use noise reduction filters in their circuits.

Specifications are subject to change without notice.

The device characteristics and parameters in this data sheet can and do vary in different applications and actual device performance may vary over time.

Users should verify actual device performance in their specific applications.

Applications

Level control, tuning and timer settings in:

- Audio-visual equipment
- Consumer electric appliances
- Radios
- Musical instrumentation
- Communications equipment

PEC11R Series - 12 mm Incremental Encoder

BOURNS®

Product Dimensions

PEC11R-4xxxF-Nxxxx

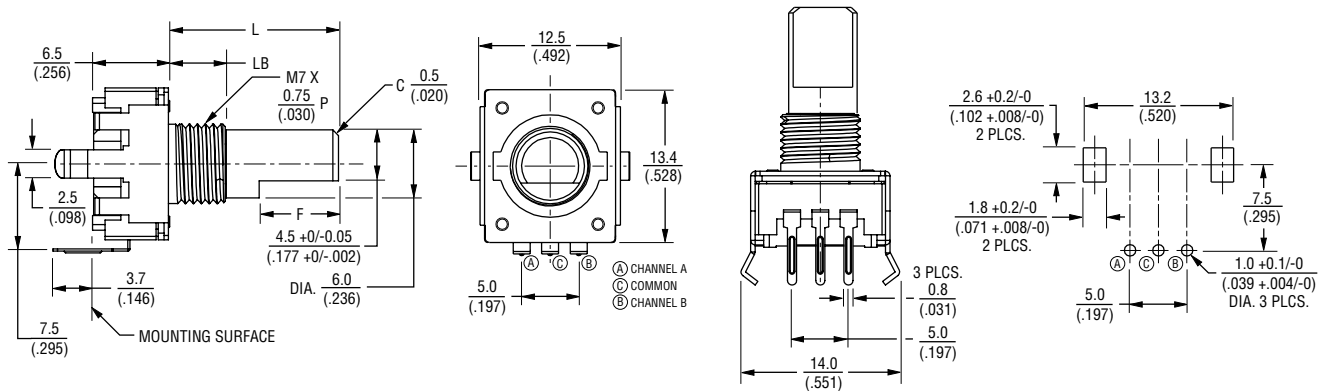

PEC11R-4xxxF-Sxxxx

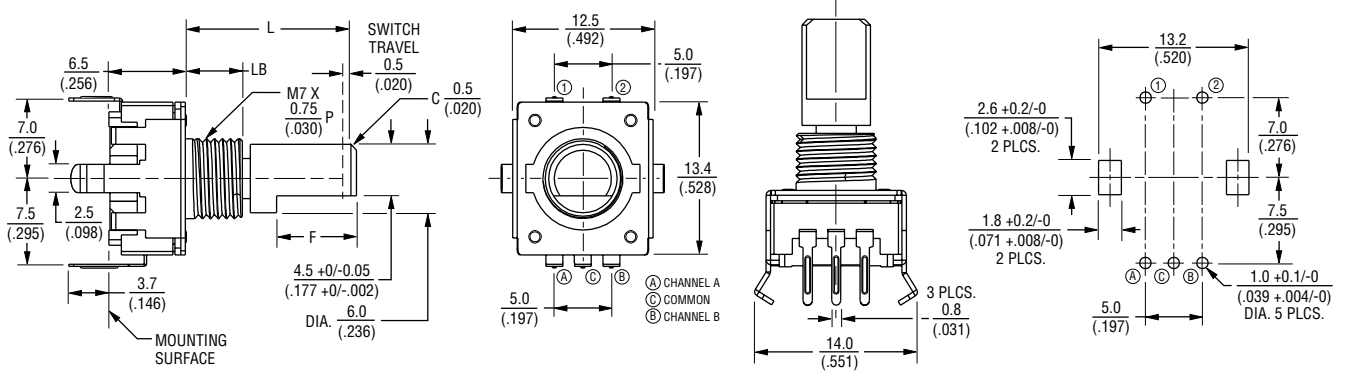

L	LB	F
15 (.591)	5.0 (.197)	7.0 (.276)
20 (.787)	7.0 (.276)	10.0 (.394)
25 (.984)	7.0 (.276)	12.0 (.472)
30 (1.181)	7.0 (.276)	12.0 (.472)

Switch Circuit



Suggested Filter Circuit

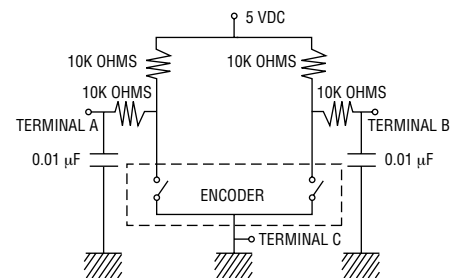

DIMENSIONS: $\frac{\text{MM}}{\text{(INCHES)}}$

TOLERANCES: $< \frac{10}{(.394)} = \pm \frac{0.3}{(.012)}$
 $\geq \frac{10}{(.394)} = \pm \frac{0.5}{(.020)}$

Specifications are subject to change without notice. The device characteristics and parameters in this data sheet can and do vary in different applications and actual device performance may vary over time. Users should verify actual device performance in their specific applications.

PEC11R Series - 12 mm Incremental Encoder

BOURNS®

Product Dimensions

PEC11R-4xxxK-Nxxxx

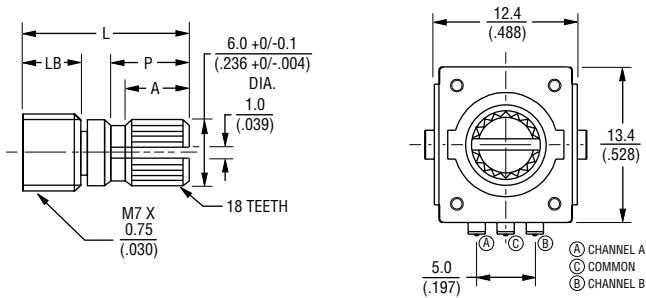

L	LB	P	A
15 (.591)	5.0 (.197)	7.0 (.276)	6.0 (.236)
20 (.787)	7.0 (.276)	7.0 (.276)	6.0 (.236)
30 (1.181)	7.0 (.276)	16.0 (.630)	12.0 (.472)

PEC11R-4xxxK-Sxxxx

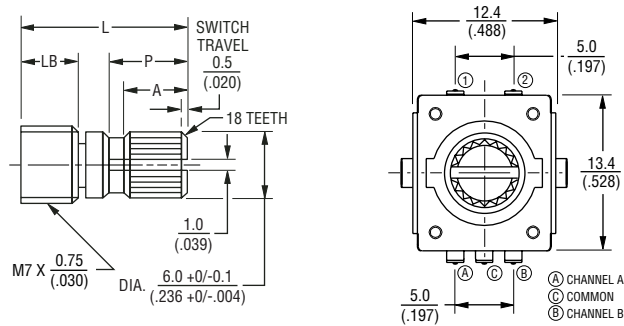

L	LB	P	A
15 (.591)	5.0 (.197)	7.0 (.276)	6.0 (.236)
20 (.787)	7.0 (.276)	7.0 (.276)	6.0 (.236)

DIMENSIONS: $\frac{\text{MM}}{\text{(INCHES)}}$

TOLERANCES: $< \frac{10}{(.394)} = \pm \frac{0.3}{(.012)}$
 $\geq \frac{10}{(.394)} = \pm \frac{0.5}{(.020)}$

REV. 11/16

Specifications are subject to change without notice.

The device characteristics and parameters in this data sheet can and do vary in different applications and actual device performance may vary over time. Users should verify actual device performance in their specific applications.