

MICROPROCESSOR-BASED SLOT SENSOR FOR TRANSPARENT LABEL DETECTION

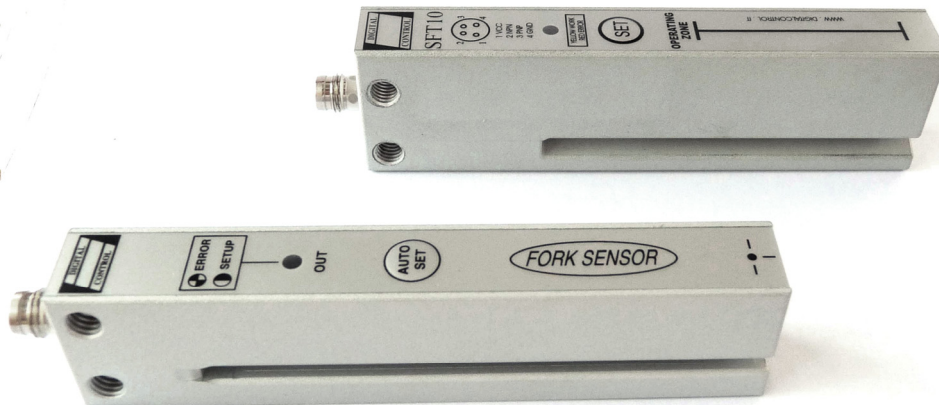
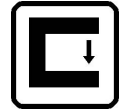

- **High 10 kHz switching frequency**
- **Unique capacitive technology**
- **One touch teach system**
- **Detection of Transparent labels**
- **Both NPN and PNP outputs**

SFT10-3 SERIES

The sensor SFT10-3 has been developed to reliably detect transparent labels and its specification means that it will work with virtually all labels.

The labels

The SFT10-3 works with any type of label even those with a metallic finish without any of the problems you normally experience with other clear label sensors.

Easy setting

The setting of SFT10-3 is simplicity itself. The operator must only teach the sensor the label on the liner/support and the SFT10-3 will do the rest.

The outputs

The SFT10-3 offers two outputs PNP and NPN, which are both protected from short circuit and overload.

The functionality

The SFT10-3 can be set to work in 4 modes which are selectable on power up: light or dark, as well as a single or double label detection to manage the latest clear labels with cut outs. The extremely fast response time eliminates the usual problem of loss of precision at high speed.

The installation

The SFT10-3 is easy to install with two M5 threaded holes. The electrical connection and mechanical fixing is compatible with those of the base SF30, therefore it is possible to replace the SF30 with the SFT10-3 when working with transparent labels that are impossible to detect with an optical sensor.

TECHNICAL SPECIFICATION

- Power supply:** 12 to 30 Vdc (reverse polarity protected)
 - Current Consumption:** 30 mA max (plus load current)
 - Output:** PNP and NPN (with short circuit protection)
 - Max load:** 100 mA max
 - Response time:** 50 μ s
 - Max size of label:** Thickness max. 0.8 mm, min. distance between labels 1mm.
 - Dimensions:** 10 x 30 x 15 mm
 - Distance between mounting holes:** ... 15 mm
 - Housing:** Anodized aluminium with polycarbonate label
 - Connector:** M8 male 4 Pole
 - Indicator:** Yellow led for active output signal, red for alarm
 - Setting:** Push Button teach
 - Operation modality:** Light, dark, single or double label
- Patent request N°AT2007A000008

DIMENSIONS

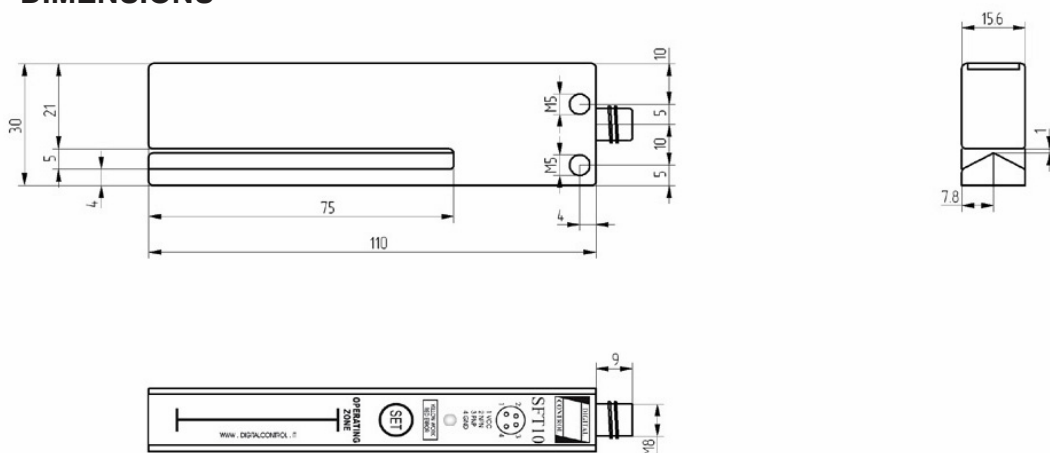

CONNECTIONS

