

FICHA TÉCNICA – TECHNICAL DATA SHEET: SPE 38x40

VENTAJAS – BENEFITS

- Sistema patentado. Fijación directa al perfil - **Patented system. Direct fixing to the channel.**
- Huella regular. Facilita el corte y el cálculo de las distancias - **Sizeable holes. Facilitate the cutting and distance calculation.**
- Agujeros reducidos. Limita la merma en el corte - **Small hole. Limited waste of material.**
- Versátiles. Permite el montaje por ambos lados - **Versatile. Two sides for installation.**
- Troquelado doble: coliso para montaje estándar con EPR y agujero para el montaje de tornillos FT - **Two holes: connection hole for standard installation with EPR and round hole for FT screw installation.**
- Fabricación propia. Calidad garantizada - **National production. Guaranteed quality.**
- Homologado – **homologated.**
- Coliso final para el refuerzo bajo techo - **Oval final hole. To reinforce the support under the ceiling.**



Foto Producto /
Product photo



Homologaciones/
approvals



APLICACIONES – APPLICATIONS.

Montaje de bandeja metálica de rejilla y troquelada - **Cable tray (perforated and wire) installation.**

Montaje de abrazaderas M8 y M6 - **M8 and M6 clamp installation.**



Este documento es propiedad de Apolo. Cualquier copia total o parcial está prohibida excepto autorización escrita de Apolo /This document is intellectual property of apolo. Copy is forbidden and will be prosecuted. Copy, total or partial, must have the written agreement of apolo.

TDS-1

CARACTERÍSTICAS – FEATURES

Material / *Material*

- Fabricado en acero cincado mínimo 5 micras - *Manufactured using White zinc plated, minimum 5 microns.*

Cotas principales (mm) - *Main dimensions (mm)*

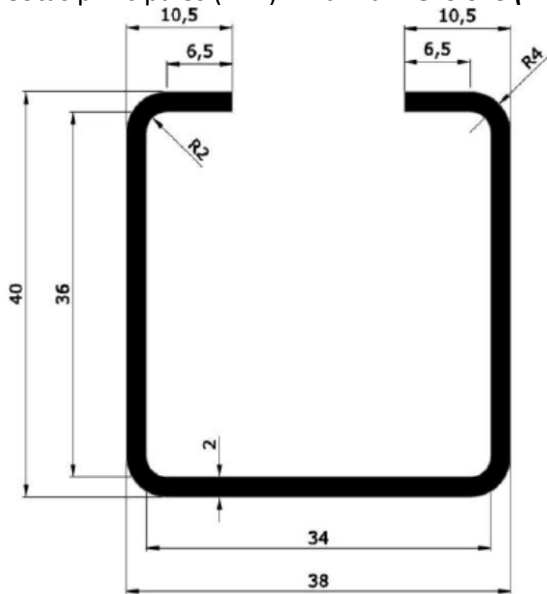

REF	Medidas Generales <i>General Sizes</i> mm	Sección	Momento inercia		Momento resistente	
		<i>Section</i> cm ²	<i>Inertia</i> I_y mm ⁴	I_x mm ⁴	<i>Resistant torque</i> W_y mm ³	W_x mm ³
38x40	38x40x2	251,65	36.131	60.582	2.073	3.188

Grosor de la pletina – *sheet Thickness* = 5mm.

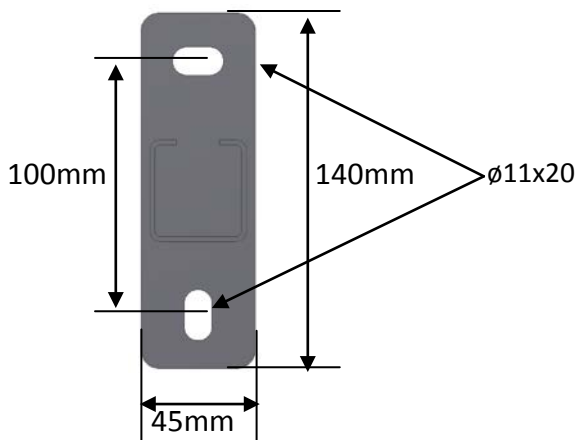

Este documento es propiedad de Apolo. Cualquier copia total o parcial está prohibida excepto autorización escrita de Apolo / *This document is intellectual property of apolo. Copy is forbidden and will be prosecuted. Copy, total or partial, must have the written agreement of apolo.*

TDS-2

Troquelado – Die holes.

Agujero de $\varnothing 6$ con coliso final $\varnothing 8 \times 25$ (centro $\varnothing 10$) - **Round hole $\varnothing 6$ and final connection hole of $\varnothing 8 \times 25$ (center $\varnothing 10$)**

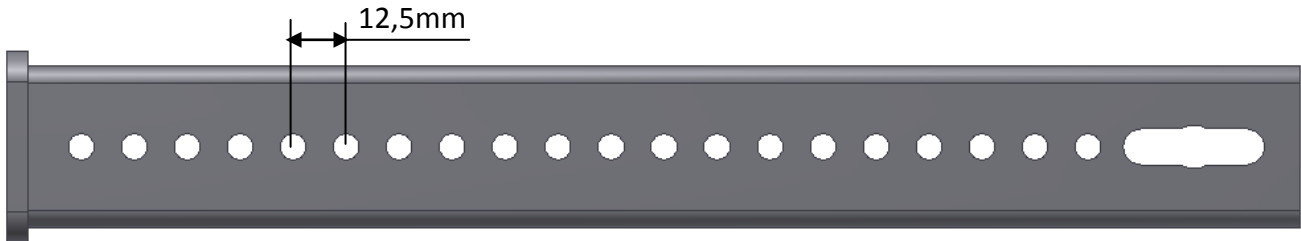

PROCEDIMIENTO DE INSTALACIÓN / INSTALLATION PROCEDURE

Instalación eléctrica – Electrical installation

Fijación directa de abrazaderas con FT M7x20 – **Direct fixing to support with FT M7x20**

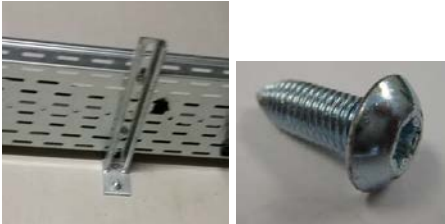

Instalación sanitaria – Plumbing installation.

Fijación directa de abrazaderas con TORAB FT o EPR – **Direct fixing to support with TORAB FT o EPR.**



PARÁMETROS DE INSTALACIÓN / INSTALLATION PARAMETERS

Analizar la carga recomendada del soporte perfil para determinar la separación entre ellos – Analyze the recommended load of the channel to decide the maximum space between them.

MATERIALES BASE* / BASE MATERIAL*

Hormigón / **Concrete**

Bloque hormigón / **Concrete block**

Ladrillo macizo / **Solid brick**

Acero / **Steel**

*depende del sistema de fijación / **depending on fixing system.**

Este documento es propiedad de Apolo. Cualquier copia total o parcial está prohibida excepto autorización escrita de Apolo / **This document is intellectual property of apolo. Copy is forbidden and will be prosecuted. Copy, total or partial, must have the written agreement of apolo.**

CARGAS RECOMENDADAS / RECOMMENDED LOADS.

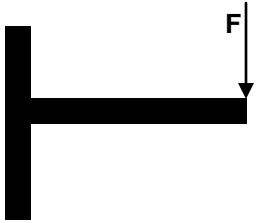
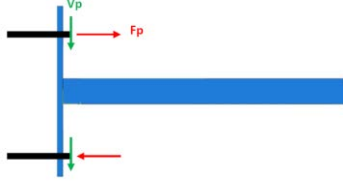
SOPORTE	Carga Recomendada en Kg según Tipo de Carga <i>Recommended load (Kg) according to load type</i>	Reacciones en los apoyos para el máximo de carga <i>Reaction (Kg) on the support at recommended load</i>	
			
		Vp	Fp
38x40x200	230,4	115,2	301,1
38x40x300	146,6	73,3	301,1
38x40x400	107,5	53,8	301,1
38x40x500	84,9	42,5	301,1
38x40x600	69,3	34,6	297,3

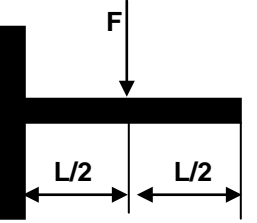
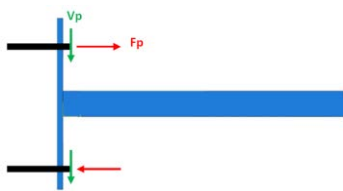
SOPORTE	Carga Recomendada en Kg según Tipo de Carga <i>Recommended load (Kg) according to load type</i>	Reacciones en los apoyos para el máximo de carga <i>Reaction (Kg) on the support at recommended load</i>	
			
		Vp	Fp
38x40x200	466,6	233,4	610,0
38x40x300	297,1	148,6	610,0
38x40x400	217,9	108,9	610,0
38x40x500	169,8	84,9	602,2
38x40x600	140,3	70,1	602,2

Valores para una flecha máxima de L/150 - *Values for a maximum channel deformation of L/150.*

σ_{perm} 160N/mm² -