

Drain Separator for Vacuum  
**Series AMJ**



**Remove water droplets from air by simply installing in vacuum equipment connection lines. Effective for removing water droplets from the air sucked into vacuum pumps and ejectors, etc.**

# Drain Separator for Vacuum

## Series *AMJ*

Over 90% of droplets can be removed through the use of a special water droplet removing element.

The provision of a drain cock makes it possible to discharge the drain manually after breaking the vacuum.

Even when the element is saturated with water, there is almost no drop in pressure (increase in resistance).

The element can be replaced with a single touch.



### How to Order

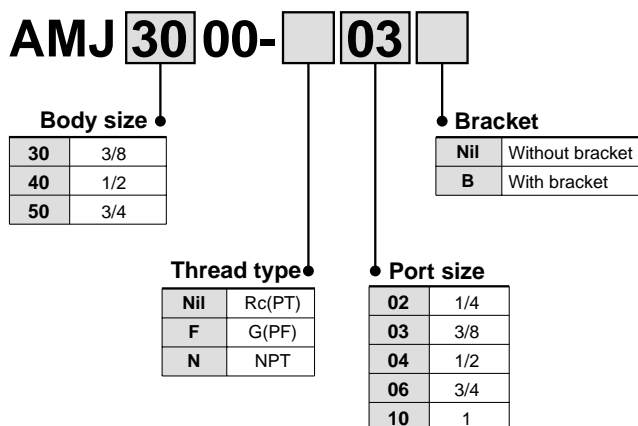

### Models

Model	AMJ3000	AMJ4000	AMJ5000
Recommended flow rate $\ell$ /min (ANR)	200	300	500
Port size (nominal size B)	1/4, 3/8	3/8, 1/2	3/4, 1
Weight (kg)	0.3	0.6	1.1

### Specifications

Fluid	Air
Maximum operating pressure	1.0MPa {10.2kgf/cm <sup>2</sup> }
Minimum operating pressure	-750mmHg
Proof pressure	1.5MPa {15.3kgf/cm <sup>2</sup> }
Ambient & fluid temperature	5 to 60°C
Water drop removal ratio	90%
Element life	2 years or when pressure drops by 0.02MPa {0.2kgf/cm <sup>2</sup> }

### Accessories (Optional)

Applicable model	AMJ3000	AMJ4000	AMJ5000
Bracket assembly (with 2 mounting screws)	B340A	B440A	B640A

# Drain Separator for Vacuum *Series AMJ*

## Flow Rate Characteristics

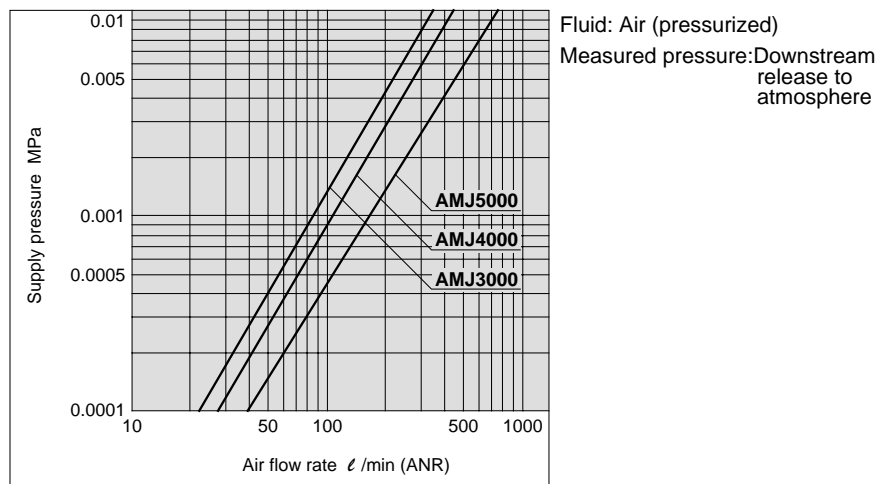

## Construction

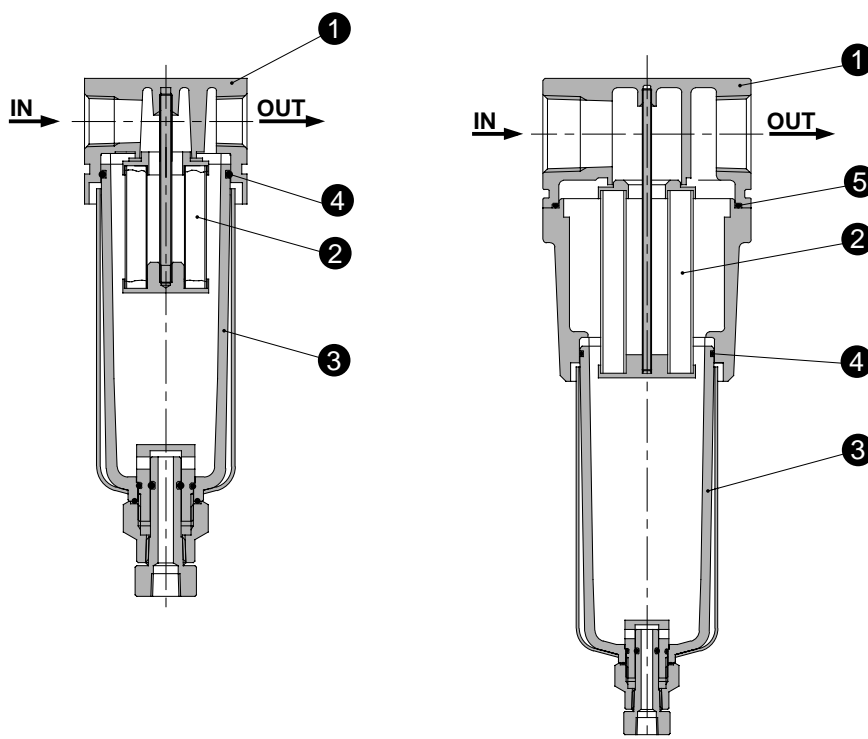

### Parts list

No.	Description	Material	Note
①	Body	Die-cast aluminum	Platinum silver coating

### Replacement parts

No.	Description	Material	Part No.		
			AMJ3000	AMJ4000	AMJ5000
②	Element assembly		AMJ-EL3000	AMJ-EL4000	AMJ-EL5000
③	Case assembly <sup>(Note)</sup>	Polycarbonate	AMJ-CA3000-A	AMJ-CA4000-A	AMJ-CA5000-A
④	O-ring	NBR	111512	111636	111636
⑤	O-ring	NBR	-	-	111710

(Note) The case assembly includes a case guard (material: SPCE).

# Series AMJ

## Dimensions

### AMJ3000, 4000

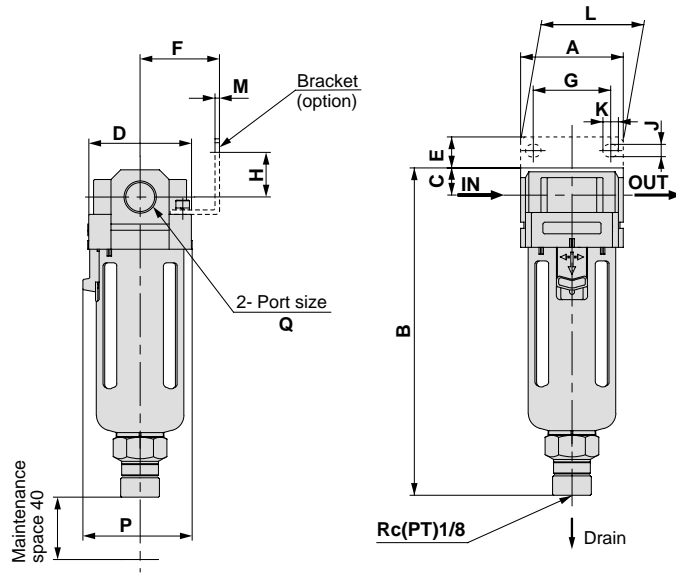

### AMJ5000

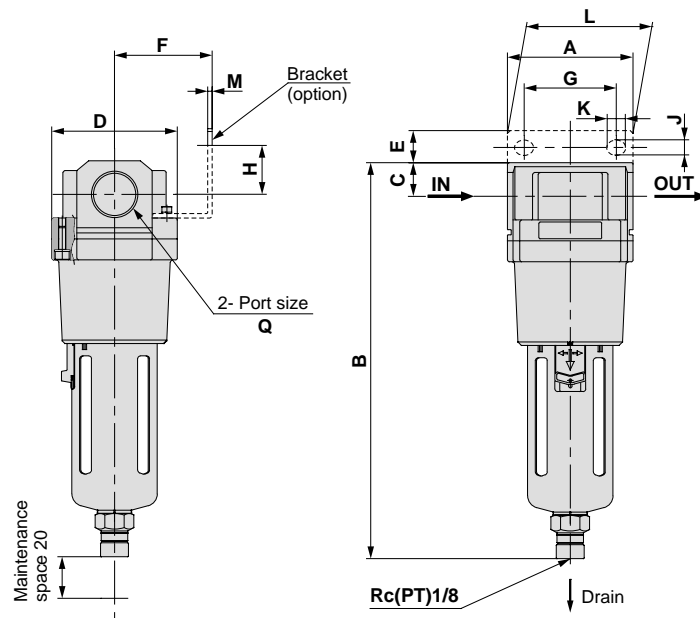

(mm)

Model	Port size Q	A	B	C	D	Bracket mounting dimensions								P
						E	F	G	H	J	K	L	M	
AMJ3000	Rc(PT)1/4, 3/8	53	169	14	53	16	41	40	23	6.5	8	53	2.3	56
AMJ4000	Rc(PT)3/8, 1/2	70	205	18	70	17	50	54	26	8.5	10.5	70	2.3	73
AMJ5000	Rc(PT)3/4, 1	90	284	24	90	23	70	66	35	11	13	90	3.2	-





**Series AMJ**

# Safety Instructions

These safety instructions are intended to prevent a hazardous situation and/or equipment damage. These instructions indicate the level of potential hazard by a label of "**Caution**", "**Warning**" or "**Danger**". To ensure safety, be sure to observe ISO 4414 Note 1), JIS B 8370 Note 2) and other safety practices.

 **Caution** : Operator error could result in injury or equipment damage.

 **Warning** : Operator error could result in serious injury or loss of life.

 **Danger** : In extreme conditions, there is a possible result of serious injury or loss of life.

Note 1) ISO 4414 : Pneumatic fluid power – Recommendations for the application of equipment to transmission and control systems.

Note 2) JIS B 8370 : Pneumatic system axiom.

## **Warning**

### **1 The compatibility of pneumatic equipment is the responsibility of the person who designs the pneumatic system or decides its specifications.**

Since the products specified here are used in various operating conditions, their compatibility for the specific pneumatic system must be based on specifications or after analysis and/or tests to meet your specific requirements.

### **2 Only trained personnel should operate pneumatically operated machinery and equipment.**

Compressed air can be dangerous if an operator is unfamiliar with it. Assembly, handling or repair of pneumatic systems should be performed by trained and experienced operators.

### **3 Do not service machinery/equipment or attempt to remove components until safety is confirmed.**

1. Inspection and maintenance of machinery/equipment should only be performed after confirmation of safe locked-out control positions.
2. When equipment is to be removed, confirm the safety process as mentioned above. Cut the supply pressure for this equipment and exhaust all residual compressed air in the system.
3. Before machinery/equipment is re-started, take measures to prevent shooting-out of cylinder piston rod, etc. (Bleed air into the system gradually to create back-pressure.)

### **4 Contact SMC if the product is to be used in any of the following conditions:**

1. Conditions and environments beyond the given specifications, or if product is used outdoors.
2. Installation on equipment in conjunction with atomic energy, railway, air navigation, vehicles, medical equipment, food and beverages, recreation equipment, emergency stop circuits, press applications, or safety equipment.
3. An application which has the possibility of having negative effects on people, property, or animals, requiring special safety analysis.



## Series AMJ

# Air Cleaning Equipment Precautions 1

Be sure to read before handling.

### Precautions on Design

Employ a safe design so that the following type of unexpected conditions will not occur.

#### Warning

- 1. A safe design should be employed which addresses the possibility of accidents following a drop in vacuum pressure due to clogging or trouble with the air supply, etc.**

If vacuum pressure drops and the adsorption force of the vacuum pad is lost, work pieces which are being carried will fall, causing a danger of human injury and damage to machinery. Safety measures should be employed, such as the installation of drop prevention guides, etc.

- 2. When operating with repetitive positive/negative pressure with a rapid repetition, the positive pressure side should be kept at 0.1MPa or less.**

Depending on conditions such as the pressure and the rate of repetition, the bowl may become hot.

### Selection

#### Warning

- 1. Confirm the specifications.**

The products contained in this catalog are designed only for use in compressed air systems (including vacuum).

Do not operate outside the specified range of pressure and temperature, etc., as this will cause damage or malfunction. (Refer to specifications.)

Contact SMC before using any fluid other than compressed air (including vacuum).

- 2. When selecting equipment, first adequately confirm the purpose for which it will be used, the required specifications and the operating conditions (pressure, flow rate, temperature, environment), etc. Then select from the latest catalog so that the specification range will not be exceeded. Contact SMC in advance with questions about any unclear points.**

- 3. This product cannot be used on board vehicles or vessels.**

This product cannot be used on board vehicles, vessels or other transportation devices, because vibration will cause damage. If this type of use is unavoidable, contact SMC in advance.

#### Caution

- 1. Do not allow flow greater than the rated flow rate.**

If the flow exceeds the rated flow rate even momentarily, this can cause condensation and oil to be sprayed into the downstream side or result in damage.

### Mounting

#### Warning

- 1. Instruction manual.**

The product should be mounted and operated after reading the manual carefully and having a good understanding of its contents. The manual should also be kept where it can be referred to whenever necessary.

- 2. Ensure sufficient maintenance space.**

Be sure to allow the space required for maintenance and inspections.

- 3. Be certain to keep threads tightened with the proper torque.**

- When screwing in piping, hold the side with the female thread and tighten with the recommended proper torque.

If the tightening torque is insufficient, this will cause looseness and faulty sealing. If the tightening torque is too high, this will cause damage to the threads, etc. Furthermore, if the female thread side is not held when tightening, a large force will be applied directly to the piping bracket and other parts, which may cause damage.

#### Recommended proper torque N·m (Kgf·cm)

Connection thread	M5	1/8	1/4	3/8	1/2	3/4	1
Torque	1.5 to 2 (15 to 20)	7 to 9 (70 to 90)	12 to 14 (120 to 140)	22 to 24 (220 to 240)	28 to 30 (280 to 300)	28 to 30 (280 to 300)	36 to 38 (360 to 380)

- Twisting moment or bending moment other than the dead weight of the equipment should not be applied.

To avoid damage, external piping should be supported separately from the product.

- Non-flexible piping is easily subject to the propagation of excessive moment load and vibration, etc. from steel and other similar pipes. Therefore, some type of flexible tubing should be used in between the equipment and the external piping to prevent this effect.

#### Caution

- 1. Confirm the mounting position.**

Since the mounting position is different for each piece of equipment, this point should be confirmed either in this catalog or in the instruction manual. If mounted in a tilted position, this can cause malfunction of drain discharging and damage to the equipment.

- 2. Ensure sufficient maintenance space.**

When installing and mounting, be sure to allow the space required for maintenance and inspections. Confirm the necessary maintenance space in the instruction manual for each piece of equipment.



## Series AMJ

# Air Cleaning Equipment Precautions 2

Be sure to read before handling.

### Piping

#### Caution

##### 1. Preparation before piping.

Before piping is connected, it should be thoroughly blown out with air (flushing) or washed to remove cutting chips, cutting oil and other debris from inside the pipe.

##### 2. Wrapping of pipe tape.

When screwing together pipes and fittings, etc., be certain that cutting chips from the pipe threads and sealing material do not get inside the piping.

Further, when pipe tape is used, leave 1.5 to 2 thread ridges exposed at the end of the pipe.

##### 3. Implement measures to prevent condensate from collecting inside piping.

For example, drains should be installed in the lower sections of piping that rises, or piping should be designed with a slight taper provided along the direction of flow so that drainage will not accumulate.

##### 4. Confirm IN and OUT ports.

When piping is being installed, take care to prevent incorrect connection of the water and air sides, or the IN and OUT ports.

### Air Supply

#### Warning

##### 1. Types of fluid.

This product is designed for use with compressed air (including vacuum). Contact SMC in case a different fluid is to be used.

Contact SMC regarding the types of fluids which can be used in products designed for use with general purpose fluids.

##### 2. Do not use compressed air which contains chemicals, organic solvents or corrosive gases.

Do not use compressed air containing chemicals, organic solvents, salt or corrosive gases, as this can cause damage and malfunction, etc.

##### 3. Operating pressure range.

The operating pressure range is determined by the equipment being used. Operation beyond this range can cause malfunction or failure.

### Operating Environment

#### Warning

##### 1. Do not use in the following environments, as this can cause failure.

1. Locations with an atmosphere of corrosive gases, organic solvents or chemical solutions, and locations where there may be contact with the same.
2. Locations where there is contact with sea spray, water or steam.
3. Locations which receive direct sunlight. (Sunlight should be blocked to prevent deterioration of resin from ultra violet rays and over heating, etc.)
4. Locations near heat sources with poor ventilation. (Heat sources should be blocked off, because radiated heat may cause damage due to softening of materials.)

### Operating Environment

#### Warning

5. Locations with impacts or vibration. (Confirm specifications.)
6. Locations with high moisture and dust. (Contact SMC in advance.)

##### 2. Adhere to the fluid and ambient temperature ranges.

The fluid and ambient temperatures are determined by the equipment being used. Operation beyond this range can cause damage, failure or malfunction, etc.

### Maintenance

#### Warning

##### 1. Maintenance should be performed in accordance with the procedures in the instruction manual.

If handled improperly, this can cause damage or malfunction in equipment and devices, etc.

##### 2. Maintenance operations.

Since compressed air can be dangerous if handled improperly, element replacement and other maintenance, etc. should be performed by personnel having sufficient knowledge and experience pertaining to pneumatic equipment, while also adhering to the product specifications.

##### 3. Drain flushing.

Drains should be flushed periodically. (Refer to specifications.)

##### 4. Pre-maintenance checks.

When the product is to be demounted, first the electric power supply should be shut off and supply pressure should also be stopped. Then compressed air in the piping should be exhausted, and an atmospheric release condition should be confirmed before proceeding.

##### 5. Post maintenance checks.

After mounting, repair or renovation, compressed air and electric power, etc. can be reconnected, and then suitable function and leak inspections should be performed. If an audible leak is detected or equipment does not operate properly, operation should be stopped and correct mounting should be confirmed.

##### 6. When performing inspections, the compressed air pressure should be set to zero.

When the compressed air side is to be disassembled for inspections or filter element replacement, etc., first confirm that the pressure is at zero before proceeding.

##### 7. Disassembly and modification is prohibited.

The main unit should not be disassembled or modified, etc.

#### Caution

##### 1. Do not step on or place heavy objects on the unit.

The equipment may be deformed or damaged, and if balance is lost, a fall may cause injury.

##### 2. Discharge drainage regularly.

If drainage accumulates in equipment, in piping or other areas, this can cause malfunction of the equipment or unexpected trouble due to splash over into the downstream side, etc. Therefore, the amount of drainage should be checked every day.



# Series AMJ Specific Product Precautions 1

Be sure to read before handling.

Refer to pages 4 through 6 for safety precautions and air cleaning equipment precautions.

## Mounting

### Caution

1. Air piping should be thoroughly flushed before mounting.
2. When piping and fittings, etc. are being screwed together, take care that cutting chips from the pipe threads, sealing material and other debris do not get inside the piping.  
Further, when pipe tape is used, leave 1.5 to 2 thread ridges exposed at the end of the pipe.
3. The unit should be mounted vertically.

## Atmosphere

### Warning

1. Since the case material is polycarbonate, avoid using chemicals such as thinner, carbon tetrachloride, chloroform, aniline, cyclohexane, trichloroethylene, sulfuric acid, lactic acid or water-miscible cutting fluid (alkaline), etc. Operation of the product in an atmosphere containing any of these chemicals should also be avoided.  
A neutral detergent may be used for cleaning the case.
2. Avoid use in direct sunlight.

## Maintenance

### Caution

1. The element should be replaced after 2 years of use, or before the pressure drops to 0.02MPa {0.2kgf/cm<sup>2</sup>}.  
The spacer and O-ring should also be replaced at the same time that the element is replaced.  
Sometimes when the case is removed for a purpose other than replacing the element, the spacer may stick to the case and come off. In this case however, it may be returned to its installed position and used again.
2. Drainage should be discharged by the time it reaches the upper limit.  
Furthermore, when drainage is to be discharged or the element replaced, first confirm that all equipment, etc. is stopped, and return the case interior to atmospheric pressure before proceeding.