

Material

Stahl verzinkt (DIN 2353)

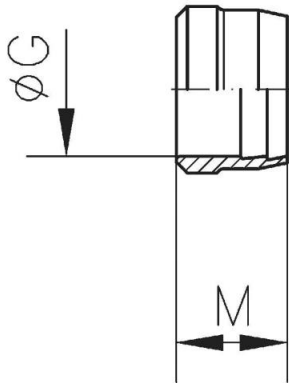

SR10SLST

**Schneidring, sehr leichte Ausführung**

Artikel Nr.	Typen Nr.	Rohr- Außen-Ø mm	Ø F1	Ø G	A mm	M mm	CH mm	PN bar
159348	SR10SLST	10	14x1	10	12,5	7,0	17	100
159349	SR12SLST	12	16x1	12	13,0	7,5	19	100

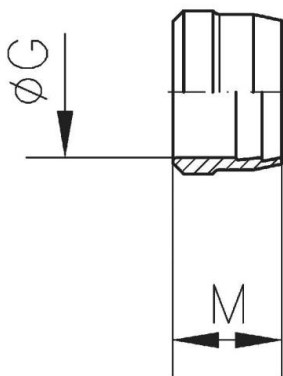

SR28LST

**Schneidring, leichte Ausführung**

Artikel Nr.	Typen Nr.	Rohr- Außen-Ø mm	Ø F1	Ø G	A mm	M mm	CH mm	PN bar
159350	SR28LST	28	36x2	28	21	11	41	160

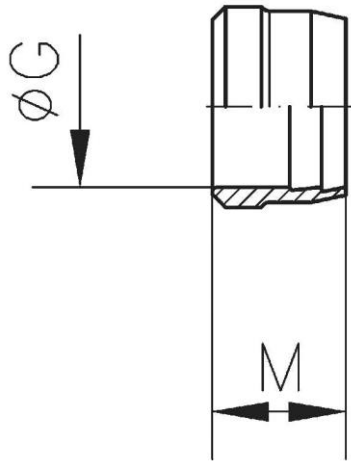

SR10SST

**Schneidring, schwere Ausführung**

Artikel Nr.	Typen Nr.	Rohr- Außen-Ø mm	Ø F1	Ø G	A mm	M mm	CH mm	PN bar
159351	SR6SST	6	14x1,5	6	16,5	9,5	17	630
159352	SR8SST	8	16x1,5	8	16,5	9,5	19	630
159353	SR10SST	10	18x1,5	10	17,5	10,0	22	630
159354	SR12SST	12	20x1,5	12	17,5	10,0	24	630
159355	SR14SST	14	22x1,5	14	20,5	10,0	27	630
159356	SR16SST	16	24x1,5	16	20,5	10,5	30	400
159357	SR20SST	20	30x2,0	20	24,0	13,0	36	400
159358	SR25SST	25	36x2,0	25	27,0	13,0	46	400

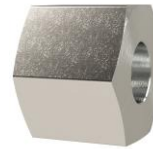
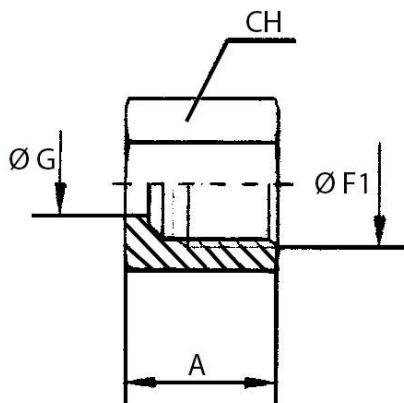

UE10SLST

### Überwurfmutter, sehr leichte Ausführung

Artikel Nr.	Typen Nr.	Rohr- Außen-Ø mm	Gewinde Ø F1	Ø G	A mm	M mm	CH mm	PN bar
159359	UE10SLST	10	M14x1	10	12,5	7,0	17	100
159360	UE12SLST	12	M16x1	12	13,0	7,5	19	100

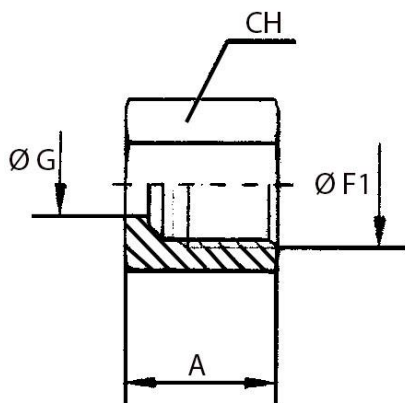

UE28LST

### Überwurfmutter, leichte Ausführung

Artikel Nr.	Typen Nr.	Rohr- Außen-Ø mm	Gewinde Ø F1	Ø G	A mm	M mm	CH mm	PN bar
159361	UE28LST	28	M36x2	28	21	11	41	160

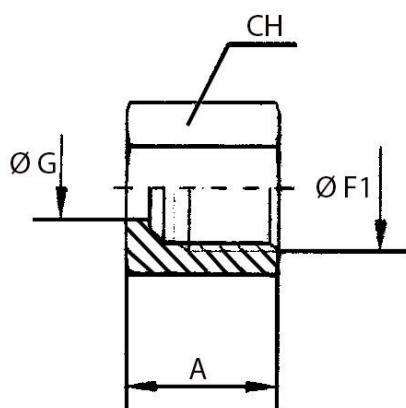

UE6SST

### Überwurfmutter, schwere Ausführung

Artikel Nr.	Typen Nr.	Rohr- Außen-Ø mm	Gewinde Ø F1	Ø G	A mm	M mm	CH mm	PN bar
159362	UE6SST	6	M14x1,5	6	16,5	9,5	17	630
159363	UE8SST	8	M16x1,5	8	16,5	9,5	19	630
159363	UE10SST	10	M18x1,5	10	17,5	10,0	22	630
159365	UE12SST	12	M20x1,5	12	17,5	10,0	24	630
159366	UE14SST	14	M22x1,5	14	20,5	10,0	27	630
159367	UE16SST	16	M24x1,5	16	20,5	10,5	30	400
159368	UE20SST	20	M30x2,0	20	24,0	13,0	36	400
159369	UE25SST	25	M36x2,0	25	27,0	13,0	46	400

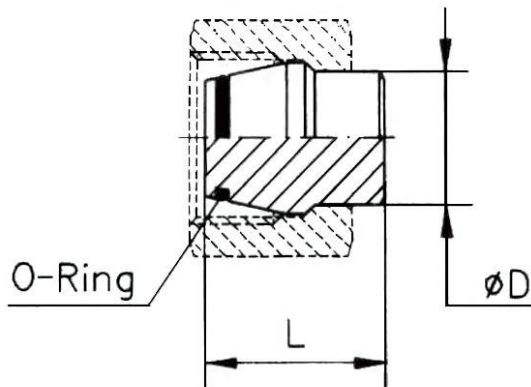

VST6LST

### Verschlussstopfen, leichte Ausführung

Artikel Nr.	Typen Nr.	Rohr- Außen-Ø mm	L mm	O-Ring	PN bar
159370	VST6LST	6	18,5	4,0x1,5	315
159371	VST8LST	8	18,5	6,0x1,5	315
159372	VST10LST	10	20,0	7,5x1,5	315
159373	VST12LST	12	20,5	9,0x1,5	315
159374	VST15LST	15	20,5	12,0x2,0	315
159375	VST18LST	18	22,5	15,0x2,0	315
159376	VST22LST	22	25,0	20,0x2,0	160
159377	VST28LST	28	25,5	26,0x2,0	160

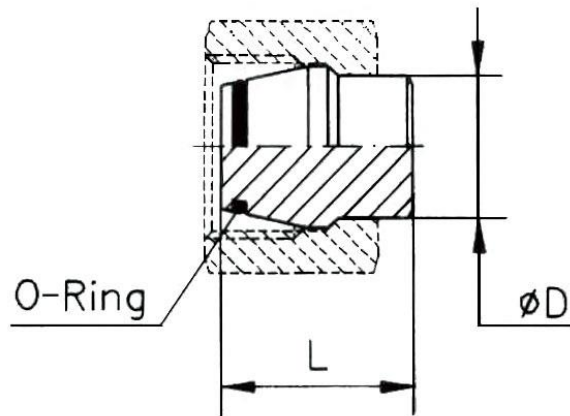

VST6SST

**Verschlussstopfen, schwere Ausführung**

Artikel Nr.	Typen Nr.	Rohr- Außen- $\varnothing$ mm	L mm	O-Ring	PN bar
159378	VST6SST	6	18,5	4,0x1,5	630
159379	VST8SST	8	18,5	6,0x1,5	630
159380	VST10SST	10	20,0	7,5x1,5	630
159381	VST12SST	12	20,5	9,0x1,5	630
159382	VST14SST	14	22,5	10,0x2,0	630
159383	VST16SST	16	23,5	12,0x2,0	400
159384	VST20SST	20	28,5	16,3x2,4	400
159385	VST25SST	25	29,0	20,3x2,4	400

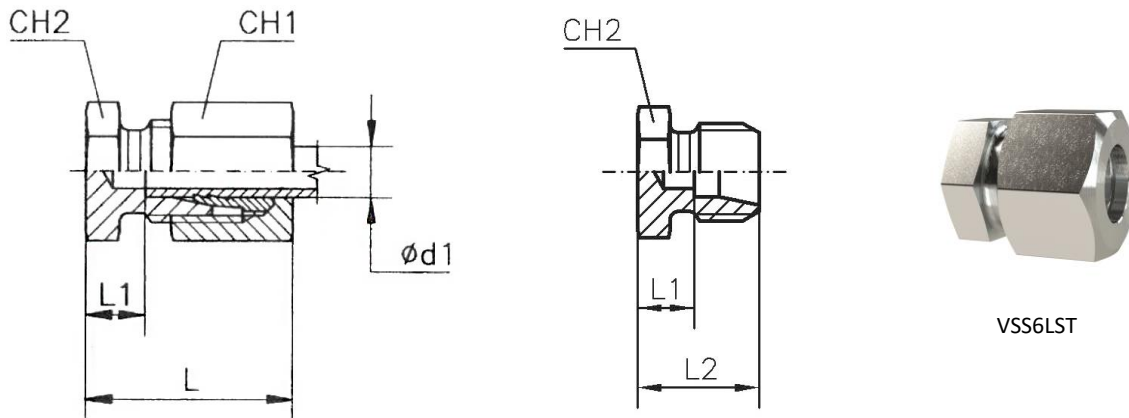

### Verschlusschraube, leichte Ausführung

Artikel Nr.	Typen Nr.	Rohr- Außen-Ø mm	L mm	L1 mm	L2 mm	CH1 mm	CH2 mm	PN bar
159386	VSS6LST	6	22	7,0	14	14	12	315
159387	VSS8LST	8	23	8,0	15	17	14	315
159388	VSS10LST	10	24	9,0	16	19	17	315
159389	VSS12LST	12	25	10,0	17	22	19	315
159390	VSS15LST	15	26	11,0	18	27	24	315
159391	VSS18LST	18	28	11,5	19	32	27	315
159392	VSS22LST	22	30	13,5	21	36	32	160
159393	VSS28LST	28	31	14,5	22	41	41	160

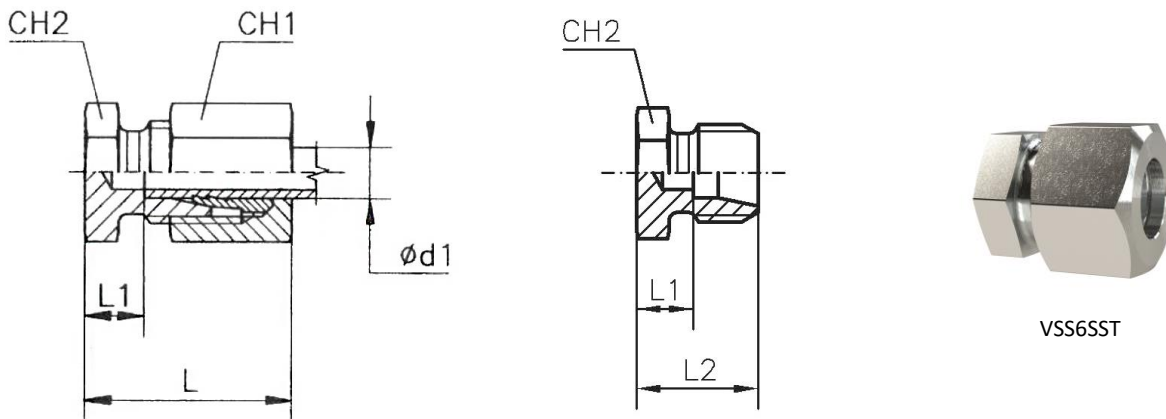
**Verschlusschraube, schwere Ausführung**

Artikel Nr.	Typen Nr.	Rohr- Außen- $\varnothing$ mm	L mm	L1 mm	L2 mm	CH1 mm	CH2 mm	PN bar
159394	VSS6SST	6	26	11,0	18	17	14	360
159395	VSS8SST	8	28	13,0	20	19	17	360
159396	VSS10SST	10	29	12,5	20	22	19	360
159397	VSS12SST	12	31	14,5	22	24	22	360
159398	VSS14SST	14	34	16,0	24	27	24	360
159399	VSS16SST	16	34	15,5	24	30	27	400
159400	VSS20SST	20	39	17,5	28	36	32	400
159401	VSS25SST	25	44	20,0	32	46	41	400