

"Schutzvermerk nach DIN 34 beachten"

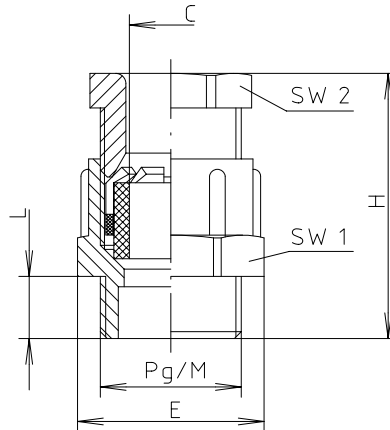

Modell	Pg	Außen- $\phi$		C	L	SW1	SW2	H	E
		Pg							
POZ 7	Pg 7	12,5		4-6	8	15	13	29	16,5
POZ 9	Pg 9	15,2		6-8	8	19	16	32	21
POZ 11	Pg 11	18,6		8-10	8	22	19	32,5	25
POZ 13	Pg 13,5	20,4		10-12	9	24	21	38	27
POZ 16	Pg 16	22,5		12-14	10	27	23	39	29,5
POZ 21	Pg 21	28,3		14-18	11	32	30	44,5	35,5
POZ 29	Pg 29	37		18-24	11	42	40	47	45,5

Modell	M	C	L	SW1	SW2	H	E
MPOZ 12-1	M 12x1,5	4-6	8	15	13	39	16,5
MPOZ 12-2	M 12x1,5	6-8	11	19	16	46	20,5
MPOZ 16	M 16x1,5	6-8	11	19	16	46	20,5
MPOZ 20-1	M 20x1,5	8-10	11	22	19	48,5	24,5
MPOZ 20-2	M 20x1,5	10-12	11	24	21	48,5	26
MPOZ 20-3	M 20x1,5	12-14	11	27	23	52	29,5
MPOZ 25-2	M 25x1,5	14-18	11	32	30	56	35,5
MPOZ 32	M 32x1,5	18-24	11	42	40	60,5	45,5

Maßstab : (1:1 symbolisch)

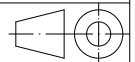

Zchn.Nr: 4K 5350.004.01

Artikel: Kabelverschraubung  
(M)POZ . . .  
Katalogzeichnung



DISK : 2 502 623  
Datum: 21.10.2005 HR

Ä.Nr: Datum: