



# BURST FIRED AC ENERGY REGULATOR 110-230V AC    16A

**ZVS  
16DV  
X10249**

### INTRODUCTION

The ZVS 16DV is a dual voltage, 16A, enclosed, compact energy regulator. It provides manual proportional power control to resistive loads by using variable bursts of energy. The burst firing circuit provides trigger pulses coincident with the mains polarity crossover, ensuring complete sine wave cycles are passed through to the resistive load. This prevents fast changes in load current and inhibits radio frequency interference (RFI), which is normally associated with switches, relays and phase angle fired triacs or similar devices. The output is in block bursts, with a full 0 to 100% range.

### APPLICATIONS

Virtually all resistive heating loads including ovens, furnaces, hot plates, extruders, moulders, space heating, boilers,

### FEATURES

- Input voltage range suitable for 110V to 230V ac
- Load rating range - resistive, from 0.1 to 3.7kW @ 230V and 0.1 to 1.8kW @ 110V ac
- High surge 26A power device
- No remote filter requirements - Zero Voltage Switching control
- Wire protective screw fixing terminal block connections

RoHS Compliant



### INSTALLATION

#### DIMENSIONS AND CONNECTIONS

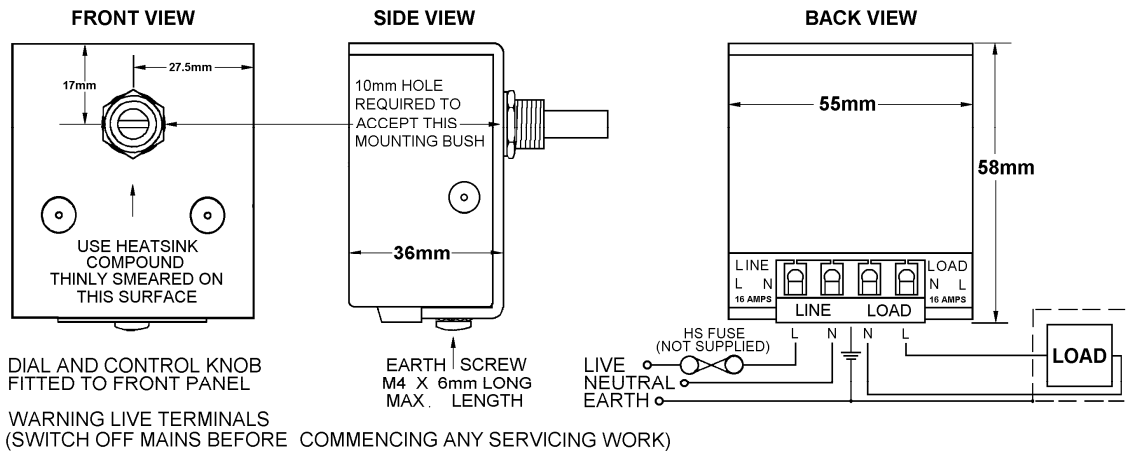

## INSTALLATION

## COOLING REQUIREMENTS

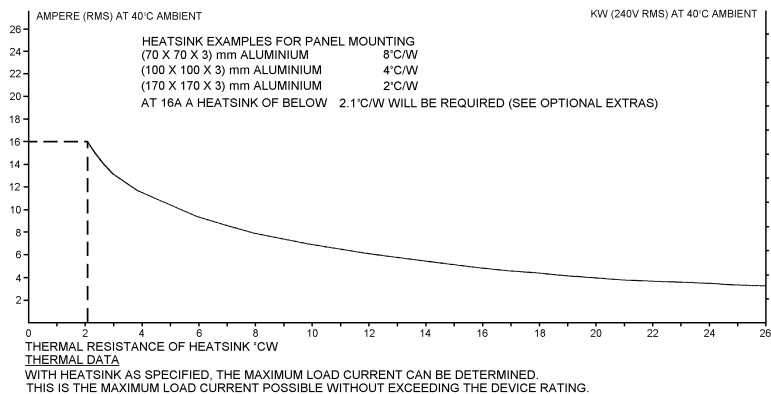

## SPECIFICATIONS

Maximum rms on-state current	16A	I <sup>2</sup> t for fusing	128 A <sup>2</sup> s
Peak one cycle surge current	200A	Weight (approx)	105g
Maximum supply voltage +/-10% @ 50/60Hz	230V	Maximum CSA cable entry	2.5mm <sup>2</sup>
Minimum supply voltage +/-10% @ 50/60Hz	110V	<i>further dimensions</i>	
Maximum peak repetitive voltage	600V	Shaft diameter (1/4 inch)	6.3mm
Maximum Power consumption	6W	Shaft projection from bush	13mm
Operating and storage temperature range	0 to +85°C	Bush length	7mm
Isolation voltage	2.5kV rms	Fixing hole diameter	10mm

## FUSING

It is recommended to use semiconductor (fast-acting) type fuses or circuit breakers (semiconductor - MCB) for unit protection. On initial use some loads may need an increased factor of safety for unit and/or device protection, see SRA datasheet for further information.

## CE MARKING

This product family carries a CE marking. For information see recommendation section and contact our sales desk (see Declaration of Conformity).

## RECOMMENDATION

Other documents available on request, which may be appropriate for your applications.

CODE	IDENTITY	DESCRIPTION
X10229	RFI	Filtering recommendation - addressing EMC Directive
X10213	ITA	Interaction, uses for phase angle and for burst fire control.
X10255	SRA	Safety requirements - addressing the Low Voltage Directive (LVD) including: thermal data/cooling, live parts warning, earth requirements and fusing recommendations.
P01.1	COS	UAL conditions of sale.

**NOTE:** It is recommended that installation and maintenance of this equipment should be done with reference to the current edition of the I.E.T. (formally I.E.E.) regulations (BS7671) by suitably qualified/trained personnel. The regulations contain important requirements regarding installation and safety of electrical equipment. Specific installers should refer to local and national regulations.

**ORDER CODE:** State product description **ZVS 16DV**

OPTIONAL EXTRAS: Standard knob; ZVS dial, heatsink compound

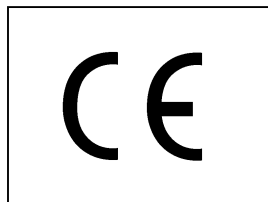

**UNITED AUTOMATION LIMITED**  
 Southport Business Park  
 Wight Moss Way  
 Southport, PR8 4HQ  
 ENGLAND

Tel: 0044 (0) 1704 – 516500  
 Fax: 0044 (0) 1704 – 516501  
 enquiries@united-automation.com  
 www.united-automation.com

Page No. 2 of 2      Issue 3      Date 31/07/12

