

High Performance dual-stage IEC C14 inlet filter with earth line choke



- Rated currents up to 15 A
- Excellent performance/size ratio
- Earth line choke Version
- IEC C14 inlet acc. IEC 60320-1
- Medical versions (B type) acc. to IEC/EN 60601-1
- Snap-in and rear mount versions (S and M type)



Performance indicators

Attenuation performance



Rated current [A]



Approvals



The FN9255 E IEC inlet filter incorporates a dual stage filter with Earth line choke into an IEC inlet that offers excellent filter attenuation in a compact housing. Using an IEC inlet, at the point of entry offers an optimized position and practical solution for integrating an EMC filter into any system. A wide selection of current ratings, output connections and mounting possibilities are available. The E Version of this family complies to medical application and safety requirements, with enhanced performance without added leakage current.

Features and benefits

- Exceptional attenuation performance from 150kHz to 300MHz due to dual-stage design
- High saturation resistance and excellent thermal behavior
- Medical versions (B type) comply with the requirements of IEC/EN 60601-1 for creepage and clearance, leakage current and high potential testing
- Suitable for IEC/EN 55014 tests up to 300MHz
- Rear and Front flange or snap-in mounting options
- Earth line choke Version, for standard version see FN 9255
- All versions according IEC/EN 62368-1

Technical specifications

Maximum continuous operating voltage	250 VAC, 50/60 Hz
Rated currents	2 to 15 A @ 40°C max.
Operating frequency	DC to 400 Hz
Approvals by rated current	ENEC and CQC: 2 to 10 A UL: 2 to 15A
High potential test voltage	P → PE 2500 VAC for 2 sec P → N 760 VAC for 2 sec
Protection category	IP 40 according to IEC 60529
Temperature range (operation and storage)	-25°C to +85°C (25/85/21)
Design corresponding to	UL 60939-3, IEC/EN 60939-3
Flammability according to	UL 94 V-0

Typical applications

- Medical devices (MDD)
- Household and similar products as per IEC/EN55014
- Test and measurement equipment
- In-vitro diagnostic medical devices (IVDD)
- Portable electrical and electronic equipment
- Small to medium-sized machines and household equipment
- Single-phase power supplies, switch-mode power supplies (SMPS)

Typical electrical schematic

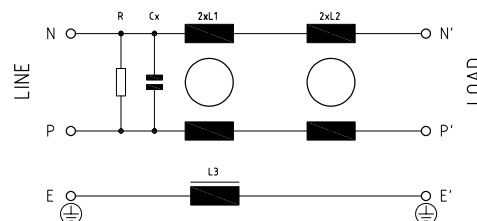

Filter selection table

Filter	Rated current @ 40°C [A]	Leakage current* @ 250 VAC/50 Hz (@ 120 VAC/60 Hz) [mA]	Inductance			Capacitance Cx [μF]	Resistance R [kΩ]	Output connections		[g]
			L1 [mH]	L2 [μH]	L3 [mH]			[Diagram]	** [Diagram]	
FN 9255 ExB-2-06	2	-	4.8	18	0.4	0.1	1000	-06	-07	66
FN 9255 ExB-4-06	4	-	2.1	18	0.4	0.1	1000	-06	-07	66
FN 9255 ExB-6-06	6	-	0.9	18	0.4	0.1	1000	-06	-07	66
FN 9255 ExB-10-06	10	-	0.2	18	0.4	0.1	1000	-06	-07	68
FN 9255 ExB-15-06	15	-	0.13	8	0.1	0.1	1000	-06	-07	68

Test conditions: 25°C±2°C; Measuring frequency for Inductance: 1 kHz; 50 mV;

Tolerances: Inductance: +50%, -30%; Capacitance: ±25%; Resistor: ±15%; For mechanical tolerances refer to mechanical data section.

* Maximum leakage under normal operating conditions (acc. to IEC60939-3). Note: if the neutral line is interrupted, worst case leakage could reach twice this level.

** Standard length is 100 mm

Typical filter attenuation

Per CISPR 17; symmetrical 50 Ω/50 Ω - Differential Mode (DM); asymmetrical 50 Ω/50 Ω - Common Mode (CM)

2 A type

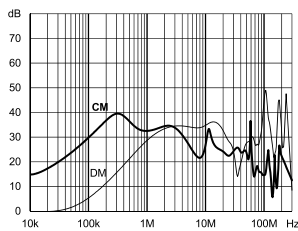

4 A type

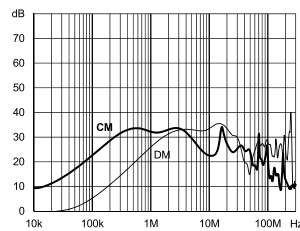

6 A type

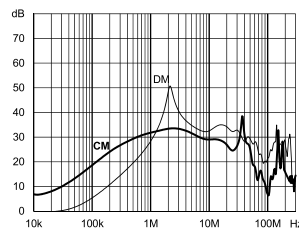

10 A type

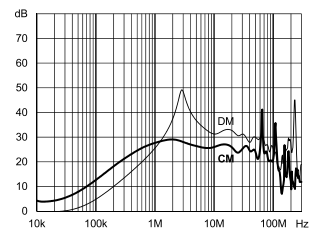

15 A type

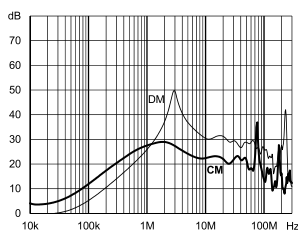

Product selector

FN 9255 E x B -yy-...-(zz)

- Blank: Snap-in range for S version only
- Blank: Snap-in range 0.7 to 1.5 mm
- 20: Snap-in range 1.5 to 2.2 mm
- 06: Faston 6.3 x 0.8 mm (spade/soldering)
- 07: Wire leads
- 2 to 15: Rated current
- Blank: Standard housing with mounting flanges (front mount)
- M: Standard housing with mounting flanges (rear mount)
- S: Snap-in version, snapper on vertical side

For example:

FN 9255 EB-15-06, 15A Version with fast-on terminals

FN 9255 ESB-10-06, 10A Version with fast-on terminals, snap-in version

FN 9255 EMB-2-07, 2A Version with wire leads, rear mount version

Mechanical data

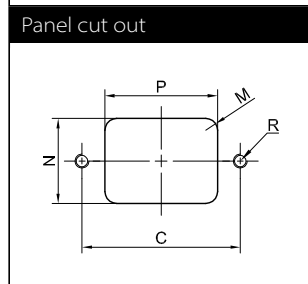
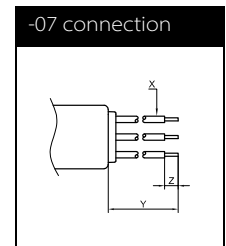
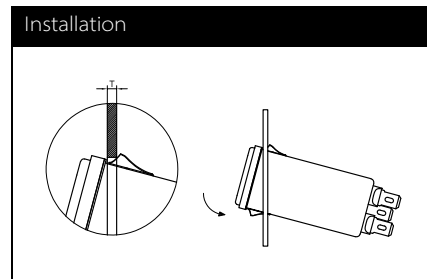
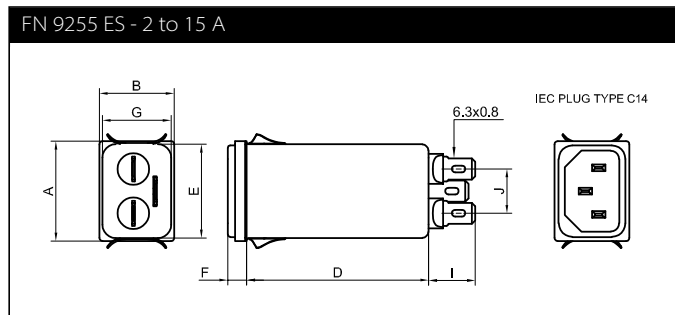
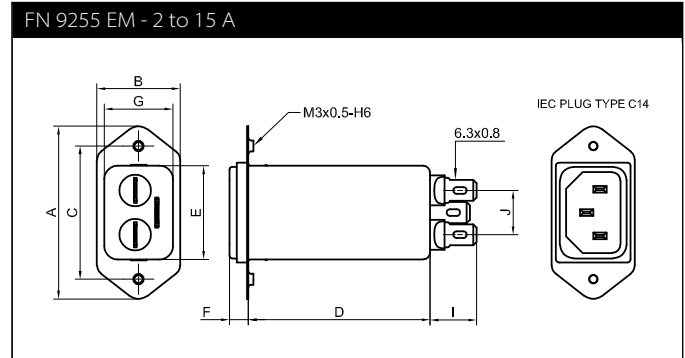
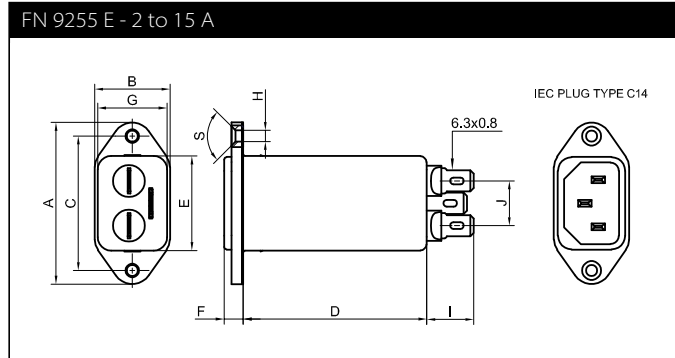

Dimensions

	FN 9255 EB	FN9255 EMB	FN9255 ESB
A	48	51.85	29.9
B	22.4	25	22.4
C	40 ±0.2	40 ±0.2	
D	76.2	76.2	76.2
E	28.1 ±0.3	28.1 ±0.3	28.1 ±0.3
F	5.8 ±0.2	5.8 ±0.2	5.8 ±0.2
G	20.6 ±0.3	20.6 ±0.3	20.6 ±0.3
H	Ø3.3	M3	
I	14	14	14
J	13.3	13.3	13.3
M	R ≤ 3	R ≤ 1	R ≤ 1.5
N	21.5 +0.5/-0	22.9 +0.2/-0	21.5 +0.5/-0
P	28.5 +0.5/-0	30.4 +0.2/-0	29.4
R*	M3	Ø3.4	
S / T	S: 90°		T: 0.7 to 1.5
X / Y	AWG 18 / 100 mm (>6A: AWG 16)	AWG 18 / 100 mm (>6A: AWG 16)	AWG 18 / 100 mm (>6A: AWG 16)
Z	6	6	

* Recommended torque for M3 (90° countersunk flat head) is 0.5 Nm

All dimensions in mm; 1 inch = 25.4 mm

For values without dedicated tolerances ISO 2768-m/EN 22768-m applies.

Please visit www.schaffner.com to find more details on connectors.