



Part no.: 50106413
TFM 05 1510.210
Transponder



Figure can vary

Contents

- Technical data
- Dimensioned drawings
- Notes
- Accessories

Part no.: 50106413 – TFM 05 1510.210 – Transponder

Technical data

Basic data

| | |
|-------------------|-----------|
| Series | TFM |
| Suitable for | RFM |
| Chip | I-CodeSLI |
| Working frequency | 13.56 MHz |

Electrical data

Performance data

| | |
|-------------------|-------------|
| Memory access | Read/Write |
| Memory size | 112 B |
| Memory block | 28 Piece(s) |
| Memory block size | 4 B |
| Storage time | 50 ms |

Certifications

| | |
|-------------------|-----------|
| Standards applied | ISO 15693 |
|-------------------|-----------|

Mechanical data

| | |
|------------------|-----------------|
| Design | Disc |
| Thickness | 2.5 mm |
| Outer diameter | 50 mm |
| Inner diameter | 5 mm |
| Housing material | Plastic , PA 66 |
| Net weight | 4 g |

Environmental data

| | |
|--------------------------------|----------------|
| Ambient temperature, operation | -25 ... 85 °C |
| Ambient temperature, storage | -40 ... 140 °C |

Certifications

| | |
|----------------------|-------|
| Degree of protection | IP 68 |
|----------------------|-------|

Classification

| | |
|-----------------------|----------|
| Customs tariff number | 85235200 |
| eCl@ss 8.0 | 27289290 |
| eCl@ss 9.0 | 27280402 |
| ETIM 5.0 | EC002996 |
| ETIM 6.0 | EC002996 |

Dimensioned drawings

All dimensions in millimeters

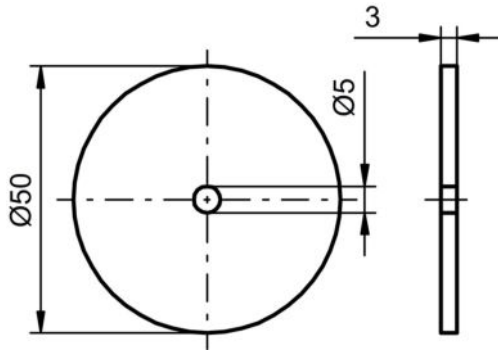

Notes

Observe intended use!

- This product is not a safety sensor and is not intended as personnel protection.
- The product may only be put into operation by competent persons.
- Only use the product in accordance with its intended use.

- Under certain circumstances, metal in the reading field reduces the operating range considerably.

Accessories

Mounting technology - Other

| | Part no. | Designation | Article | Description |
|---|----------|--------------|---------|--|
|  | 50107103 | Spacer 50 HT | Spacer | Design, housing: Hollow cylinder Inner diameter: 5 mm Housing material: Plastic, PA 66 |

Note

A list with all available accessories can be found on the Leuze electronic website in the Download tab of the article detailed page.