

# BAU

BUILDING BATIMENT



**EKU PORTA**<sup>®</sup>  
Holz | Wood | Bois

## Schiebetechnik für Holztüren

Sliding technique for wooden doors

Technique de coulisse pour  
portes en bois

**EKU**   
Sliding Solutions



60/100 HM

60/100 HM

EKU-PORTA 60/100 HMD





















EKU-PORTA 60/100 HM









60/100 HMD

60/100 HMD



|   |   |   |              |
|---|---|---|--------------|
|    | <b>EKU-PORTA 45 H</b>   |    | <b>6/7</b>   |
|    | <b>EKU-PORTA 60/100 H</b>   |    | <b>8/9</b>   |
|    | <b>EKU-PORTA 60/100 HC</b>  |    | <b>10/11</b> |
|    | <b>EKU-PORTA 60/100 H/HC Synchro</b>  |    | <b>12/13</b> |
|    | <b>EKU-PORTA 60/100 HM</b>  |    | <b>14/15</b> |
|    | <b>EKU-PORTA 60/100 HMD</b>   |    | <b>16/17</b> |
|   | <b>EKU-PORTA 100</b><br>4-Punkt Führung/4 point guide system/guidage à 4 points |    | <b>20/21</b> |
|  | <b>EKU-PORTA 60/100</b><br>Stapelung/Stacking/Empilage                          |  | <b>22/23</b> |
|  | <b>EKU-PORTA 300 H</b>  |  | <b>24/25</b> |
|  | <b>EKU-PORTA 600 H</b>  |  | <b>26/27</b> |

|  |   |           |
|--|---|-----------|
| <b>Sonderzubehör EKU-PORTA 45/60/100</b>   |    | <b>18</b> |
| Special accessories<br>Accessoires spéciaux  |   |           |
| <b>Einzelteile EKU-PORTA 45</b>  |    | <b>19</b> |
| Components<br>Pièces détachées   |   |           |
| <b>Einzelteile EKU-PORTA 60/100</b>  |    | <b>20</b> |
| Components<br>Pièces détachées   |   |           |
| <b>Sonderzubehör EKU-PORTA 300</b>   |    | <b>28</b> |
| Special accessories<br>Accessoires spéciaux  |   |           |
| <b>Einzelteile EKU-PORTA 300</b>   |    | <b>28</b> |
| Components<br>Pièces détachées   |   |           |
| <b>Einzelteile EKU-PORTA 600</b>   |    | <b>29</b> |
| Components<br>Pièces détachées   |   |           |
| <b>EKU-Qualität</b>  |    | <b>30</b> |
| EKU-Quality <br>EKU-Qualité |   |           |
| <b>Türgewichte</b>   |  | <b>31</b> |
| Door weights<br>Poids de portes  |   |           |
| <b>Technische Daten</b>  |  | <b>31</b> |
| Technical data<br>Caractéristiques techniques  |   |           |

System  
Système

Tragkraft pro Türe  
Carrying capacity  
per door  
Capacité de charge par porte



**100 HMD**

Modell  
Model  
Modèle



45/60/100 H



60/100 H



60/100 HC



60/100 HC



60/100 HC

EKU-PORTA 60/100 H  
EKU-PORTA 60/100 HC



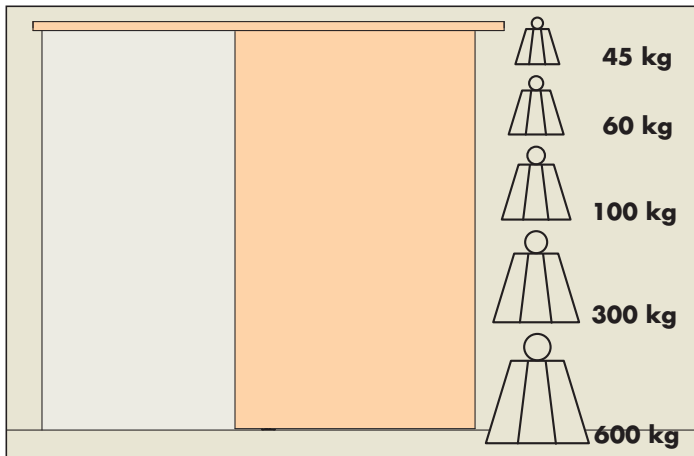

**5 Gewichtsklassen – 1 Beschlagssystem**

5 weight classes – 1 hardware system

5 catégories de poids – 1 système de ferrures

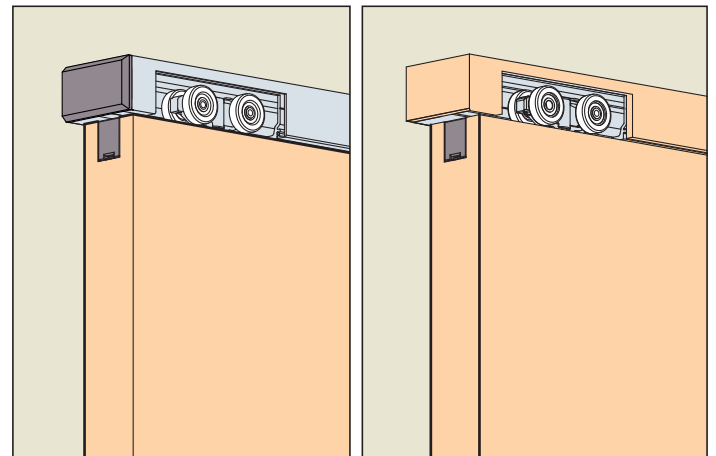

**Design-Laufschiene 31 mm hoch für Wandmontage mit Alu- oder Holz-Blende**

Design running track 31 mm high for wall mounting with aluminium or wooden panel

Rail de roulement design 31 mm haut pour montage mural avec cache bois ou alu

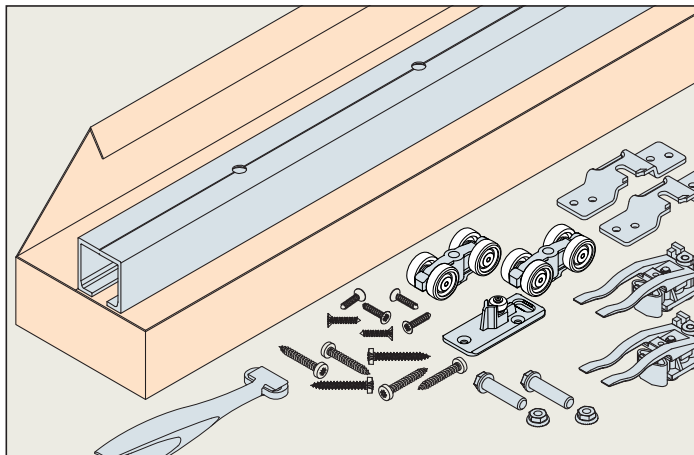

**Bestellung einfach und wirtschaftlich als Set**

Can be ordered as a set – simple and economical

Commande en kit simple et économique

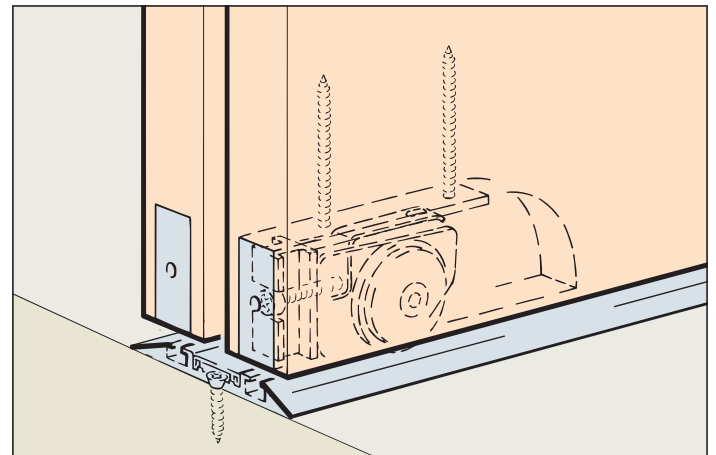

**Attraktives Zubehör – Synchro, Stapelung und 4-Punkt Führung**

Attractive accessories – Synchro, stacking system and 4-point guidance

Accessoire attractif – Synchro, parçage des portes en parallèle et guidage 4 points

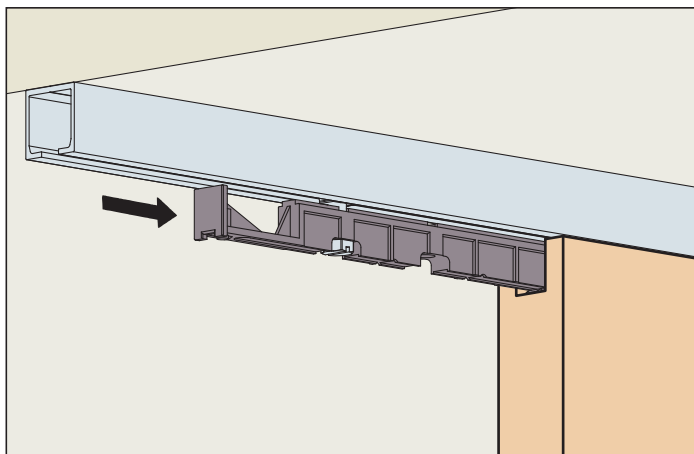

**Einfache und schnelle Türmontage ohne Werkzeug**

Door installation is quick and easy, without tools

Montage de porte simple et rapide sans outillage

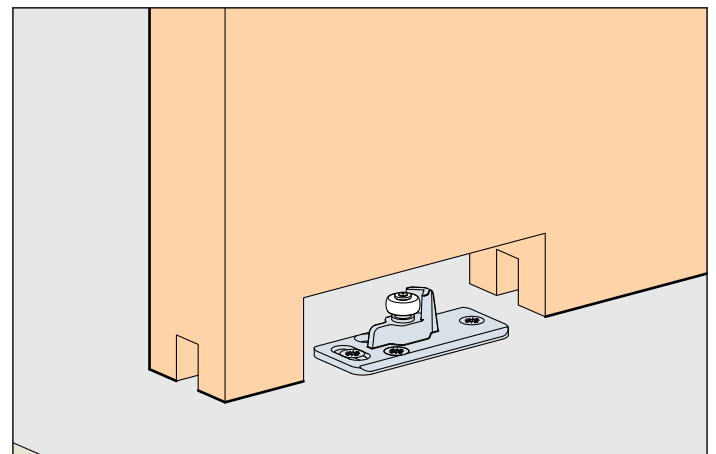

**Leichter und leiser Lauf – Laufwerke mit Präzisionskugellager – Bodenführung mit Rolle**

Gentle, quiet operation – running gear with precision ball bearings – floor guide with roller

Course légère et silencieuse – Chariots avec roulement à billes de précision – Guidage au sol avec galet



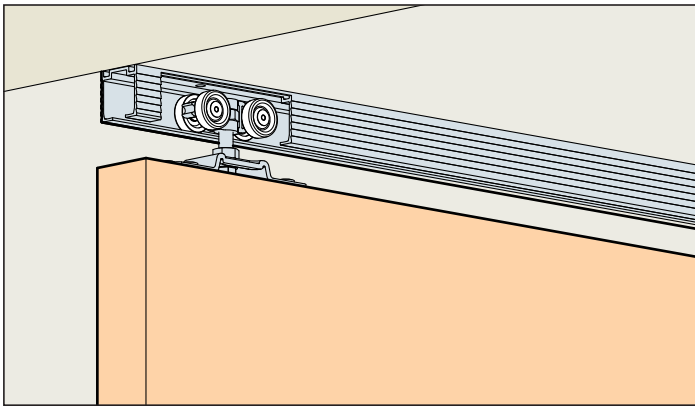

**System: Laufschiene für Decken- oder Wandmontage, für 1 Holztüre bis 45 kg.**

System: Running track for ceiling or wall mounting, for 1 wooden door up to 45 kg.

Système: Rail de roulement pour montage au plafond ou mural, pour 1 porte en bois jusqu'à 45 kg.

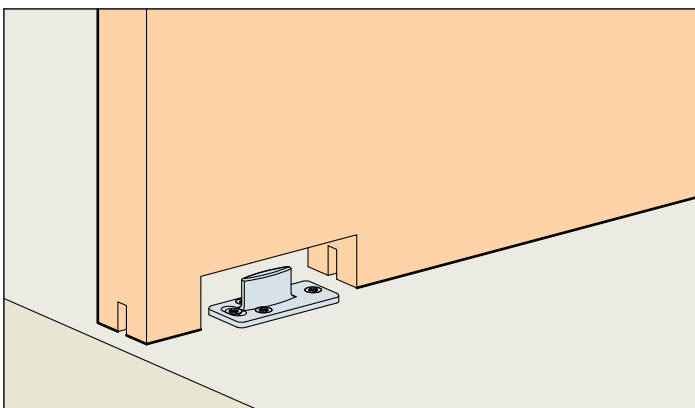



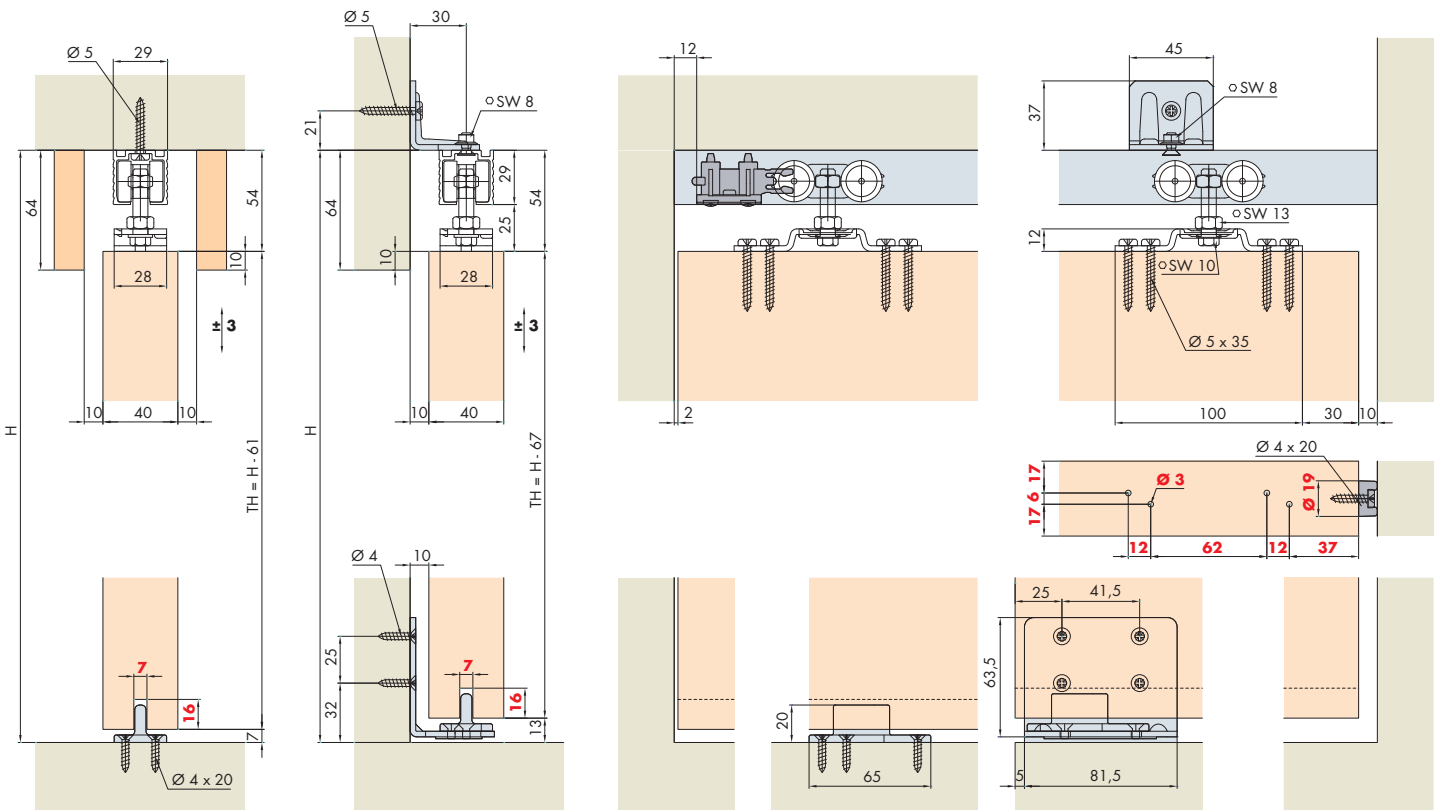

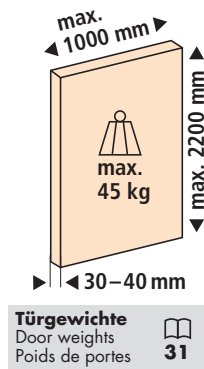





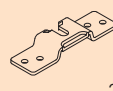

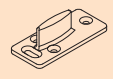
**Einbaubeispiele / Mounting examples / Exemples de montage**



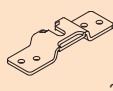

**Garnituren / Sets / Garnitures**

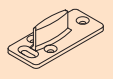
|  |   |   |
|--|---|---|
| <b>1</b> Türe<br>Door<br>Porte   | <b>No. 057.3045.071</b>   |   |
|  2x |  2x  |  2x |
|  1x |  1x |   |
|  1x |    |   |

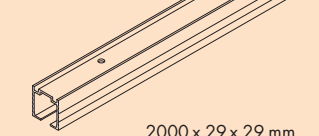
|  |  |  |
|--|--|--|
| <b>1</b> Türe<br>Door<br>Porte   | <b>No. 057.3144.071</b>  |  |
|  2x                   |  2x |  2x |
|  1x                   |  1x |  |
|  1x                   |     |  |
| <br>2000 x 29 x 29 mm |  |  |

**Zubehör / Accessories / Accessoires**

**Einfachlaufschiene, Alu, gelocht**

Running track, aluminium, pre-drilled  
Rail de roulement, en alu, perforé

Gr./Size

Art. No.

|         |              |
|---------|--------------|
| 1700 mm | 057.3037.170 |
| 2000 mm | 057.3037.200 |
| 2500 mm | 057.3037.250 |
| 6000 mm | 057.3037.600 |

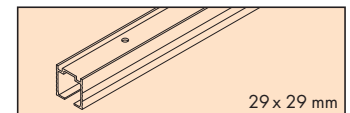

**Winkel-Set für Wandmontage, Stahl verzinkt**

Angle-bracket set for wall mounting, zinc-plated steel  
Lot d'équerres de fixation murale, en acier zingué

10x

057.3005.172

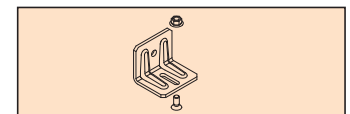

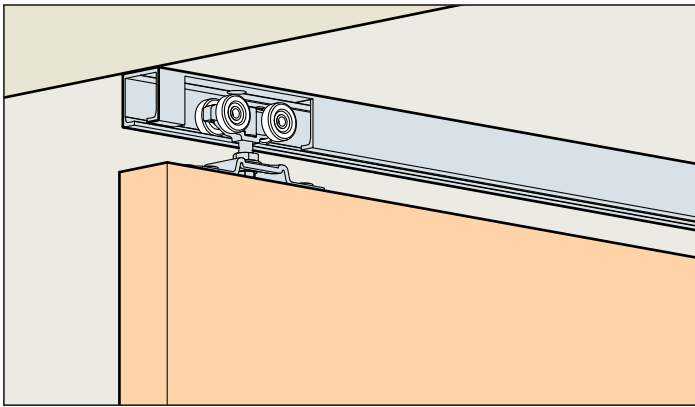

**System: Laufschiene für Decken- oder Wandmontage, für 1 Holztüre bis 60/100 kg.**

System: Running track for ceiling or wall mounting, for 1 wooden door up to 60/100 kg.

Système: Rail de roulement pour montage au plafond ou mural, pour 1 porte en bois jusqu'à 60/100 kg.

**Einbauvariante**

Mounting options

Variantes de montage

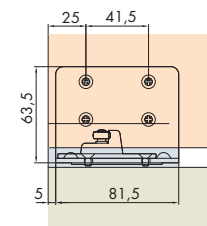
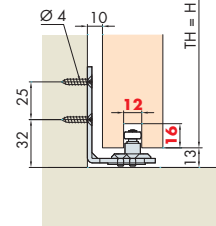
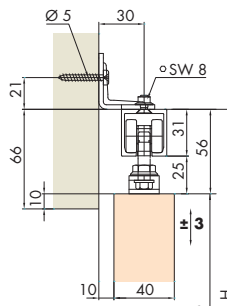
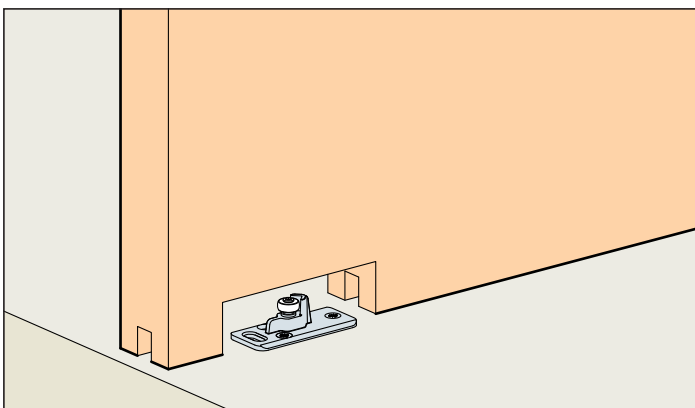

**Einbaubeispiele / Mounting examples / Exemples de montage**

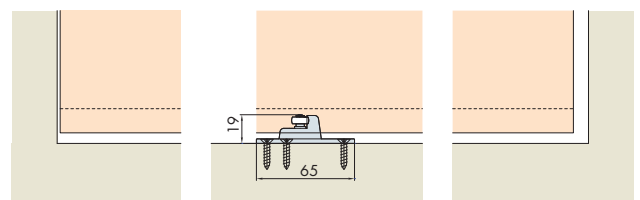
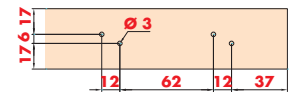
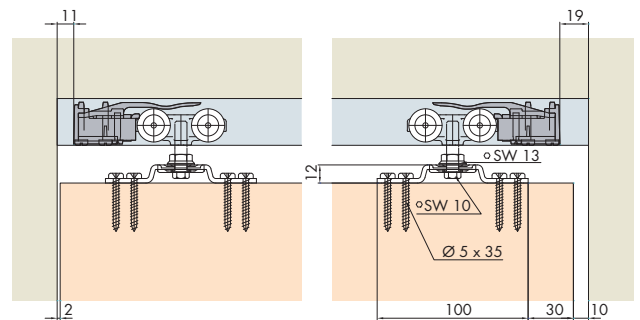
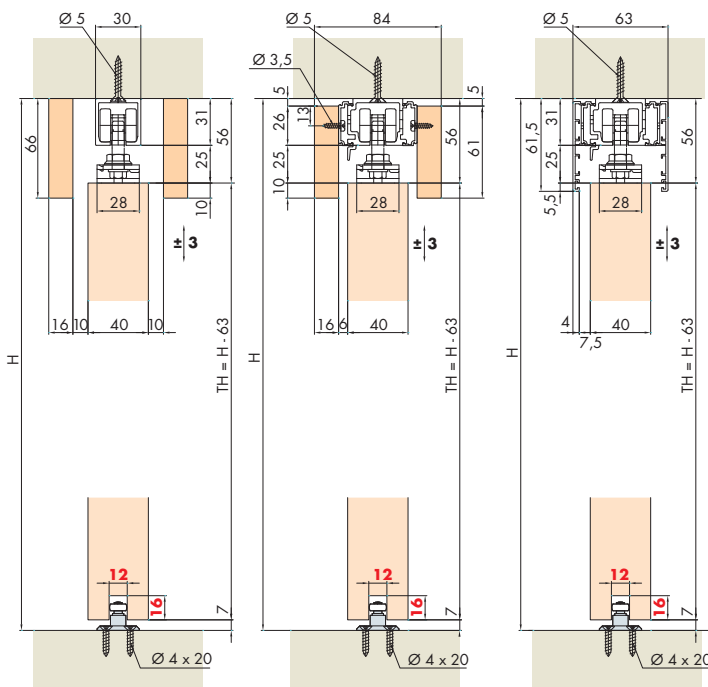



**Garnituren / Sets / Garnitures**

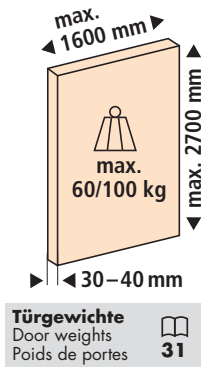

| EKU-PORTA 60/100  |   |
|-------------------|---|
| 1 Türe Door Porte | 60 No. 057.3138.071<br>100 No. 057.3139.071 |
| 2x                | 2x  |
| 1x                | 2x  |
| 2x                |   |

| EKU-PORTA 60                       |                  |
|------------------------------------|------------------|
| 1 Türe Door Porte                  | No. 057.3140.071 |
| 2x                                 | 2x               |
| 1x                                 | 2x               |
| 2x                                 |                  |
| Alu Aluminium Alu<br>2000x30x31 mm |                  |

| EKU-PORTA 100  |                  |
|--|------------------|
| 1 Türe Door Porte  | No. 057.3141.071 |
| 2x   | 2x               |
| 1x   | 2x               |
| 2x   | 1x               |
| Alu eloxiert Aluminium anodized Alu anodisé<br>2000x30x31 mm |                  |

**Zubehör / Accessories / Accessoires**

**Einfachlaufschiene, Alu, gelocht**

Running track, aluminium, pre-drilled  
Rail de roulement, en alu, perforé

| Gr./Size | Art. No.     |
|----------|--------------|
| 1500 mm  | 057.3016.150 |
| 1700 mm  | 057.3016.170 |
| 2000 mm  | 057.3016.200 |
| 2500 mm  | 057.3016.250 |
| 6000 mm  | 057.3016.600 |

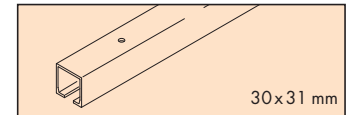

**Einfachlaufschiene, Alu eloxiert, gelocht**

Running track, aluminium anodized, pre-drilled  
Rail de roulement, en alu anodisé, perforé

|         |              |
|---------|--------------|
| 2000 mm | 057.3016.201 |
| 2500 mm | 057.3016.251 |
| 6000 mm | 057.3016.601 |

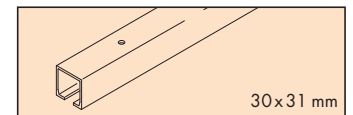

**Winkel-Set für Wandmontage, Stahl verzinkt**

Angle-bracket set for wall mounting, zinc-plated steel  
Lot d'équerres de fixation murale, en acier zingué

|     |              |
|-----|--------------|
| 10x | 057.3005.172 |
|-----|--------------|

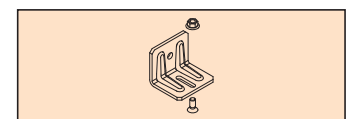

**Combi-Laufschiene, Alu, gelocht**

Combi running track, aluminium, pre-drilled  
Rail de roulement Combi, en alu, perforé

|         |              |
|---------|--------------|
| 2000 mm | 057.3048.200 |
| 2500 mm | 057.3048.250 |
| 3500 mm | 057.3048.350 |
| 6000 mm | 057.3048.600 |

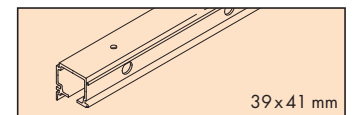

**Clip-Blende, Alu eloxiert, für Wandmontage**

Clip fascia, aluminium anodized, for wall mounting  
Cache à clipser, en alu anodisé, montage mural

|         |              |
|---------|--------------|
| 2500 mm | 042.3004.250 |
| 3500 mm | 042.3004.350 |
| 6000 mm | 042.3004.600 |

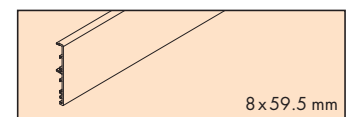

**Clip-Teil für Holz- und Alublende, Alu, gelocht (alle 500 mm)**

Clip component for wooden and aluminium fascia, aluminium pre-drilled (every 500 mm)  
Clip pour cache en bois ou en alu, en alu, perforé (tous les 500 mm)

|              |
|--------------|
| 057.3117.001 |
|--------------|

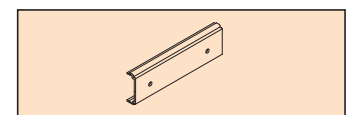

**Sonderzubehör / Special accessories / Accessoires spéciaux:** ☞ 18

**Einzelteile / Components / Pièces détachées:** ☞ 20

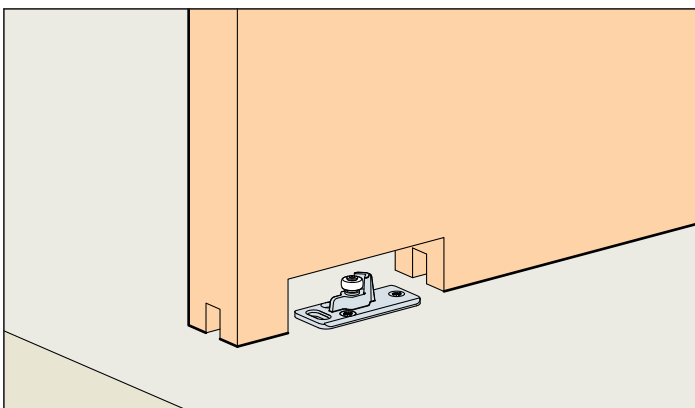
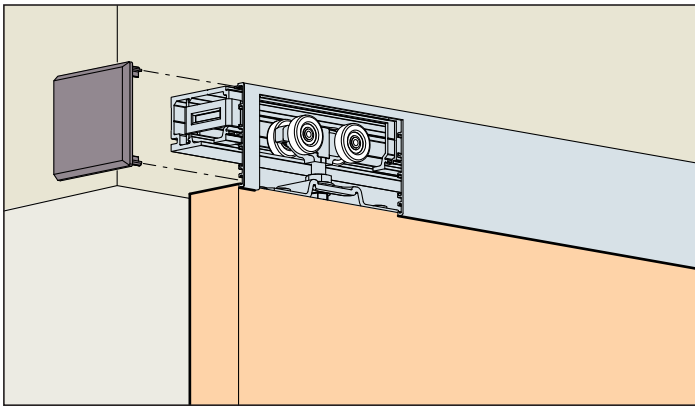

**System: Laufschiene für Wandmontage, für 1 Holztüre bis 60/100 kg.**

System: Running tracks for wall mounting, for 1 wooden door up to 60/100 kg.

Système: Rail de roulement pour montage mural, pour 1 porte en bois jusqu'à 60/100 kg.

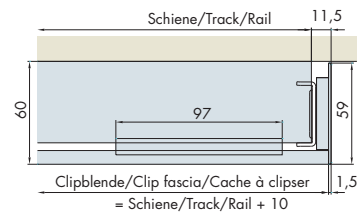
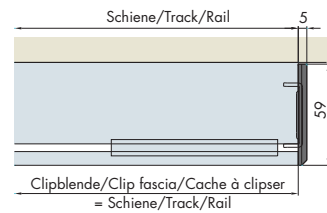
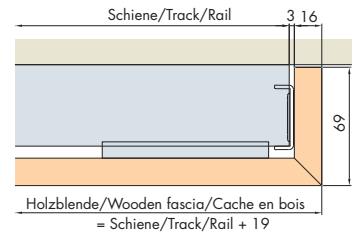

**Einbaubeispiele / Mounting examples / Exemples de montage**

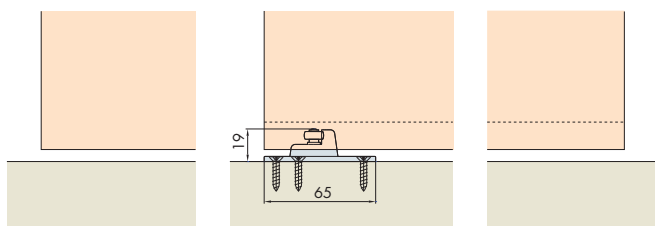
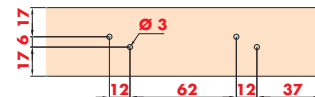
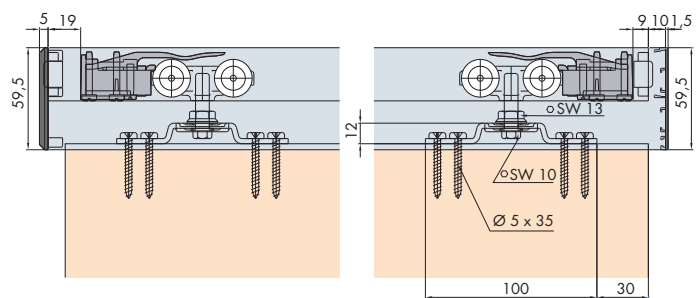
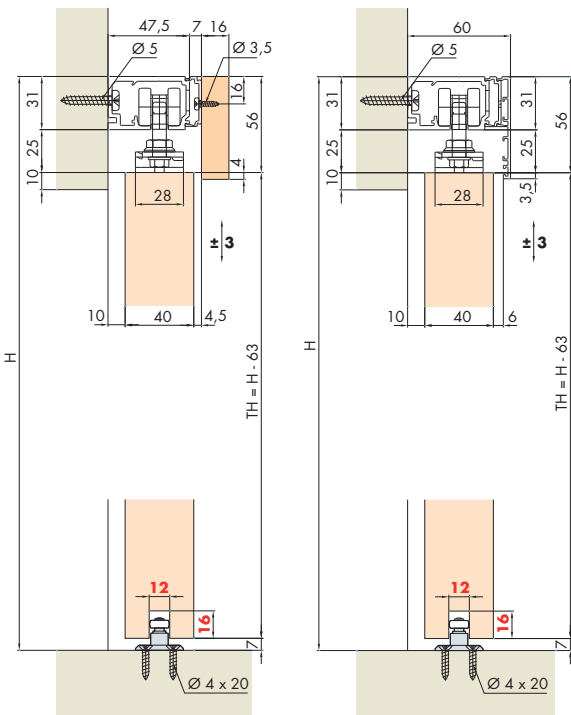

**Garnituren / Sets / Garnitures**

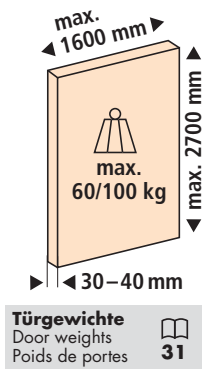

| EKU-PORTA 60/100  |   |
|-------------------|---|
| 1 Türe Door Porte | 60 No. 057.3138.071<br>100 No. 057.3139.071 |
| 2x                | 2x  |
| 2x                | 2x  |
| 1x                | 2x  |
| 2x                | 5x  |

| EKU-PORTA 60      |                  |
|-------------------|------------------|
| 1 Türe Door Porte | No. 057.3142.071 |
| 2x                | 2x               |
| 1x                | 2x               |
| 2x                | 5x               |
| 2000x47.5x31 mm   |                  |

| EKU-PORTA 100     |                  |
|-------------------|------------------|
| 1 Türe Door Porte | No. 057.3143.071 |
| 2x                | 2x               |
| 2x                | 1x               |
| 1x                | 2x               |
| 1x                | 5x               |
| 2000x47.5x31 mm   |                  |
| 2000x8x59.5 mm    |                  |

**Einbauvariante**

Mounting options  
Variantes de montage

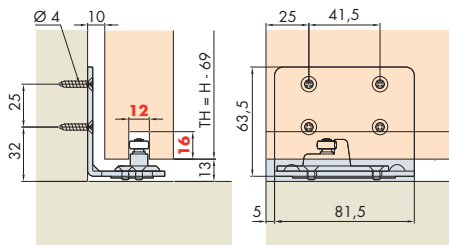

**Zubehör / Accessories / Accessoires**

**Einfachlaufschiene, Alu eloxiert, gelocht**

Running track, aluminium anodized, pre-drilled  
Rail de roulement, en alu anodisé, perforé

| Gr./Size | Art. No.     |
|----------|--------------|
| 2500 mm  | 057.3112.250 |
| 3500 mm  | 057.3112.350 |
| 6000 mm  | 057.3112.600 |

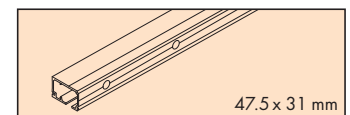

**Clip-Blende, Alu eloxiert, für Wandmontage**

Clip fascia, aluminium anodized, for wall mounting  
Cache à clipser, en alu anodisé, montage mural

|         |              |
|---------|--------------|
| 2500 mm | 042.3004.250 |
| 3500 mm | 042.3004.350 |
| 6000 mm | 042.3004.600 |

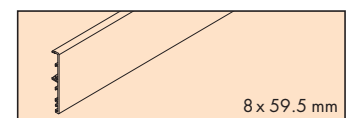

**Clip-Teil für Holz- und Alublende, Alu, gelocht (alle 500 mm)**

Clip component for wooden and aluminium fascia, aluminium pre-drilled (every 500 mm)  
Clip pour cache en bois ou en alu, en alu, perforé (tous les 500 mm)

057.3117.001

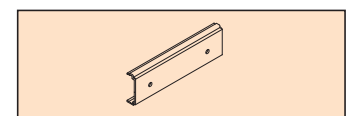

**Begrenzer für Holzblende**

Limiter for wooden fascia  
Limiteur pour cache en bois

057.3126.071

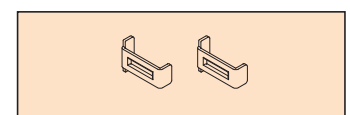

**Blendenendstück-Set, Alu eloxiert, inkl. Begrenzer, für Alublende**

Fascia end component set, aluminium anodized, incl. limiter, for aluminium fascia  
Jeu d'extrémités de cache, en alu anodisé, avec limiteur, pour cache en alu

042.3028.076

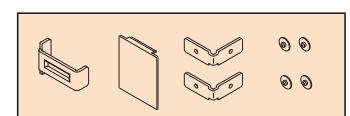

**Endkappen-Set, Kunststoff anthrazit, inkl. Begrenzer, für Alublende**

End cap set, plastic anthracite, incl. limiter, for aluminium fascia  
Jeu d'embouts, plastique anthracite, avec limiteur, pour cache en alu

057.3132.072

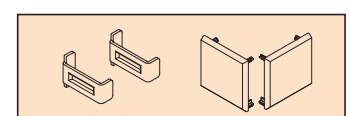

**Sonderzubehör / Special accessories / Accessoires spéciaux:** ☐ 18

**Einzelteile / Components / Pièces détachées:** ☐ 20

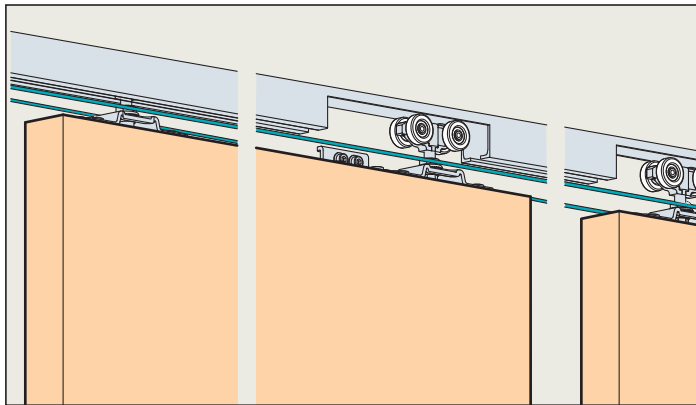

**Systemzusatz: Synchro für 2 synchronlaufende Holztüren mit Kevlarseil, zu EKU-PORTA 60/100 H/HC**

System addition: Synchro for 2 synchronized running wooden doors with kevlar rope, for EKU-PORTA 60/100 H/HC

Supplément de système: Synchro pour 2 portes en bois synchronisé avec câble kevlar, pour EKU-PORTA 60/100 H/HC

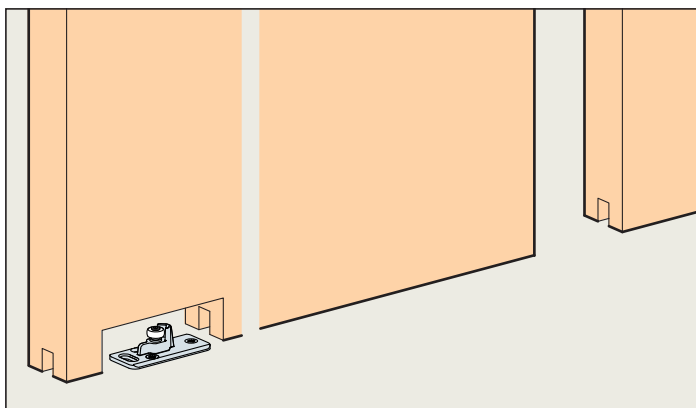

**Einbaubeispiele / Mounting examples / Exemples de montage**

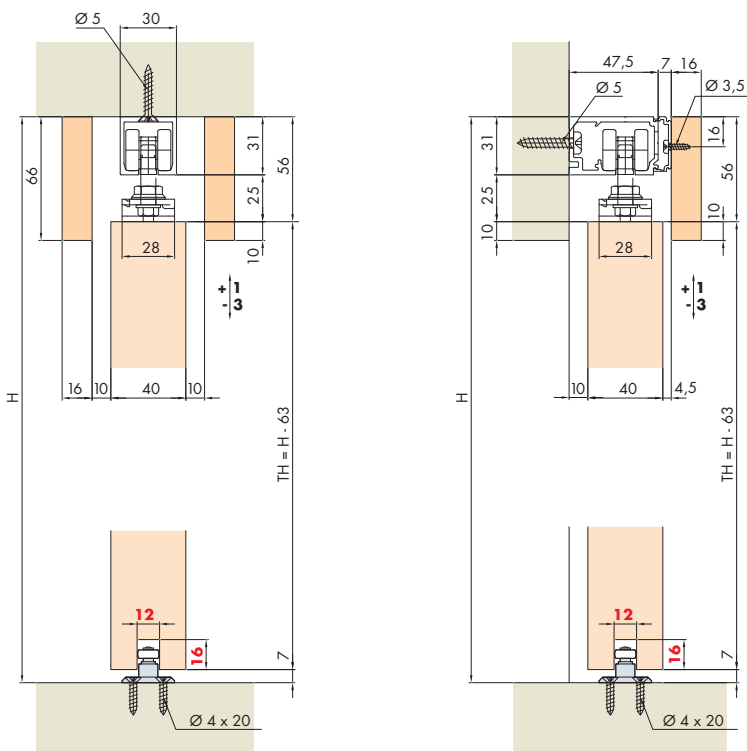

**Türbearbeitung = rote Zahlen / Door treatment = red numbers / Traitement de portes = numéros en rouge**

Garnituren / Sets / Garnitures

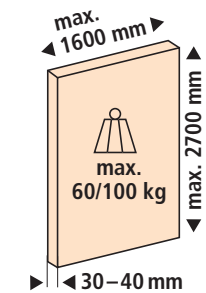

Türgewichte  
Door weights  
Poids de portes **31**

| EKU-PORTA 60/100        |  |
|-------------------------|--|
| 1 Türe<br>Door<br>Porte | 60 No. 057.3138.071<br>100 No. 057.3139.071  |
| 2x                      | 2x   |
| 1x                      | 2x   |
| 2x                      | <b>Bitte 2 Garnituren bestellen</b><br>Please order 2 sets<br>A commander 2 garnitures |

| EKU-PORTA Synchro          |                  |
|----------------------------|------------------|
| 2 Türen<br>Doors<br>Portes | No. 042.3027.072 |
| 2x                         | 2x               |
| 2x                         | 2x               |
| 1x                         | 1x               |

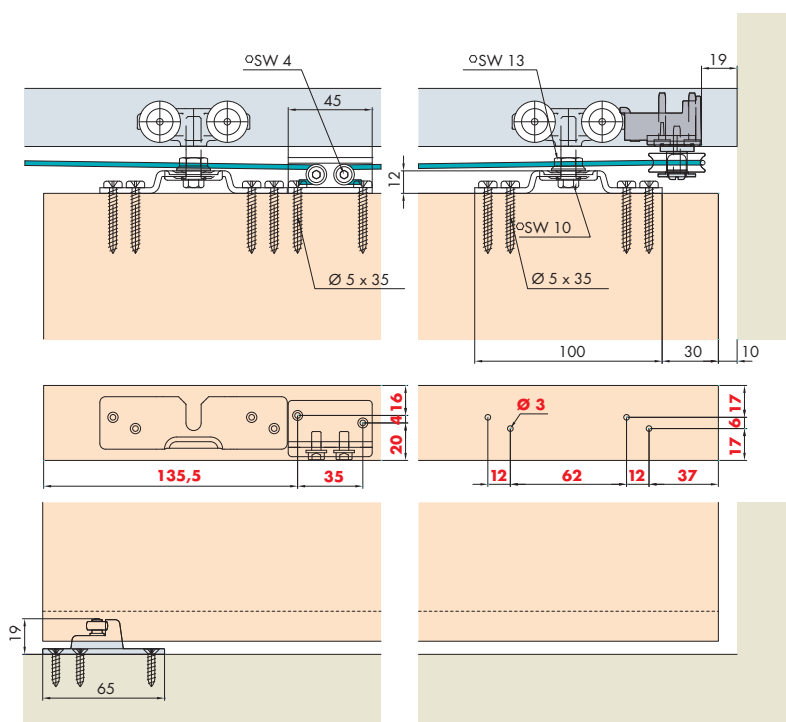
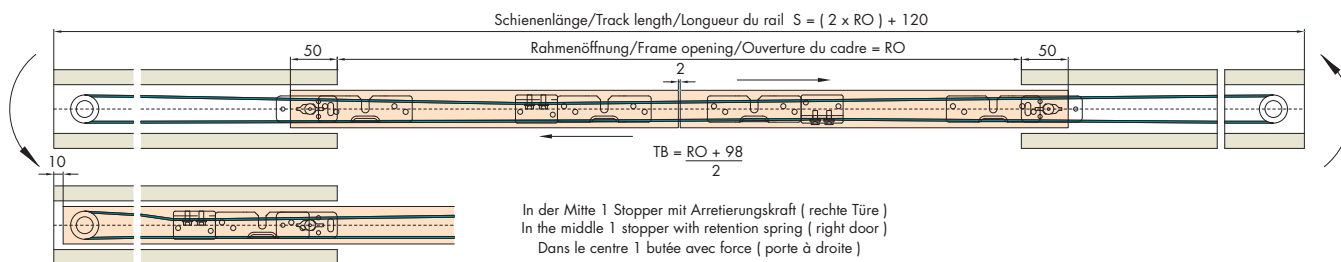

Sonderzubehör / Special accessories / Accessoires spéciaux: 18

Einzelteile / Components / Pièces détachées: 20

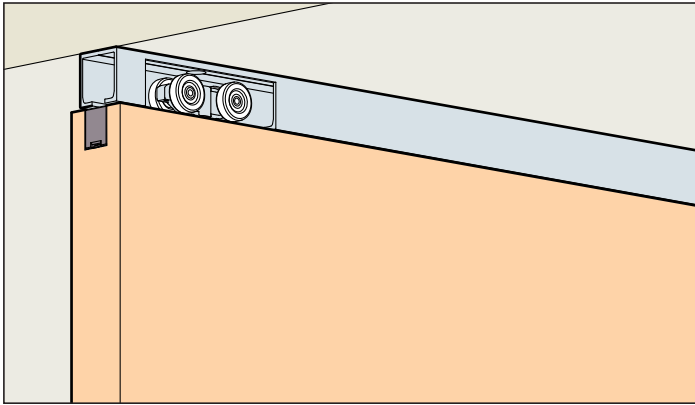

**System: Laufschiene für Deckenmontage, Einbauhöhe 31 mm, einsetzbar aufgesetzt oder deckenbündig, für 1 Holztüre bis 60/100 kg.**

System: Running track for ceiling mounting, installation height 31 mm, surface mounted or flush with the ceiling, for 1 wooden door up to 60/100 kg.

Système: Rail de roulement pour montage au plafond, hauteur d'installation 31 mm, montage en applique ou affleurant avec le plafond, pour 1 porte en bois jusqu'à 60/100 kg.

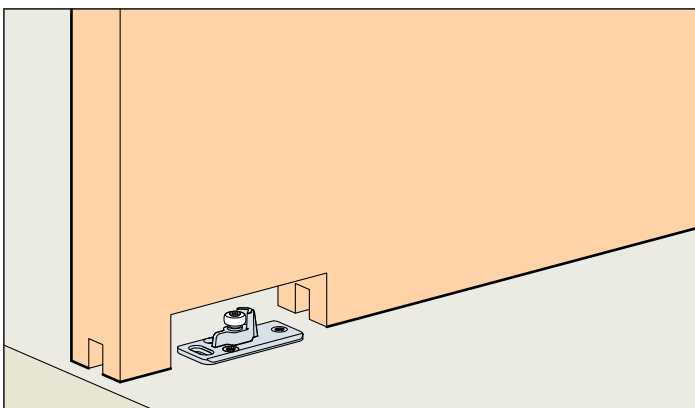

**Einbaubeispiele / Mounting examples / Exemples de montage**

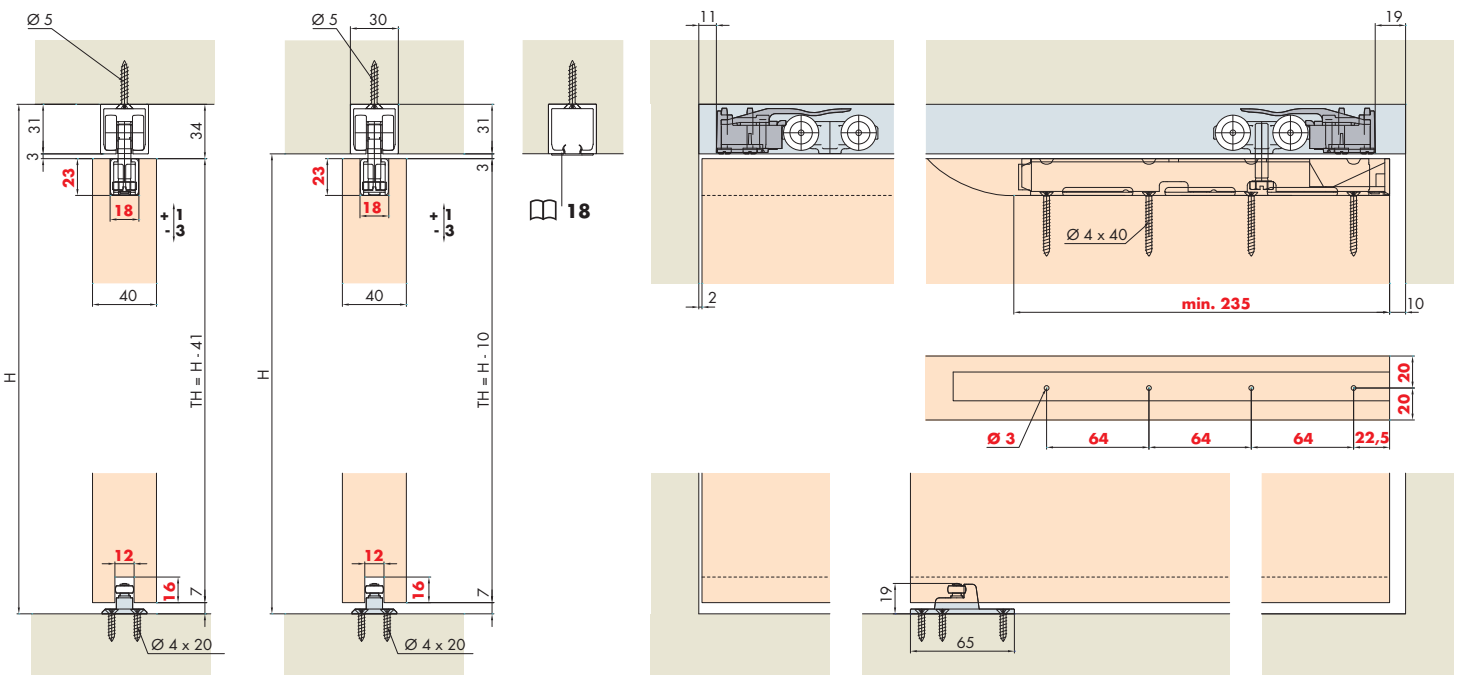



**Garnituren / Sets / Garnitures**

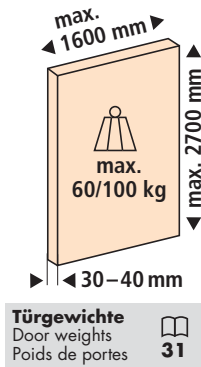

| EKU-PORTA 60/100        |   |
|-------------------------|---|
| 1 Türe<br>Door<br>Porte | 60 No. 057.3133.072<br>100 No. 057.3133.071 |
| 2x                      | 2x 2x                                       |
| 2x                      | 2x  |
| 1x                      | 1x  |

| EKU-PORTA 60                             |                  |
|--|------------------|
| 1 Türe<br>Door<br>Porte                  | No. 057.3134.071 |
| 2x                                       | 2x 2x            |
| 2x                                       | 2x               |
| 1x                                       | 1x               |
| Alu<br>Aluminium<br>Alu<br>2000x30x31 mm |                  |

| EKU-PORTA 100  |                  |
|--|------------------|
| 1 Türe<br>Door<br>Porte  | No. 057.3135.071 |
| 2x   | 2x 2x            |
| 2x   | 1x 2x            |
| 1x   | 1x               |
| Alu eloxiert<br>Aluminium anodized<br>Alu anodisé<br>2000x30x31 mm |                  |

**Zubehör / Accessories / Accessoires**

**Einfachlaufschiene, Alu, gelocht**

Running track, aluminium, pre-drilled  
Rail de roulement, en alu, perforé

Gr./Size Art. No.

|         |              |
|---------|--------------|
| 1500 mm | 057.3016.150 |
| 1700 mm | 057.3016.170 |
| 2000 mm | 057.3016.200 |
| 2500 mm | 057.3016.250 |
| 6000 mm | 057.3016.600 |

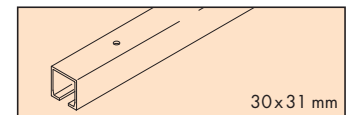

**Einfachlaufschiene, Alu eloxiert, gelocht**

Running track, aluminium anodized, pre-drilled  
Rail de roulement, en alu anodisé, perforé

|         |              |
|---------|--------------|
| 2000 mm | 057.3016.201 |
| 2500 mm | 057.3016.251 |
| 6000 mm | 057.3016.601 |

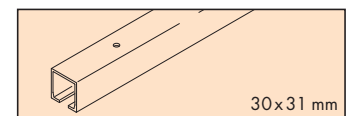

**Sonderzubehör / Special accessories / Accessoires spéciaux:** ☐ 18

**Einzelteile / Components / Pièces détachées:** ☐ 20

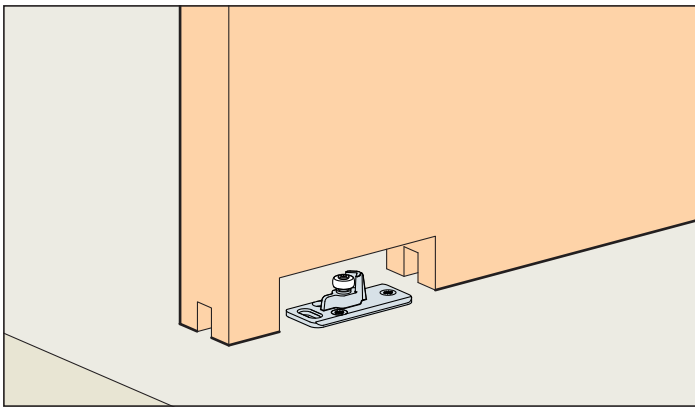
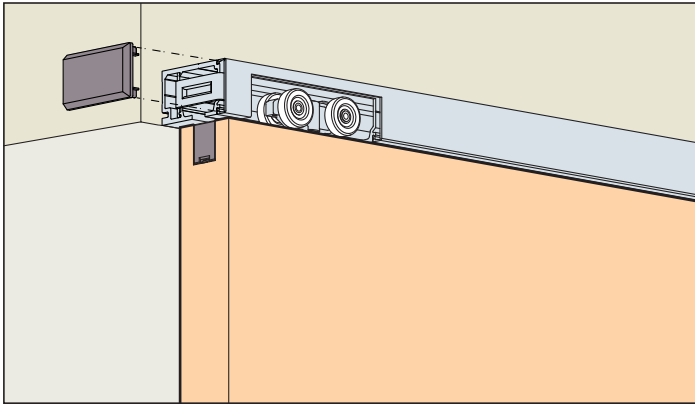

**System: Designlaufschiene für Wandmontage, Einbauhöhe 31mm, für 1 Holztüre bis 60/100 kg.**

System: Design running track for wall mounting, installation height 31 mm, for 1 wooden door up to 60/100 kg.

Système: Rail de roulement design pour montage mural, hauteur d'installation 31 mm, pour 1 porte en bois jusqu'à 60/100 kg.

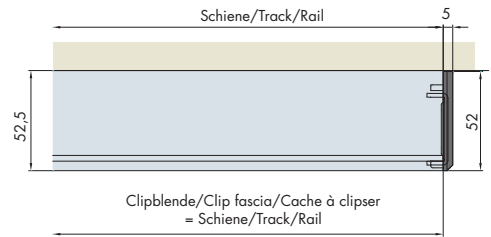
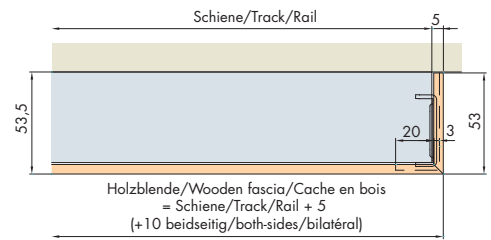

**Einbaubeispiele / Mounting examples / Exemples de montage**

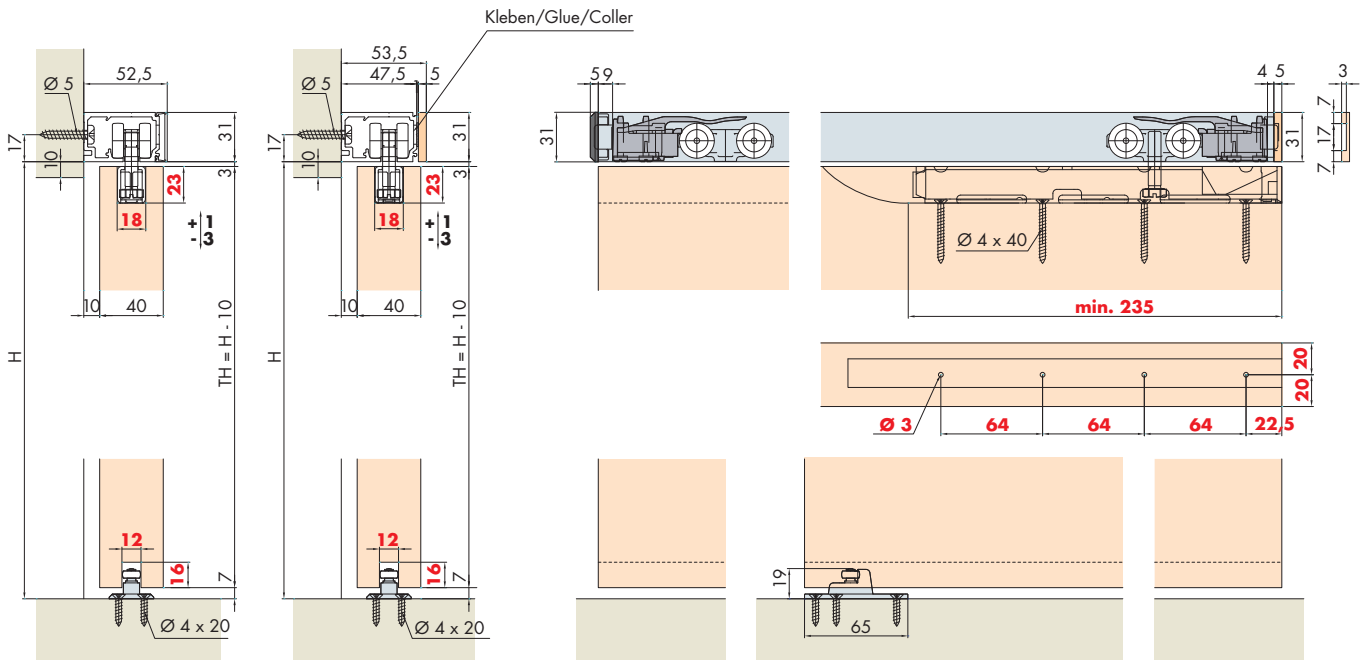

**Garnituren / Sets / Garnitures**

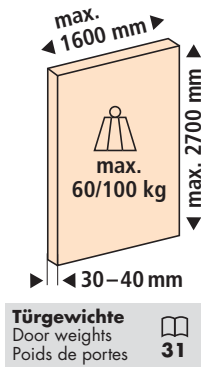

| EKU-PORTA 60/100  |   |
|-------------------|---|
| 1 Türe Door Porte | 60 No. 057.3133.072<br>100 No. 057.3133.071 |
| 2x                | 2x  |
| 2x                | 2x  |
| 1x                | 1x  |

| EKU-PORTA 60      |                  |
|-------------------|------------------|
| 1 Türe Door Porte | No. 057.3136.071 |
| 2x                | 2x               |
| 2x                | 2x               |
| 2x                | 1x               |
| 2x                | 2x               |
| 2x                | 2x               |
| 2000x47.5x31 mm   |                  |

| EKU-PORTA 100     |                  |
|-------------------|------------------|
| 1 Türe Door Porte | No. 057.3137.071 |
| 2x                | 2x               |
| 2x                | 2x               |
| 2x                | 1x               |
| 2x                | 2x               |
| 2x                | 1x               |
| 2x                | 1x               |
| 2000x47.5x31 mm   |                  |
| 2000x7.5x31 mm    |                  |
| 1x                |                  |

**Einbauvariante**

Mounting options  
Variantes de montage

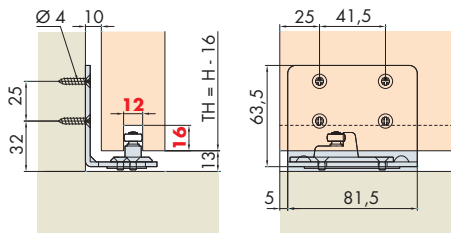

**Zubehör / Accessories / Accessoires**

**Einfachlaufschiene, Alu eloxiert, gelocht**

Running track, aluminium anodized, pre-drilled  
Rail de roulement, en alu anodisé, perforé

Gr./Size Art. No.

2500 mm 057.3112.250  
3500 mm 057.3112.350  
6000 mm 057.3112.600

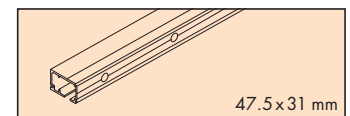

**Clip-Blende, Alu eloxiert, für Wandmontage**

Clip fascia, aluminium anodized, for wall mounting  
Cache à clipser, en alu anodisé, montage mural

2500 mm 057.3113.250  
3500 mm 057.3113.350  
6000 mm 057.3113.600

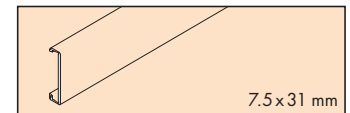

**Endkappen-Set, Kunststoff anthrazit, inkl. Begrenzer, für Alublende**

End cap set, plastic anthracite, incl. limiter, for aluminium fascia  
Jeu d'embouts, plastique anthracite, avec limiteur, pour cache en alu

057.3131.072

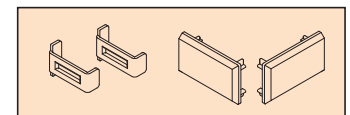

**Begrenzer für Holzblende**

Limiter for wooden fascia  
Limiteur pour cache en bois

057.3126.071

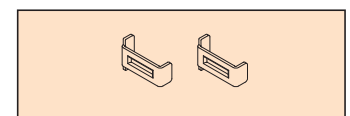

**Sonderzubehör / Special accessories / Accessoires spéciaux:** ☐ 18

**Einzelteile / Components / Pièces détachées:** ☐ 20

## EKU-PORTA 45/60/100

**Winkel-Set für Wandmontage, Stahl verzinkt**

Angle-bracket set for wall mounting, zinc-plated steel  
 Lot d'équerres de fixation murale, en acier zingué

Gr./Size

10x

Art. No.

057.3005.172

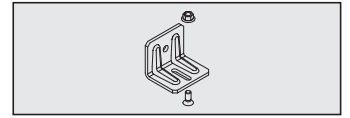
**Schienen-Verbindungs-U EKU-PORTA 60/100, Stahl verzinkt, gelocht**

Track connecting U-piece EKU-PORTA 60/100, zinc-plated steel, pre-drilled  
 Raccord en U pour rails EKU-PORTA 60/100, en acier zingué, perforé

057.3025.101

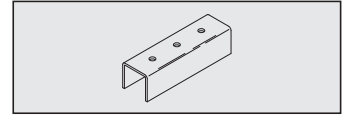
**Einfachlaufschiene EKU-PORTA 60/100, Stahl verzinkt, gelocht 6000 mm**

Running track EKU-PORTA 60/100, zinc-plated steel, pre-drilled  
 Rail de roulement EKU-PORTA 60/100, en acier zingué, perforé

057.3022.600

**Wandausgleichsprofil, Alu eloxiert, mit Dichtungsprofil**

Wall compensation profile, aluminium anodized, with sealing profile  
 Profil de compensation murale, en alu anodisé, avec profil d'étanchéité

2500 mm

042.3064.071

3000 mm

042.3064.072

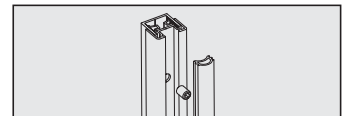
**Einwegabdeckung für Laufschiene 057.3016, Kunststoff**

Disposable cover for running track 057.3016, plastic  
 Recouvrement de rail 057.3016 à usage unique, plastique

2000 mm

057.3098.001

**Schienenreiniger, Kunststoff grau**

Track cleaner, plastic grey  
 Nettoyant pour rails, plastique gris

057.3099.071

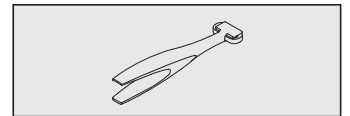
**T-Bodenführungs-Set EKU-PORTA 45 für Wandmontage**

T-floor-guide set EKU-PORTA 45, for wall mounting  
 Guidage au sol en T EKU-PORTA 45, de fixation murale

057.3015.071

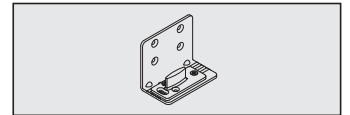
**Bodenführungs-Set mit Rolle EKU-PORTA 60/100, für Wandmontage**

Floor-guide set with roller EKU-PORTA 60/100, for wall mounting  
 Guidage au sol avec chariot EKU-PORTA 60/100, de fixation murale

057.3128.171

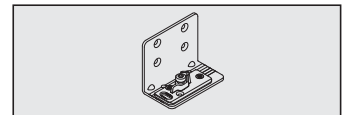

## EKU-PORTA 45

**Laufwerk, Gleitlager, Gehäuse Kunststoff rot, Rollen Kunststoff blau**

Runner, plain bearings, housing plastic red, rollers plastic blue

Chariot, patin glisseur, boîtier plastique rouge, galets plastique bleu

**Tragschraube M8 x 35, Stahl verzinkt**

Suspension bolt M8 x 35, zinc-plated steel

Vis porteuse M8 x 35, acier zingué

**Mutter M8, Stahl verzinkt**

Nut M8, zinc-plated steel

Ecrou M8, en acier zingué

**Tragflansch, höhen- und seitenverstellbar, Stahl verzinkt**

Support bracket, height and lateral adjustable, zinc-plated steel

Etrier de fixation, réglage en hauteur et latéral, en acier zingué

**T-Bodenführung, justierbar, Kunststoff antrazith**

T-floor-guide, adjustable, plastic anthracite

Guidage au sol en T, réglable, plastique anthracite

**Stopper, mit Rückhaltefeder, Kunststoff grau**

Stopper, with retention spring, plastic grey

Butée, avec ressort de blocage, plastique gris

Art. No.

057.3044.071

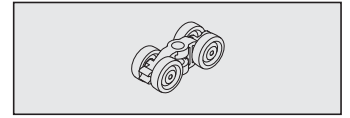

057.0123.101

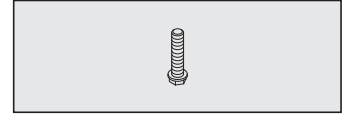

767.0808.100



057.3129.101

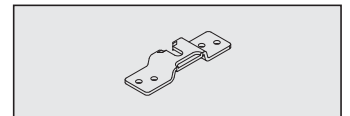

057.3010.001

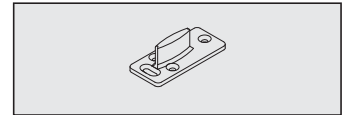

057.3038.071

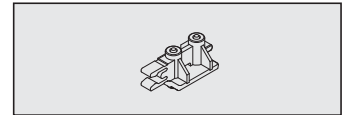

## EKU-PORTA 60/100

**Laufwerk EKU-PORTA 60, Gleitlager, Rollen Kunststoff blau**

Runner EKU-PORTA 60, plain bearings, rollers plastic blue  
 Chariots EKU-PORTA 60, patin glisseur, galets plastique bleu

Art. No.

057.3115.071

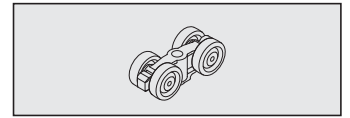
**Laufwerk EKU-PORTA 100, Kugellager, Rollen Kunststoff weiss**

Runner EKU-PORTA 100, ball bearings, rollers plastic white  
 Chariot EKU-PORTA 100, roulement à billes, galets plastique blanc

057.3114.071

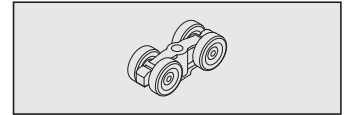
**Tragschraube M8 x 32, Stahl verzinkt**

Suspension bolt M8 x 32, zinc-plated steel  
 Vis porteuse M8 x 32, en acier zingué

057.0123.104

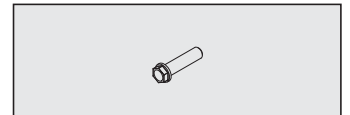
**Mutter M8, Stahl verzinkt**

Nut M8, zinc-plated steel  
 Ecrou M8, en acier zingué

768.9005.101

**Tragflansch, höhen- und seitenverstellbar, Stahl verzinkt**

Support bracket, height and lateral adjustable, zinc-plated steel  
 Etrier de fixation, réglage en hauteur et latéral, en acier zingué

057.3129.101

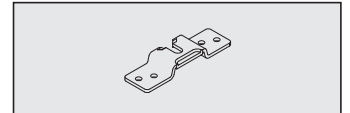
**Stopper, ohne Rückhaltefeder**

Stopper, without retention spring, plastic grey  
 Butée, sans ressort de blocage, plastique gris

057.3073.071

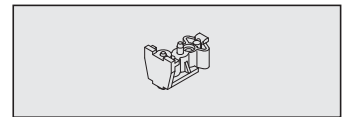
**Stopper, mit Rückhaltefeder, Kunststoff grau**

Stopper, with retention spring, plastic grey  
 Butée, avec ressort de blocage, plastique gris

057.3073.072

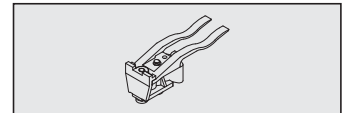
**Stopper, ohne Rückhaltefeder, Stahl verzinkt**

Stopper, without retention spring, zinc-plated steel  
 Butée, sans ressort de blocage, en acier zingué

057.3002.171

**Wandpuffer, Gummi schwarz**

Wall buffer, black rubber  
 Butoir mural, caoutchouc noir

024.0002.046

**Bodenführung mit Rolle, justierbar, Kunststoff antrazith**

Floor-guide with roller, adjustable, plastic anthracite  
 Guidage au sol avec chariot, réglable, plastique anthracite

057.3120.071

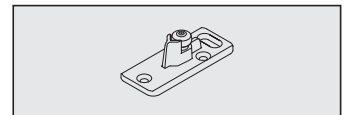



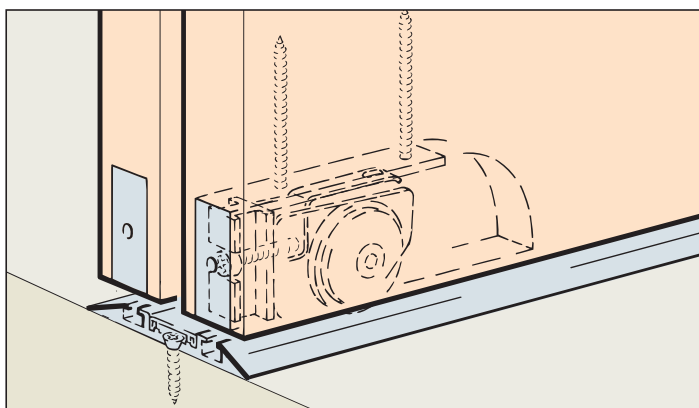

**System: Optionale 4-Punkt Führung**

System: Optional 4 point guide system

Système: En option guidage à 4 points

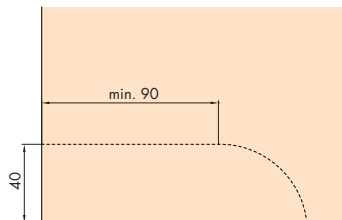

**Einbaubeispiele / Mounting examples / Exemples de montage**

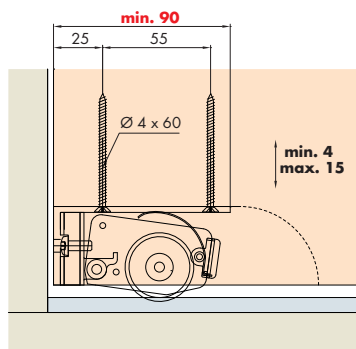
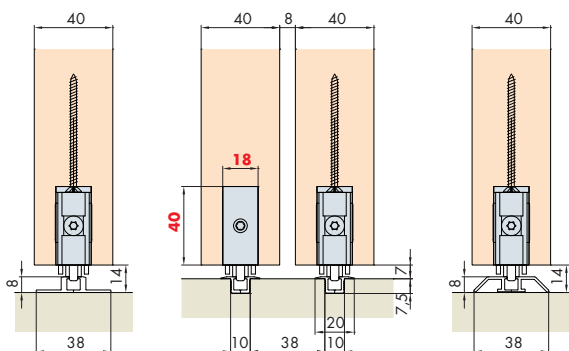

**Zubehör / Accessories / Accessoires**

Gr./Size

Art. No.

**Bodenführung**

Bottom guide

Guidage au sol

042.3033.071

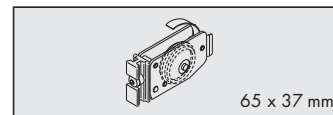

**Adapter, Kunststoff anthrazit, für Holztüren, zu 042.3033.071**

Adapter, plastic anthracite, for wooden doors, for 042.3033.071

Adaptateur, plastique anthracite, pour portes en bois, pour 042.3033.071

042.3036.001

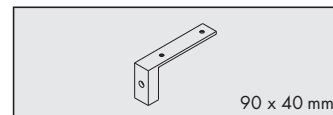

**Einfachführungsschiene, Alu, eloxiert**

Guide track, aluminium, anodized

Rail de guidage, en alu, anodisé

2500 mm

042.3089.250

3500 mm

042.3089.350

6000 mm

042.3089.600

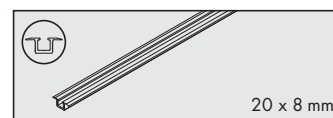

**Schienenendstück, Kunststoff grau, zu 042.3089**

Track end piece, plastic grey, for 042.3089

Pièce d'extrémité de rail, plastique gris, pour 042.3089

042.3090.081

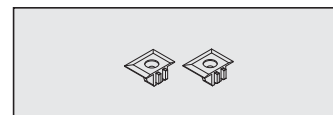

**Einfachlaufschiene, Alu, eloxiert**

Guide track, aluminium, anodized

Rail de guidage simple, en alu, anodisé

2500 mm

042.3040.250

3500 mm

042.3040.350

6000 mm

042.3040.600

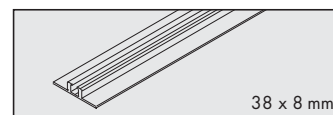

**Einfachführungsschiene, Alu, eloxiert, zum Kleben**

Guide track, aluminium, anodized, for gluing

Rail de guidage, en alu, anodisé, à coller

2500 mm

042.3080.250

3500 mm

042.3080.350

6000 mm

042.3080.600

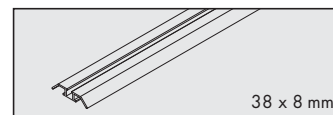

**Schienenendstück, Kunststoff grau, zu 042.3080**

Track end piece, plastic grey, for 042.3080

Pièce d'extrémité de rail, plastique gris, pour 042.3080

042.3087.081

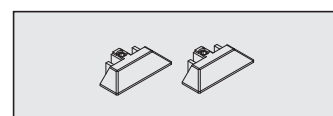

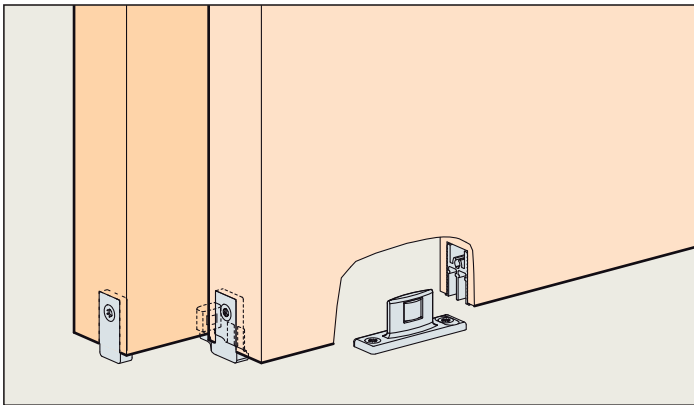

**System: Optionale Stapelung für barrierefreies und platzsparendes Stapeln von 2 Türen bis 60/100 kg.**

System: Optional stacking system for barrier-free and space saving stacking of 2 wooden doors up to 60/100 kg.

Système: En option empilage pour passage sans obstacle et permettant un gain de place pour 2 portes jusqu'à 60/100 kg,

**Einbaubeispiele / Mounting examples / Exemples de montage**

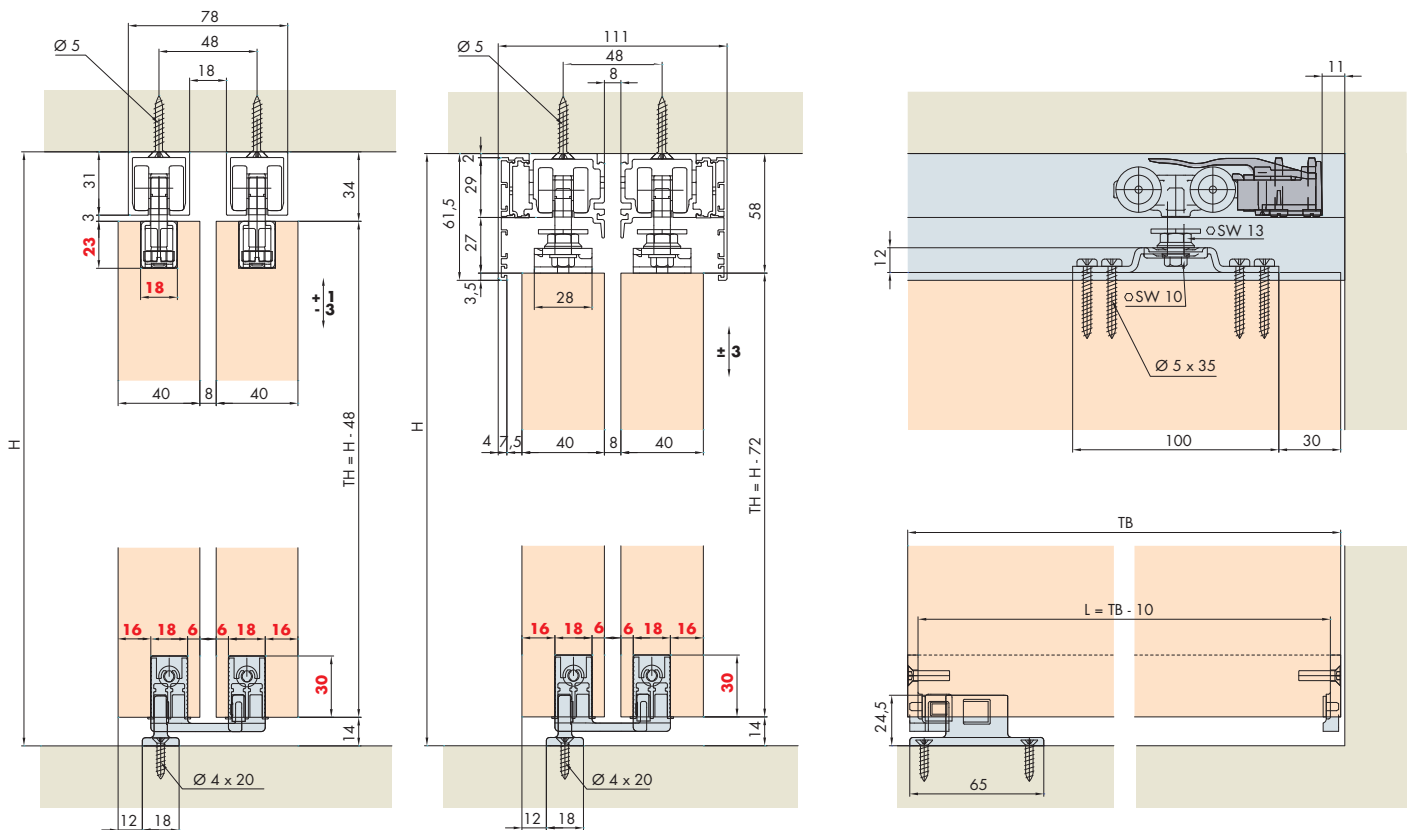

Türbearbeitung = rote Zahlen / Door treatment = red numbers / Traitement de portes = numéros en rouge

| Anzahl Türen<br>Number of doors<br>Nombre de portes      | Ausleger links<br>Left arm<br>Bras gauche<br>042.3097.071 | Ausleger rechts<br>Right arm<br>Bras droit<br>042.3098.071 | Abschlussplatte<br>End plate<br>Plaque d'extrémité<br>042.3099.071 |
|--|---|--|--|
| <b>2 Türen rechts</b><br>2 Right doors/2 Portes à droite |   | 1x   | 1x   |
| <b>2 Türen links</b><br>2 Left doors/2 Portes à gauche   | 1x  |  | 1x   |

**Garnituren / Sets / Garnitures**

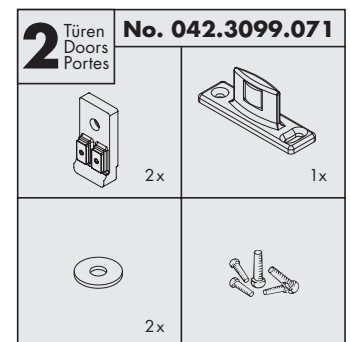
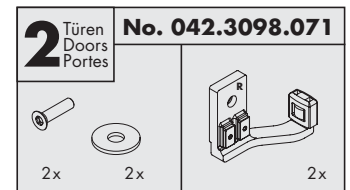
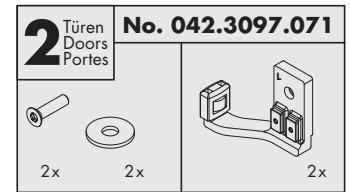

**Einbaubeispiel Ausleger links**

Mounting example **arm left**  
Exemple de montage **bras a gauche**

**Einbaubeispiel Ausleger rechts**

Mounting example **arm right**  
Exemple de montage **bras a droite**

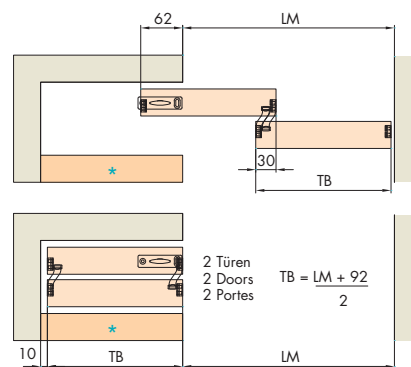
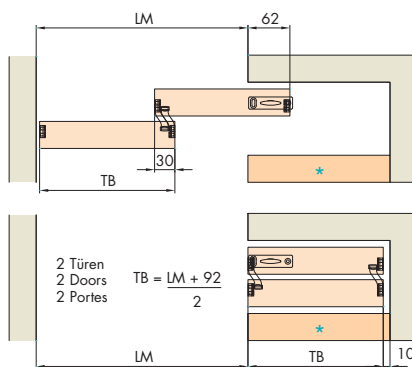
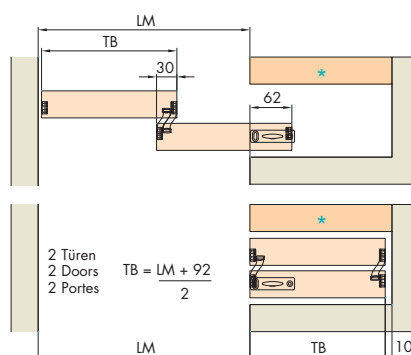
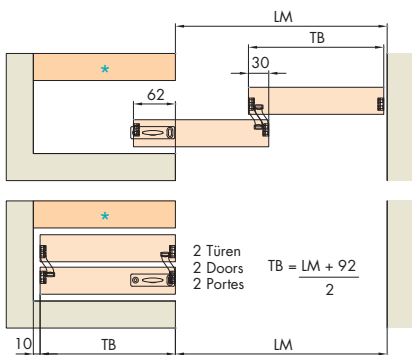

\* **Demontierbar für Montage**  
Removable for door mounting  
Démontable pour montage de porte

**Zubehör / Accessories / Accessoires**

**Doppelführungsschiene, Alu, zum Kleben**

Dual guide track, aluminium, for glueing  
Rail de guidage, en alu, à coller

Gr./Size Art. No.

2500 mm 042.3088.250  
3500 mm 042.3088.350  
6000 mm 042.3088.600

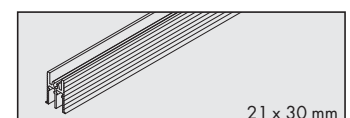

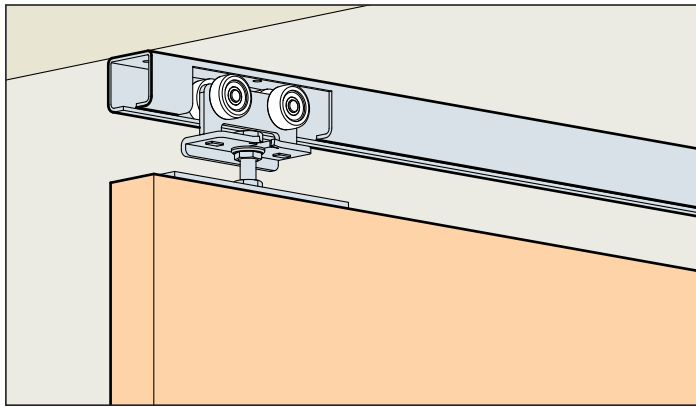

**System: Laufschiene für Decken- oder Wandmontage, für 1 Holztüre bis 300 kg.**

System: Running track for ceiling or wall mounting, for 1 wooden door up to 300 kg.

Système: Rail de roulement pour montage au plafond ou mural, pour 1 porte en bois jusqu'à 300 kg.

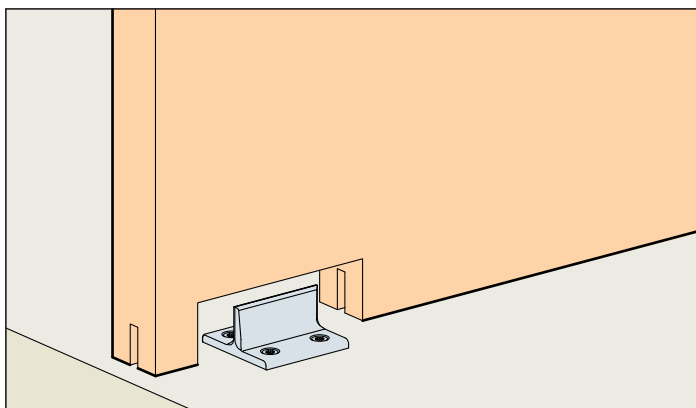

**Einbaubeispiele / Mounting examples / Exemples de montage**

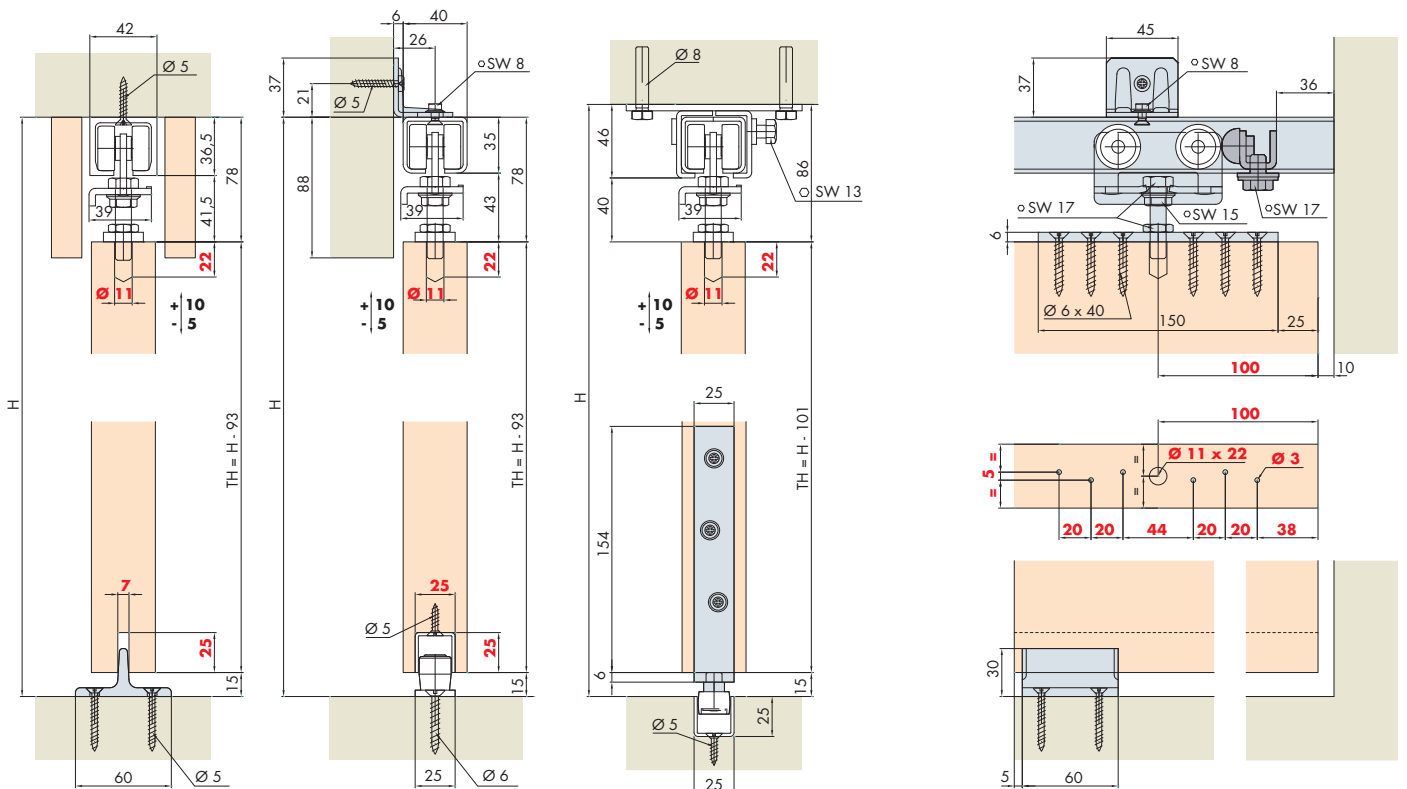



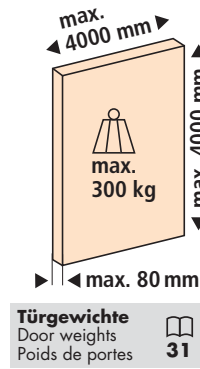
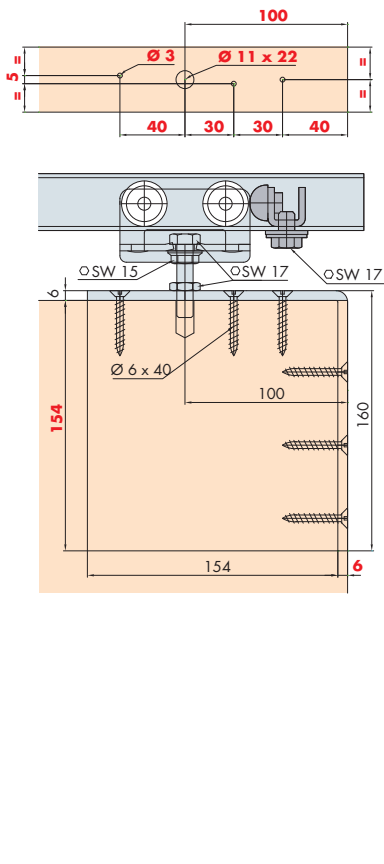

**Türbearbeitung = rote Zahlen / Door treatment = red numbers / Traitement de portes = numéros en rouge**

**Einbauvariante**

Mounting options  
Variantes de montage

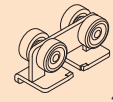
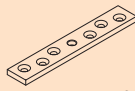

**Garnituren / Sets / Garnitures**

| 1 Türe Door Porte   |    | No. 058.3000.171  |    |
|---|----|---|----|
|  | 2x |  | 2x |
|  | 2x |  | 1x |
|  | 1x |  |    |

**Zubehör / Accessories / Accessoires**

**Einfachlaufschiene, Stahl**

Running track, steel  
Rail de roulement, en acier

**Einfachlaufschiene, Alu eloxiert, gelocht**

Running track, aluminium anodized, pre-drilled  
Rail de roulement, en alu anodisé, perforé

Gr./Size Art. No.

3000 mm 058.3002.300  
6000 mm 058.3002.600

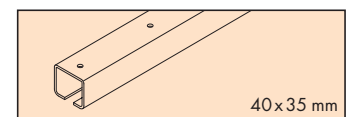

3000 mm 058.3016.300  
6000 mm 058.3016.600

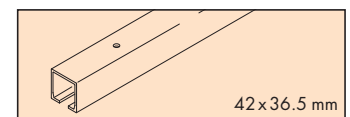

**Sonderzubehör / Special accessories / Accessoires spéciaux:** ☞ 28

**Einzelteile / Components / Pièces détachées:** ☞ 28

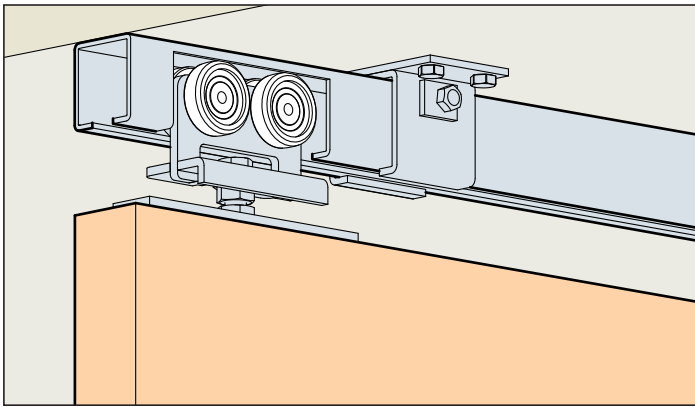

**System: Laufschiene für Decken- oder Wandmontage, für 1 Holztüre bis 600 kg.**

System: Running track for ceiling or wall mounting, for 1 wooden door up to 600 kg.

Système: Rail de roulement pour montage au plafond ou mural, pour 1 porte en bois jusqu'à 600 kg.

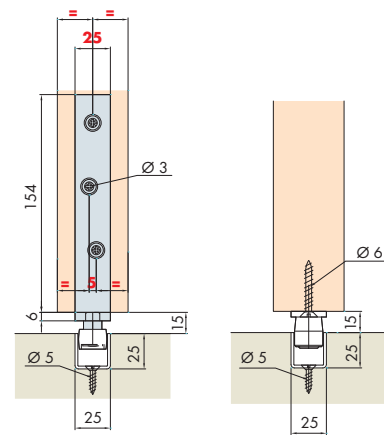
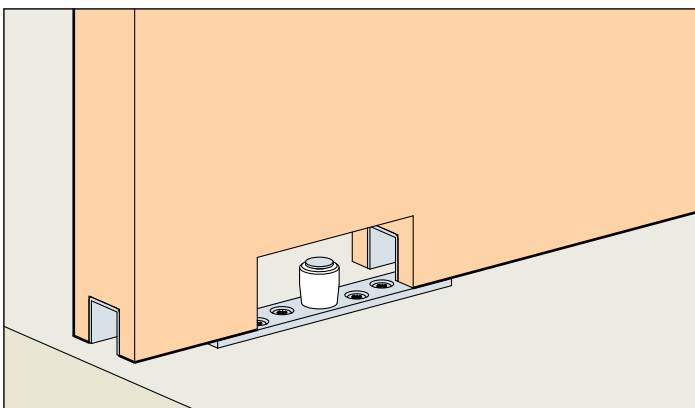

**Einbaubeispiele / Mounting examples / Exemples de montage**

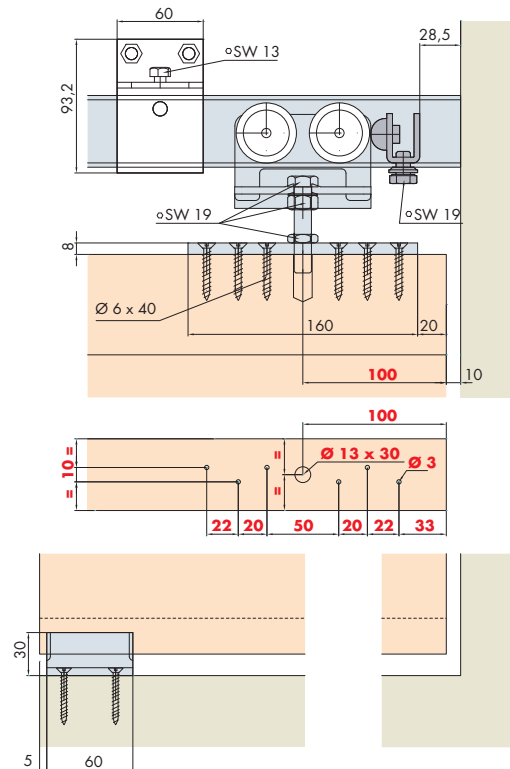
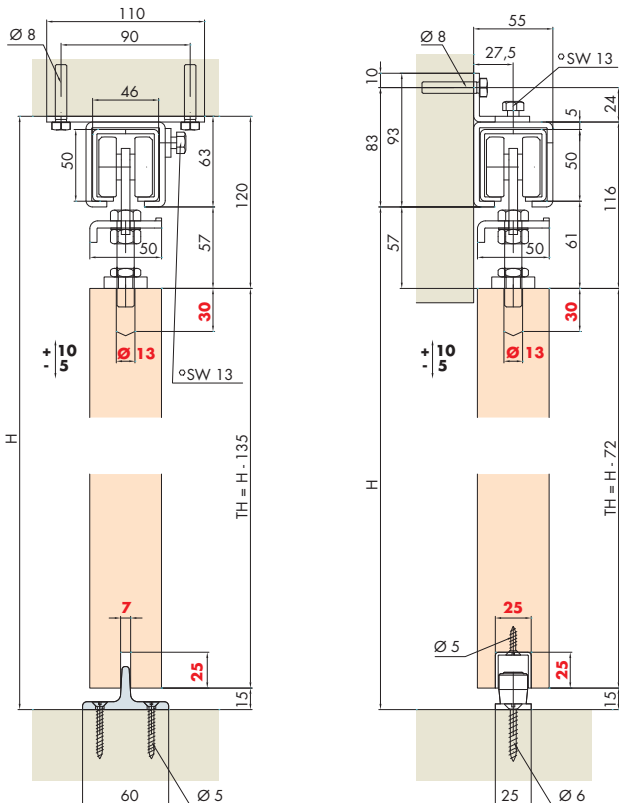

**Türbearbeitung = rote Zahlen / Door treatment = red numbers / Traitement de portes = numéros en rouge**





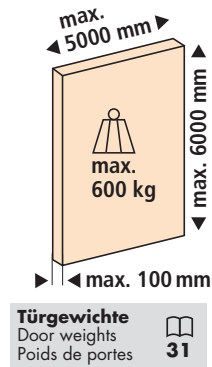
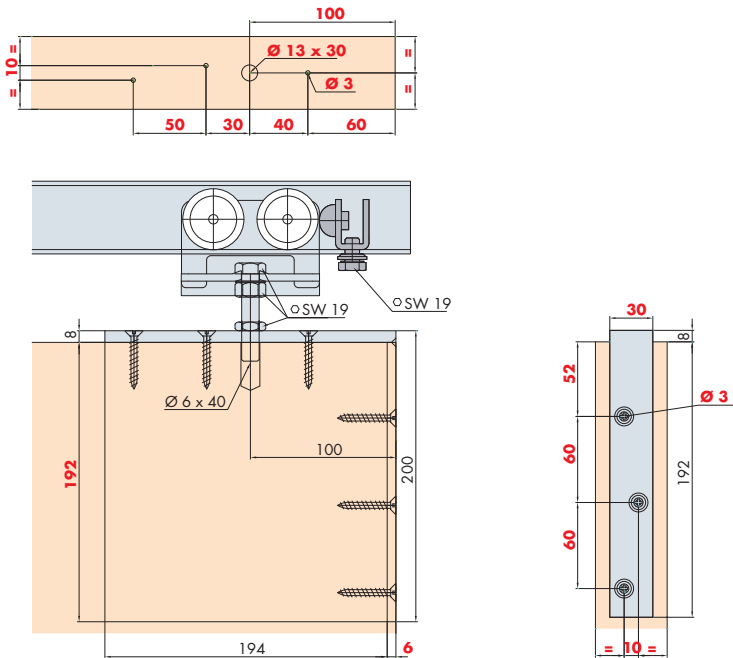

**Einbauvariante**

Mounting options  
Variantes de montage

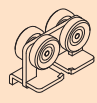
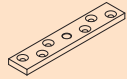

**Garnituren / Sets / Garnitures**

| 1 Türe Door Porte   |    | No. 059.3010.171  |    |
|---|----|---|----|
|  | 2x |  | 2x |
|  | 2x |  | 1x |
|  | 1x |  |    |

**Zubehör / Accessories / Accessoires**

Gr./Size Art. No.

**Einfachlaufschiene, Stahl**

Running track, steel  
Rail de roulement, en acier

6000 mm 059.3000.600

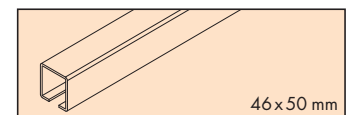

**Decken-Muffe inkl. Arretierschraube, Stahl verzinkt (alle 500 mm)**

Ceiling suspension bracket incl. locking bolt, zinc-plated steel (every 500 mm)  
Fixation de plafond vis d'arrêt incluse, en acier zingué (tout les 500 mm)

059.3002.171

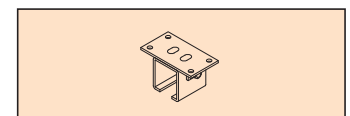

**Wand-Muffe inkl. Arretierschraube, Stahl verzinkt (alle 500 mm)**

Wall suspension bracket incl. locking bolt, zinc-plated steel (every 500 mm)  
Fixation murale vis d'arrêt incluse, en acier zingué (tout les 500 mm)

059.3003.171

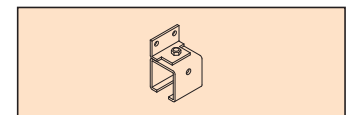

**Verbindungs-Muffe inkl. 2 Arretierschrauben, Stahl verzinkt**

Connecting sleeve incl. 2 locking bolts, zinc-coated steel  
Embout de raccord 2 vis d'arrêt incluse, en acier galvanisé

059.3001.171

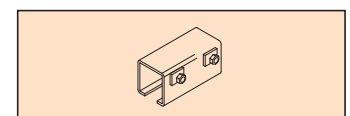

**Sonderzubehör / Special accessories / Accessoires spéciaux:** ☐ 29

**Einzelteile / Components / Pièces détachées:** ☐ 29

## EKU-PORTA 300 H

**Schienen-Verbindungs-U, Stahl verzinkt, gelocht**

Track connecting U-piece, zinc-plated steel, pre-drilled

Raccord en U pour rails, en acier zingué, perforé

Gr./Size

Art. No.

058.3004.101

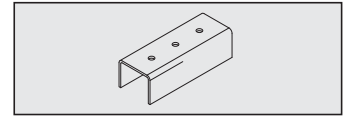
**Decken-Muffe inkl. Arretierschraube, Stahl verzinkt (alle 500 mm)**

Ceiling suspension bracket incl. locking bolt, zinc-plated steel (every 500 mm)

Fixation de plafond vis d'arrêt incluse, en acier zingué (tout les 500 mm)

058.3001.171

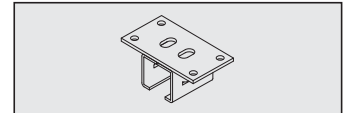
**Winkel-Set für Wandmontage, Stahl verzinkt**

Angle-bracket set for wall mounting, zinc-plated steel

Lot d'équerres de fixation murale, en acier zingué

10x

057.3005.172

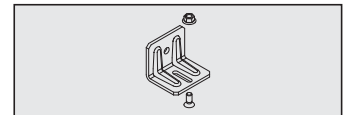
**Bodenführungsbolzen, zum Aufschrauben, zu 058.3010.101**

Bottom guide pin, screwed-on, for 058.3010.101

Boulon à visser, à visser, pour 058.3010.101

058.3015.171

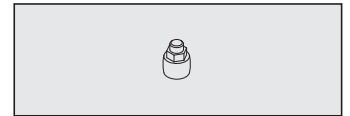
**T-Bodenführung, Stahl verzinkt**

T-floor-guide, zinc-plated steel

Guidage au sol en T, en acier zingué

058.3011.101

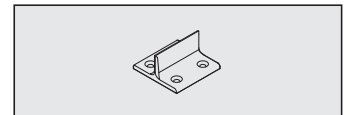
**Bodenführung mit Kunststoff-Rolle, Stahl verzinkt**

Bottom guide with plastic roller, zinc-plated steel

Galet de guidage au sol avec galet en plastique, en acier zingué

058.3012.171

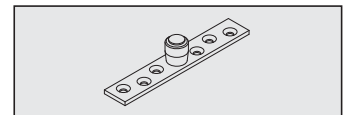
**U-Führungsschiene, Stahl verzinkt, gelocht**

U guide track, zinc-plated steel, pre-drilled

Rail de guidage en U, en acier zingué, perforé

6000 mm

058.3013.600

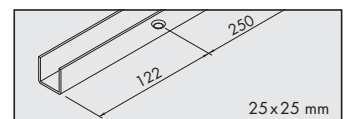

## EKU-PORTA 300 H

**Laufwerk, Kugellager, Rollen Kunststoff**

Runner, ball bearings, rollers plastic

Chariot, roulements à billes, galets en plastique

Art. No.

058.3005.171

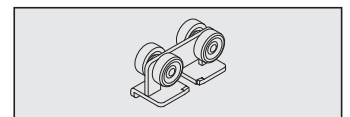
**Tragschraube M10 x 45, Stahl verzinkt**

Suspension bolt M10 x 45, zinc-plated steel

Vis porteuse M10 x 45, en acier zingué

058.3006.171

**Stopper, mit Gummipuffer, Stahl verzinkt**

Stopper, with rubber buffer, zinc-plated steel

Butée, avec butoir en caoutchouc, en acier zingué

058.3008.171

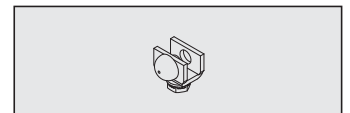
**Tragflansch, Stahl verzinkt**

Supporting bracket, zinc-plated steel

Platine porteuse, en acier zingué

058.3009.101

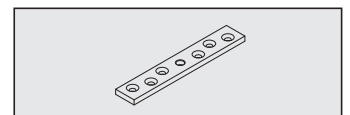
**Tragwinkel / Bodenführung, Stahl verzinkt**

Supporting angle bracket / Bottom guide, zinc-plated steel

Equerre porteuse / Guidage au sol, en acier zingué

058.3010.101

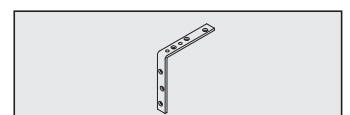

**EKU-PORTA 600 H**

**Laufwerk, Kugellager, Rollen Kunststoff**

Runner, ball bearings, rollers plastic  
Chariot, roulements à billes, galets en plastique

Gr./Size

Art. No.

059.3004.171

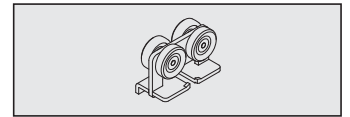

**Tragschraube M12 x 60, Stahl verzinkt**

Suspension bolt M12 x 60, zinc-plated steel  
Vis porteuse M12 x 60, en acier zingué

059.3005.171

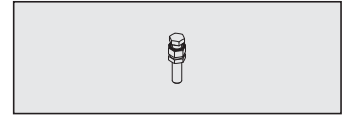

**Stopper, mit Gummipuffer, Stahl verzinkt**

Stopper, with rubber buffer, zinc-plated steel  
Butée, avec butoir en caoutchouc, en acier zingué

059.3009.171

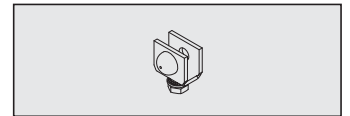

**Tragflansch, Stahl verzinkt**

Supporting bracket, zinc-plated steel  
Bride porteuse, en acier zingué

059.3007.101

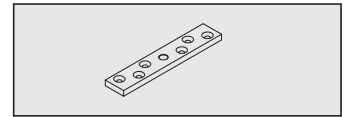

**Tragwinkel, Stahl verzinkt**

Supporting bracket, zinc-plated steel  
Platine porteuse, en acier zingué

059.3008.171

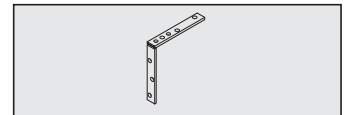

**T-Bodenführung, Stahl verzinkt**

T-floor-guide, zinc-plated steel  
Guidage au sol en T, en acier zingué

058.3011.101

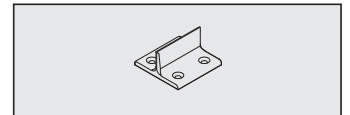

**Bodenführung mit Kunststoff-Rolle, Stahl verzinkt**

Bottom guide with plastic roller, zinc-plated steel  
Galet de guidage au sol avec galet en plastique, en acier zingué

058.3012.171

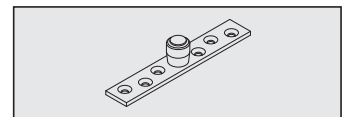

**U-Führungsschiene, Stahl verzinkt, gelocht**

U guide track, zinc-plated steel, pre-drilled  
Rail de guidage en U, en acier zingué, perforé

6000 mm

058.3013.600

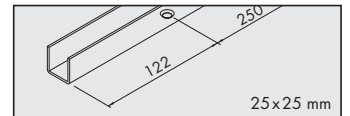

Getestet durch/Tested by/Testé par:

**Berner Fachhochschule  
Architektur, Bau und Holz  
CH-2504 Biel**

Bern University of Applied Sciences  
Architecture, Wood and Civil Engineering  
CH-2504 Biel

Haute école spécialisée bernoise  
Architecture, bois et génie civil  
CH-2504 Bienne



## QUALITY CERTIFICATE

EKU AG hereby certifies that the sliding door fittings of the product line **EKU-PORTA 100 Wood** comply with the requirements of DIN - EN 1527.

### Test Information

|                        |   |                   |
|------------------------|---|-------------------|
| Classification:        | DIN - EN 1527                               | - 6 2 0 - 0 - 1 3 |
| Door weight:           | 100 kg                                      |                   |
| Endurance test:        | 100'000 cycles                              |                   |
| Stop reliability:      | Complied with the requirements of DIN 68859 |                   |
| Retention reliability: | Complied with the requirements of DIN 68859 |                   |

### Additional Information

|                       |   |
|-----------------------|---|
| Ease of installation: | Requirements complied   |
| Tested by:            | Laboratory, School of Architecture, Civil and Wood Engineering, Biel   Test certificate No.: 7429-PZ-03 |
| Quality assurance:    | External and internal monitoring in accordance with ISO 9001:2000                                       |

**Heinz Schmidhauser**  
CEO/Managing Director

**Roland Stäheli**  
Quality Officer

**Walter Gämperle**  
Head of Development



Sirnach, 10. August 2006

EKU AG, Schiebelösungen, Wilerstrasse 90, 8370 Sirnach, Switzerland, Tel. +41 (0)71 96 96 100  
Fax +41 (0)71 96 96 110, office@eku.ch, www.eku.ch Certified ISO 9001 - Member of the HAWA Group

# TÜRGEWICHTE

Door weights | Poids de vantaux

**EKU PORTA**

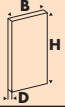
|  |        | <b>Spanplatte</b><br>Chipboard<br>Panneau d'aggloméré |
|---|--------|---|
| <b>D mm</b>   |        | <b>40 mm</b>  |
| B   | x H    |   |
| 900   | x 2000 | 40.5  |
| 1200  | x 2000 | 54.0  |
| 1500  | x 2000 | 67.5  |
| 900   | x 2200 | 44.5  |
| 1200  | x 2200 | 59.4  |
| 1500  | x 2200 | 74.2  |
| 2000  | x 2200 | 99.0  |
| 900   | x 2400 | 48.6  |
| 1200  | x 2400 | 64.8  |
| 1500  | x 2400 | 81.0  |
| 2000  | x 2400 | —   |
| 900   | x 2600 | 52.6  |
| 1200  | x 2600 | 70.2  |
| 1500  | x 2600 | 87.7  |
| <b>kg/m<sup>2</sup></b>   |        | <b>22.5</b>   |

|  |        | <b>MDF</b>   |
|---|--------|--------------|
| <b>D mm</b>   |        | <b>40 mm</b> |
| B   | x H    |              |
| 900   | x 2000 | 52.6         |
| 1200  | x 2000 | 70.1         |
| 1500  | x 2000 | 87.6         |
| 900   | x 2200 | 57.9         |
| 1200  | x 2200 | 77.1         |
| 1500  | x 2200 | 96.4         |
| 2000  | x 2200 | —            |
| 900   | x 2400 | 63.1         |
| 1200  | x 2400 | 84.1         |
| 1500  | x 2400 | —            |
| 2000  | x 2400 | —            |
| 900   | x 2600 | 68.4         |
| 1200  | x 2600 | 91.1         |
| 1500  | x 2600 | —            |
| <b>kg/m<sup>2</sup></b>   |        | <b>29.2</b>  |

## TECHNISCHE DATEN

Technical data | Caractéristiques techniques

- EKU-Produkte sind nach DIN-EN 1527, inklusive Herausfalltest DIN-EN 15706, getestet.**  
 EKU products have been tested in accordance with DIN-EN 1527, incl. fall-out test in accordance with DIN-EN 15706.  
 Les produits EKU sont testés conformément à la DIN-EN 1527, y compris le test de chute selon DIN-EN 15706.
- Längenmasse der Standardprofile aus dem EKU-Sortiment unterliegen der DIN ISO 2768-1 c (+/- 4 mm)**  
 The length dimensions of the standard profiles from the EKU range are subject to DIN ISO 2768-1 c (+/- 4 mm)  
 Les longueurs des profilés standard de la gamme EKU sont conformes aux exigences de la norme DIN ISO 2768-1 c (+/- 4 mm)
- Max. Türgewichte und Türmasse siehe jeweilige Katalogseiten. Das max. Türgewicht darf nicht überschritten werden!**  
 Max. door weights and door dimensions see respective catalogue pages. The maximum door weight may not be exceeded!  
 Max. poids et dimensions de vantaux voir pages correspondantes du catalogue. Le poids de porte maximal ne doit pas être dépassé!
- Die Produkte sind nicht für Aussenanwendungen geeignet.**  
 The products are inapplicable for outdoor applications/use.  
 Les produits sont inappropriés pour des applications extérieures/l'usage extérieur
- Technische Änderungen vorbehalten.**  
 Subject to technical modifications.  
 Sous réserve de modifications techniques.





06 2010



Vertrieb über den Fachhandel  
Available through specialised distributors  
Distribution par le commerce spécialisé

**Per Mausclick zur  
intelligenten Schiebe-Lösung:**

With a click of the mouse  
you arrive at the intelligent  
sliding solution:

Un clic de souris et vous  
arrivez à la solution intelligente  
pour portes coulissantes:

[www.eku.ch](http://www.eku.ch)



EKU AG, Schiebelösungen, Wilerstrasse 90, 8370 Sirnach, Switzerland, Tel.+41 (0)71 96 96 100  
Fax +41 (0)71 96 96 110, office@eku.ch, Certified ISO 9001 – Member of the HAWA Group